

THE INFORMATION CONTAINED IN THIS DRAWING IS THE SOLE PROPERTY OF L-COM, INC. ANY REPRODUCTION IN PART OR WHOLE WITHOUT THE WRITTEN PERMISSION OF L-COM, INC. IS PROHIBITED.

REVISION					
ZONE	REV	DESCRIPTION	DATE	CHANGED BY	APPROVED
	A	INITIAL RELEASE	09/22/2023	PSRINIVAS	DREBECK

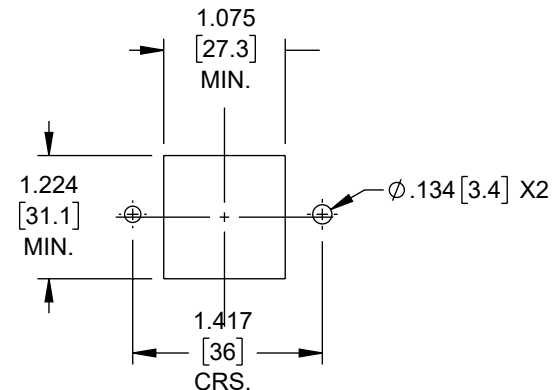
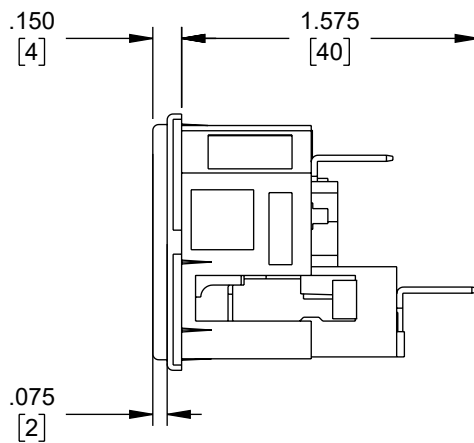
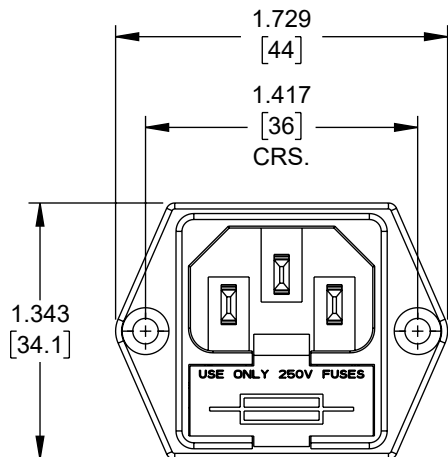

PANEL FIXING DETAILS

NOTES:-

- CONNECTOR TYPE: C14
- RATING: 10A, 250VAC
- FEATURES:  
AC PEM C14 PANEL FLANGE 6.3mm QUICK-CONNECT 2X FUSEHOLDERS
- PACKAGING NOTE:  
CONNECTOR SHALL BE INDIVIDUALLY PACKAGED, LABEL PER ILS-100
- ALL DIMENSIONS FOR REFERENCE ONLY

<p>UNLESS OTHERWISE SPECIFIED, DIMENSIONS ARE IN INCHES [mm]</p> <p>OVERALL CABLE LENGTH TOLERANCE:          ≤12 [305] = +1 [25] / -0          &gt;12 [305] ≤60 [1524] = +2 [51] / -0          &gt;60 [1524] ≤120 [3048] = +4 [102] / -0          &gt;120 [3048] ≤300 [7620] = +6 [152] / -0          &gt;300 [7620] = +5% / -0</p> <p>ALL OTHER DIMENSIONAL TOLERANCES:          .X = ± .2 [5]   FRACTIONS ± 1/32          .XX = ± .02 [5]   ANGLES ± 1°          .XXX = ± .005 [1.3]</p> <p>THIRD-ANGLE PROJECTION</p>	APPROVALS	DATE	<p>50 High Street, West Mill, North Andover, MA 01845 USA. Phone: 1.800.341.5266 1.978.682.6936</p>	
	DRAWN BY PSRINIVAS	09/22/2023		
	CHECKED BY DFRISIELLO	09/22/2023		
	APPROVED BY DREBECK	09/22/2023		
CONFIGURATION DETAILS OF UNDIMENSIONED FEATURES MAY VARY	<p>CATEGORY</p> <p><b>IEC CONNECTORS_PANEL FLANGE</b></p>		<p>PRODUCT DESCRIPTION</p> <p><b>AC PEM C14 PANEL FLANGE 6.3mm QUICK-CONNECT 2X FUSEHOLDERS</b></p>	
COLOR VARIATIONS MAY OCCUR	<p>SIZE</p> <p><b>A</b></p>	<p>CAGE CODE</p> <p><b>43321</b></p>		<p>ITEM NO.</p> <p><b>ACM-C4-GQ6F2-LC</b></p>
SCALE: NONE		CAD FILE: ACM-C4-GQ6F2-LC.SLDDRW		SHEET 1 OF 1