

THE INFORMATION CONTAINED IN THIS DRAWING IS THE SOLE PROPERTY OF L-COM, INC. ANY REPRODUCTION IN PART OR WHOLE WITHOUT THE WRITTEN PERMISSION OF L-COM, INC. IS PROHIBITED.

REVISION					
ZONE	REV	DESCRIPTION	DATE	CHANGED BY	APPROVED
	A	INITIAL RELEASE	09/01/2023	PSRINIVAS	DREBECK

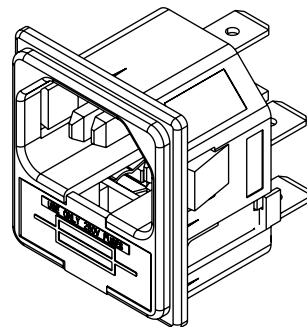
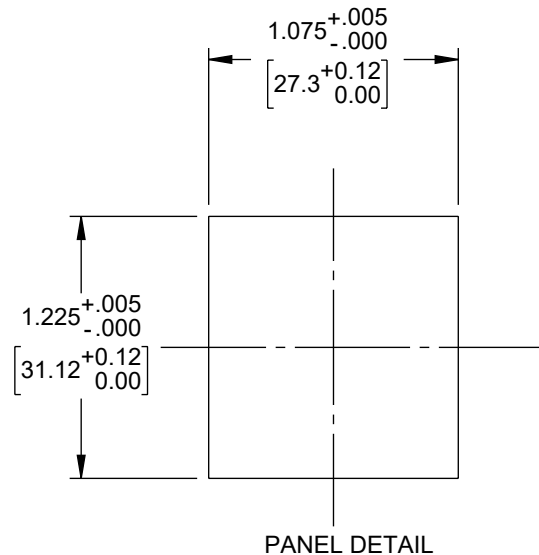
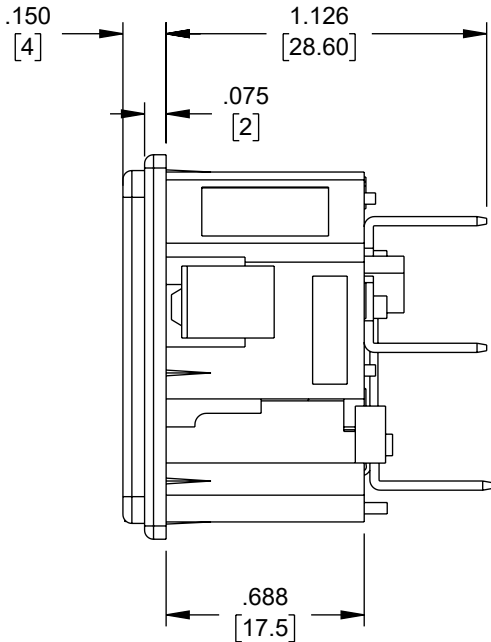
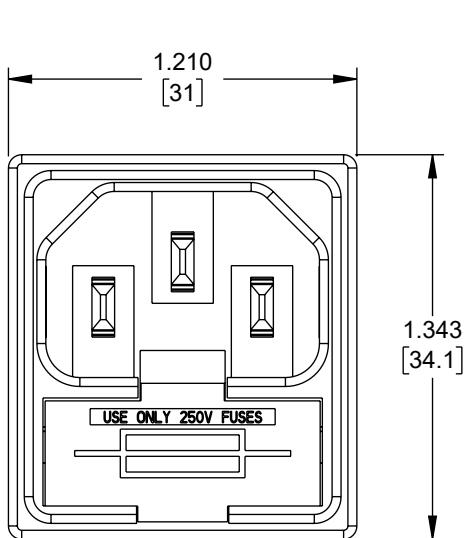

NOTES:-

- CONNECTOR TYPE: C14
- RATING: 10A, 250VAC
- FEATURES:
SNAPS INTO 1.5 mm PANEL
6.3 mm QUICK-CONNECT TERMINATIONS
SINGLE FUSEHOLDER
- CERTIFICATIONS: UL
- PACKAGING NOTE:
CONNECTOR SHALL BE INDIVIDUALLY PACKAGED, LABEL PER ILS-100
- ALL DIMENSIONS FOR REFERENCE ONLY

<p>UNLESS OTHERWISE SPECIFIED, DIMENSIONS ARE IN INCHES [mm]</p> <p>OVERALL CABLE LENGTH TOLERANCE: ≤12 [305] = +1 [25] / -0 >12 [305] ≤60 [1524] = +2 [51] / -0 >60 [1524] ≤120 [3048] = +4 [102] / -0 >120 [3048] ≤300 [7620] = +6 [152] / -0 >300 [7620] = +5% / -0</p> <p>ALL OTHER DIMENSIONAL TOLERANCES: .X = ± .2 [5] FRACTIONS ± 1/32 .XX = ± .02 [5] ANGLES ± 1° .XXX = ± .005 [13]</p> <p>THIRD-ANGLE PROJECTION</p>	APPROVALS	DATE	<p>50 High Street, West Mill, North Andover, MA 01845 USA. Phone: 1.800.341.5266 1.978.682.6936</p>							
	DRAWN BY PSRINIVAS	09/01/2023		<p>CATEGORY</p> <p>IEC CONNECTORS</p> <p>PRODUCT DESCRIPTION</p> <p>AC PEM C14 1.5mm PANEL SNAP-IN 6.3mm QUICK-CONNECT FUSEHOLDER</p>						
	CHECKED BY DFRISIELLO	09/01/2023								
	APPROVED BY DREBECK	09/01/2023								
CONFIGURATION DETAILS OF UNDIMENSIONED FEATURES MAY VARY	COLOR VARIATIONS MAY OCCUR	<table border="1"> <tr> <td>SIZE</td> <td>CAGE CODE</td> <td>ITEM NO.</td> <td>REV.</td> </tr> <tr> <td>A</td> <td>43321</td> <td>ACM-C4-N15Q6F-LC</td> <td>A</td> </tr> </table>	SIZE		CAGE CODE	ITEM NO.	REV.	A	43321	ACM-C4-N15Q6F-LC
SIZE	CAGE CODE	ITEM NO.	REV.							
A	43321	ACM-C4-N15Q6F-LC	A							
SCALE: NONE		CAD FILE: ACM-C4-N15Q6F-LC.SLDDRW	SHEET 1 OF 1							