

THE INFORMATION CONTAINED IN THIS DRAWING IS THE SOLE PROPERTY OF L-COM, INC. ANY REPRODUCTION IN PART OR WHOLE WITHOUT THE WRITTEN PERMISSION OF L-COM, INC. IS PROHIBITED.

REVISIONS			
REV	DESCRIPTION	DATE	APPROVED
A	INITIAL RELEASE	11/27/2013	B.ZHANG

PART NUMBER	LENGTH	
	FEET	METERS
CSMN459-2MM-1	1.0	0.31
CSMN459-2MM-2.5	2.5	0.76
CSMN459-2MM-5	5.0	1.52
CSMN459-2MM-10	10.0	3.05
CSMN459-2MM-15	15.0	4.57
CSMN459-2MM-25	25.0	7.62

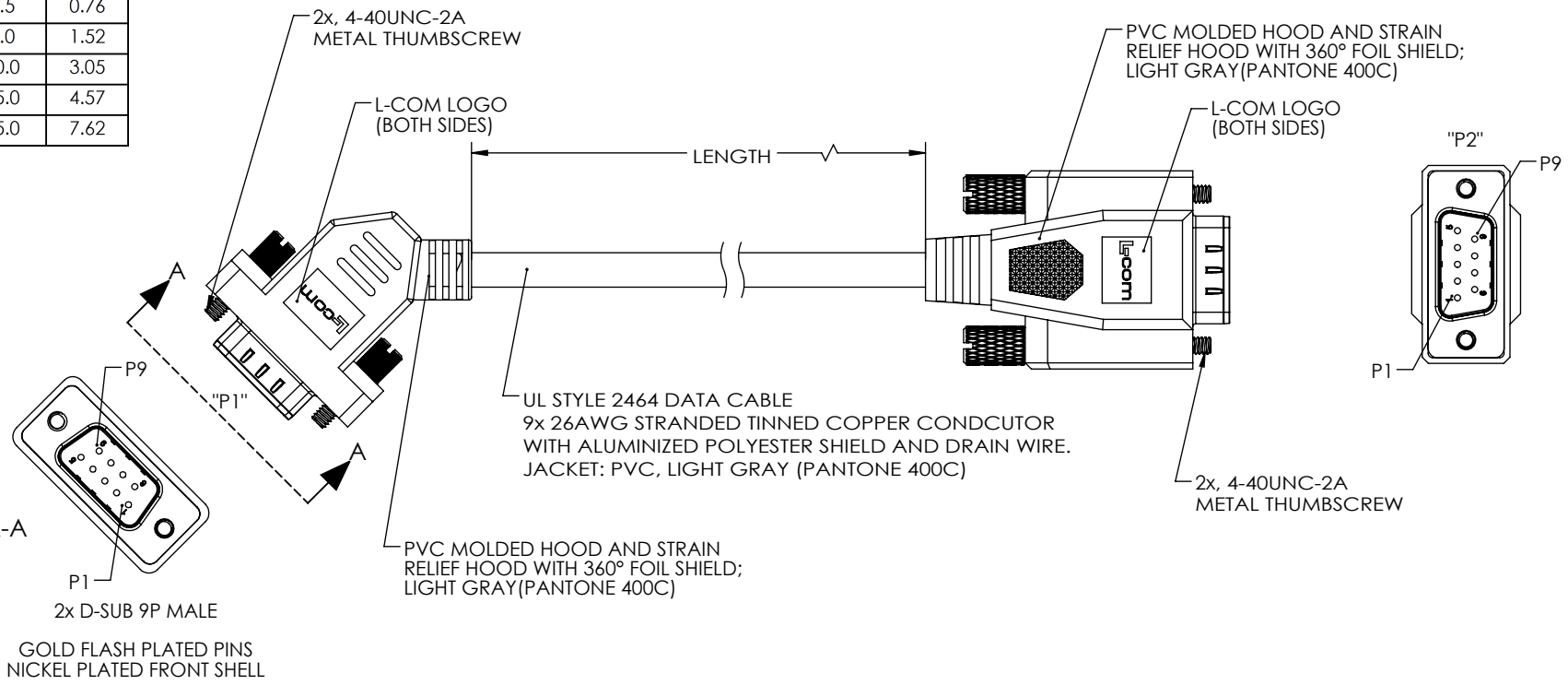

WIRING MAP		
"P1"	WIRE COLOR	"P2"
1	BLACK	1
2	GRAY	2
3	RED	3
4	GREEN	4
5	BROWN	5
6	BLUE	6
7	ORANGE	7
8	YELLOW	8
9	PURPLE	9
SHELL	DRAIN WIRE	SHELL

NOTES:

1. CABLE ASSEMBLY SHALL BE TESTED FOR CONTINUITY.
2. CABLE ASSEMBLY SHALL BE INDIVIDUALLY PACKAGED IN ACCORDANCE WITH L-COM PACKAGING SPEC. PS-0031.

REGULATORY COMPLIANCE:
CE2011/65/EU(RoHS DIRECTIVE)

UNLESS OTHERWISE SPECIFIED, DIMENSIONS ARE IN INCHES [mm] OVERALL CABLE LENGTH TOLERANCE: ≤ 12 [305] = +1 [25] / -0 >12 [305] ≤ 60 [1524] = +2 [51] / -0 >60 [1524] ≤ 120 [3048] = +4 [102] / -0 >120 [3048] ≤ 300 [7620] = +6 [152] / -0 >300 [7620] = +3% / -0% ALL OTHER DIMENSIONAL TOLERANCES: .X = ±.2 .XX = ±.02 .XXX = ±.005	APPROVALS DRAWN BY B.ZHANG CHECKED BY F.MAO APPROVED BY T.LU	DATE 08/25/2013 11/27/2013 11/27/2013	45 BEECHWOOD DRIVE NORTH ANDOVER, MA 01845	
	CONFIGURATION DETAILS OF UNDIMENSIONED FEATURES MAY VARY			CATEGORY D-SUBMINIATURE
	PROJECTION 	COLOR VARIATIONS MAY OCCUR	SIZE A	FSCM NO. 43321 DWG. NO. CSMN459-2MM REV. A
	CSMN-FS01		SCALE: NONE	CAD FILE: CSMN459-2MM.SLDDRW SHEET 1 OF 1