

THE INFORMATION CONTAINED IN THIS DRAWING IS THE SOLE PROPERTY OF L-COM, INC. ANY REPRODUCTION IN PART OR WHOLE WITHOUT THE WRITTEN PERMISSION OF L-COM, INC. IS PROHIBITED.

REVISION					
ZONE	REV	DESCRIPTION	DATE	CHANGED BY	APPROVED
	A	INITIAL RELEASE	04/18/2023	HBAKKE	PHOSPODAR

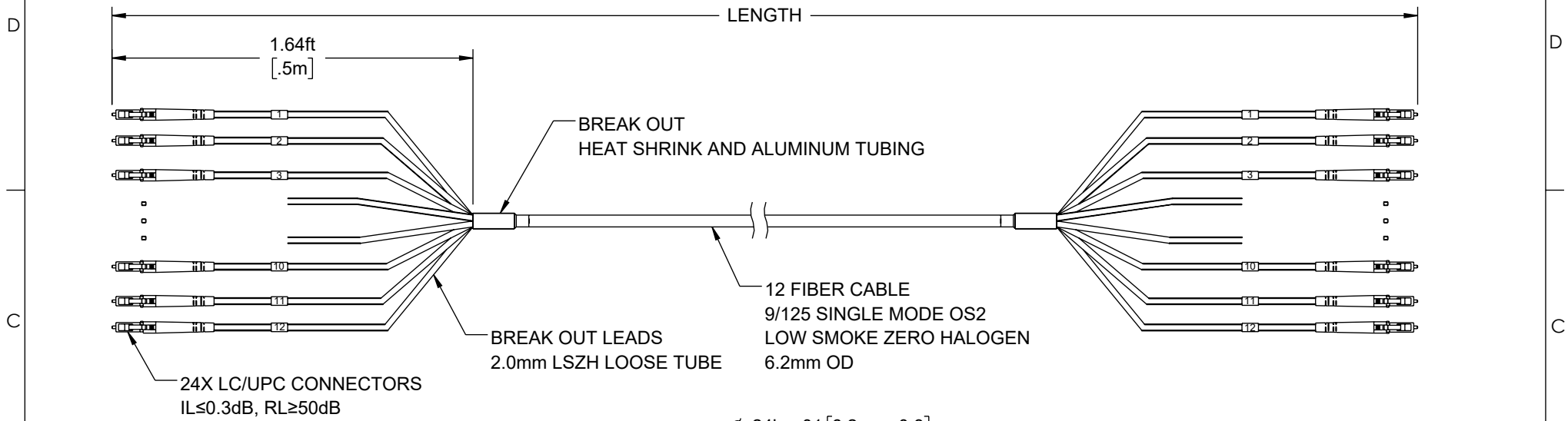

24X LC/UPC CONNECTORS
IL≤0.3dB, RL≥50dB

Ø .24in±.01 [6.2mm±0.3]

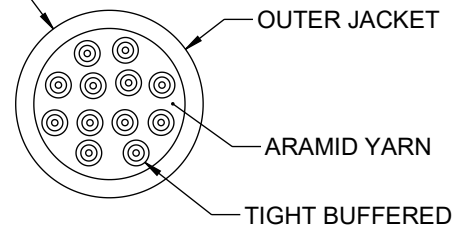

CABLE TECHNICAL PARAMETERS		
FIBER COUNT		12
FIBER TYPE		SINGLE MODE OS2
CORE DIAMETER (µm)		9
CLADDING DIAMETER (µm)		125
CABLE	OD in[mm]	.24 [6.2]
	MATERIAL	LSZH
BUFFER	OD in[mm]	.03 [.85]
	MATERIAL	LSZH
MAX. TENSILE STRENGTH (N)	SHORT TERM	480
	LONG TERM	240
MIN. BENDING RADIUS	DYNAMIC in[mm]	.79 [20.0]
	STATIC in[mm]	.39 [10.0]
MAX. CRUSH RESISTANCE (N/100mm)	SHORT TERM	1000
	LONG TERM	300
COLOR		BLACK
STRENGTH MEMBERS		ARAMID YARN

ITEM NUMBER	LENGTH	
	METERS	FEET
FCA-12S2LCULCUD2-3	3.0	9.84
FCA-12S2LCULCUD2-5	5.0	16.40
FCA-12S2LCULCUD2-10	10.0	32.81
FCA-12S2LCULCUD2-15	15.0	49.21
FCA-12S2LCULCUD2-20	20.0	65.62

NOTES:

- ALL CONNECTORS ACCOMPANIED WITH A DUST CAP INSTALLED (NOT SHOWN).

REGULATORY COMPLIANCE:
EU RoHS DIRECTIVE (MOST RECENT RELEASED VERSION)

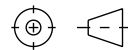
UNLESS OTHERWISE SPECIFIED, DIMENSIONS ARE IN INCHES [mm]	APPROVALS	DATE	 an INFINITI® brand	50 High Street, West Mill, North Andover, MA 01845 USA. Phone: 1.800.341.5266 1.978.682.6936		
	OVERALL CABLE LENGTH TOLERANCE: ≤12 [305] = +1 [25] / -0 >12 [305] ≤60 [1524] = +2 [51] / -0 >60 [1524] ≤120 [3048] = +4 [102] / -0 >120 [3048] ≤300 [7620] = +6 [152] / -0 >300 [7620] = +5% / -0	DRAWN BY HBAKKE			04/18/2023	
ALL OTHER DIMENSIONAL TOLERANCES: .X = ± .2 [5] FRACTIONS ± 1/32 .XX = ± .02 [5] ANGLES ± 1° .XXX = ± .005 [13]	CHECKED BY DMAY	04/18/2023	CATEGORY FIBER OPTICS			
	APPROVED BY REVANGELIS	04/18/2023	PRODUCT DESCRIPTION 12 Strand LC/UPC to LC/UPC 9/125 SM OS2, 6.2mm Distribution Cable, 2.0mm Breakout 0.5M, LSZH			
THIRD-ANGLE PROJECTION 	CONFIGURATION DETAILS OF UNDIMENSIONED FEATURES MAY VARY	COLOR VARIATIONS MAY OCCUR	SIZE A	CAGE CODE 43321	ITEM NO. FCA-12S2LCULCUD2	REV. A
			SCALE: NONE	CAD FILE: FCA-12S2LCULCUD2.SLDDRW	SHEET 1 OF 1	