

THE INFORMATION CONTAINED IN THIS DRAWING IS THE SOLE PROPERTY OF L-COM, INC. ANY REPRODUCTION IN PART OR WHOLE WITHOUT THE WRITTEN PERMISSION OF L-COM, INC. IS PROHIBITED.

REVISIONS			
REV	DESCRIPTION	DATE	APPROVED
A	INITIAL RELEASE	04/25/2022	PHOSPODAR

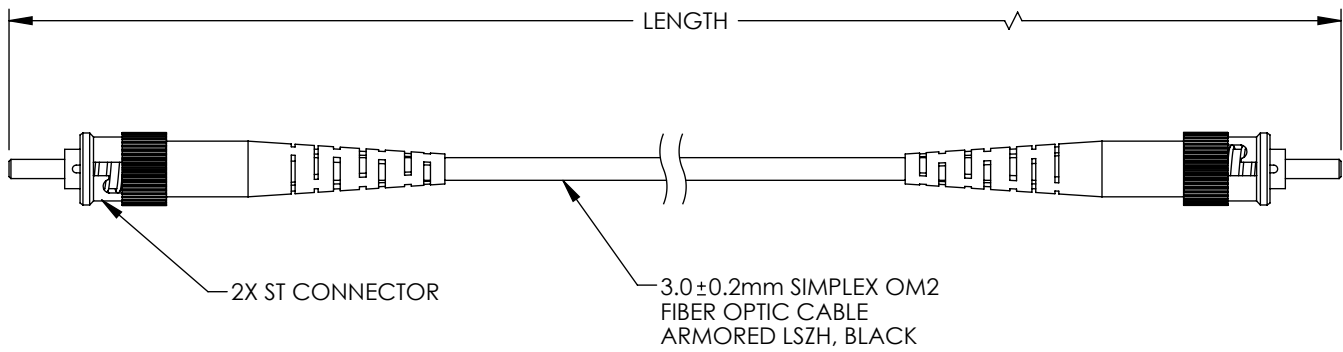

PART NUMBER	LENGTH METER [FEET]
FCA-M2ST-ST-02	2.0 [6.56]
FCA-M2ST-ST-05	5.0 [16.40]
FCA-M2ST-ST-10	10.0 [32.81]
FCA-M2ST-ST-15	15.0 [49.21]

NOTES:

- ST CONNECTOR ASSEMBLY POLISH TYPE: UPC.
- ALL CONNECTORS ACCOMPANIED WITH A DUST CAP INSTALLED (NOT SHOWN).
- CABLE ASSEMBLY SHALL BE INDIVIDUALLY PACKAGED.

REGULATORY COMPLIANCE:
EU ROHS DIRECTIVE (MOST RECENT RELEASED VERSION).

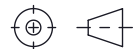
UNLESS OTHERWISE SPECIFIED, DIMENSIONS ARE IN INCHES [mm] OVERALL CABLE LENGTH TOLERANCE: ≤12 [305] = +1 [25] / -0 >12 [305] ≤60 [1524] = +2 [51] / -0 >60 [1524] ≤120 [3048] = +4 [102] / -0 >120 [3048] ≤300 [7620] = +6 [152] / -0 >300 [7620] = +5% / -0 ALL OTHER DIMENSIONAL TOLERANCES: .X = ± .2 [5] FRACTIONS ± 1/32 .XX = ± .02 [5] ANGLES ± 1° .XXX = ± .005 [1.3]	APPROVALS DRAWN BY K.GLEBOVA CHECKED BY P.HOSPODAR APPROVED BY P.HOSPODAR	DATE 04/18/2022 04/25/2022 04/25/2022	 an INFINITO brand 50 High Street, West Mill, North Andover, MA 01845 USA. Phone: 1.800.341.5266 1.978.682.6936	
	THIRD-ANGLE PROJECTION 	CONFIGURATION DETAILS OF UNDIMENSIONED FEATURES MAY VARY COLOR VARIATIONS MAY OCCUR		CATEGORY FIBER OPTICS
SIZE A		CAGE CODE 43321	ITEM NO. FCA-M2ST-ST-STS	REV. A
SCALE: NONE		CAD FILE: FCA-M2ST-ST-STS.SLDDRW		SHEET 1 OF 1