

THE INFORMATION CONTAINED IN THIS DRAWING IS THE SOLE PROPERTY OF L-COM, INC. ANY REPRODUCTION IN PART OR WHOLE WITHOUT THE WRITTEN PERMISSION OF L-COM, INC. IS PROHIBITED.

REVISION					
ZONE	REV	DESCRIPTION	DATE	CHANGED BY	APPROVED
	A	INITIAL RELEASE	09/25/2023	LNAGARAJ	PHOSPODAR

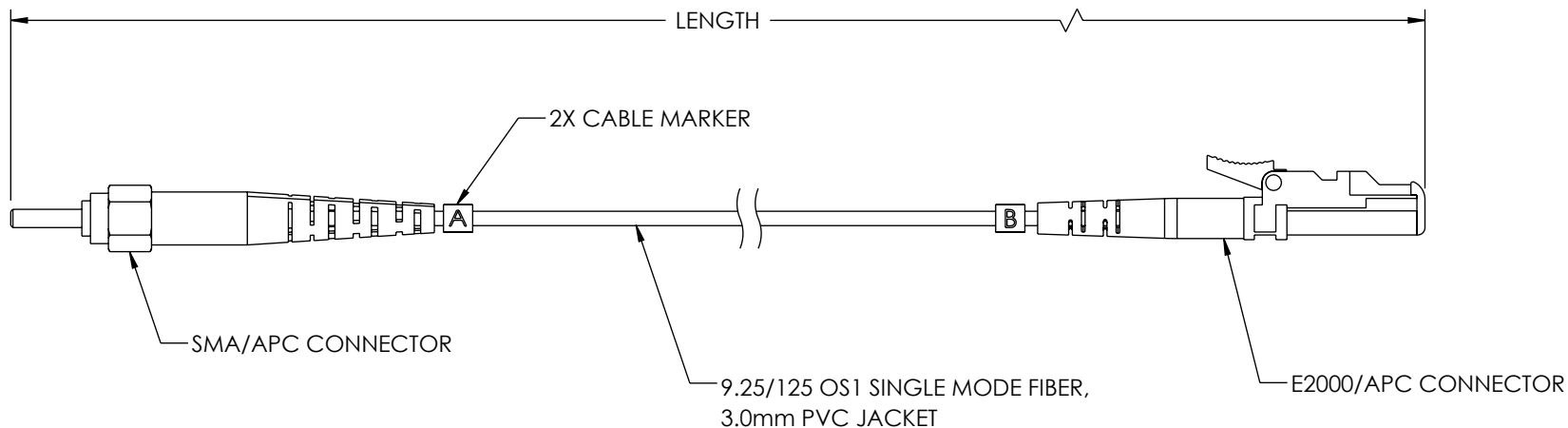

SPECIFICATIONS:	
FIBER TYPE/MODE	OS1 9.25/125um
OPERATING WAVELENGTH	1310nm, 1550nm
INSERTION LOSS	≤0.3dB
RETURN LOSS	≥60dB
MINIMUM BEND RADIUS (FIBER CORE)	10mm
MINIMUM BEND RADIUS (FIBER CABLE)	10/5D (DYNAMIC/STATIC)
OPERATING TEMPERATURE	-40°C~+60°C
STORAGE TEMPERATURE	-45°C~+85°C
COMPLIANT STANDARDS	CE, RoHS, REACH and IEC

PART NUMBER	LENGTH METER [FEET]
FCA-SMAE2A-SPS1V-01	1.0 [3.28]
FCA-SMAE2A-SPS1V-05	5.0 [16.40]

NOTES:

- ALL CONNECTORS ACCOMPANIED WITH A DUST CAP INSTALLED (NOT SHOWN).
- CABLE ASSEMBLY SHALL BE INDIVIDUALLY PACKAGED.

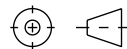
UNLESS OTHERWISE SPECIFIED, DIMENSIONS ARE IN INCHES [mm]	APPROVALS	DATE	 50 High Street, West Mill, North Andover, MA 01845 USA. Phone: 1.800.341.5266 1.978.682.6936		
	OVERALL CABLE LENGTH TOLERANCE: ≤12 [305] = +1 [25] / -0 >12 [305] ≤60 [1524] = +2 [51] / -0 >60 [1524] ≤120 [3048] = +4 [102] / -0 >120 [3048] ≤300 [7620] = +6 [152] / -0 >300 [7620] = +5% / -0	DRAWN BY LNAGARAJ 09/25/2023		CHECKED BY TCAHALANE 09/28/2023	
ALL OTHER DIMENSIONAL TOLERANCES: .X = ± .2 [5] FRACTIONS ± 1/32 .XX = ± .02 [5] ANGLES ± 1° .XXX = ± .005 [13]	APPROVED BY PHOSPODAR 09/29/2023	CATEGORY FIBER OPTICS	PRODUCT DESCRIPTION FIBER OPTIC PATCH CABLE SMA/APC TO E2000/APC SIMPLEX 9.25/125 SINGLE MODE PVC		
	THIRD-ANGLE PROJECTION 	CONFIGURATION DETAILS OF UNDIMENSIONED FEATURES MAY VARY		SIZE A	CAGE CODE 43321
COLOR VARIATIONS MAY OCCUR		SCALE: NONE	CAD FILE: FCA-SMAE2A-SPS1V.SLDDRW	SHEET 1 OF 1	