

THE INFORMATION CONTAINED IN THIS DRAWING IS THE SOLE PROPERTY OF L-COM, INC. ANY REPRODUCTION IN PART OR WHOLE WITHOUT THE WRITTEN PERMISSION OF L-COM, INC. IS PROHIBITED.

REVISIONS			
REV	DESCRIPTION	DATE	APPROVED
E	ECN 5484: UPDATED DRAWING TO MATCH SUPPLIER PART	5/5/11	D. CASTRO
F	ECN 5538: CH'G HOLES TO Ø.087 - Ø.098 FROM Ø.098	6/3/11	D. CASTRO
G	ECN 8898: UPDATE SLEEVE MAT'L, MODIFY C'BORE SCREW HOLES	8/29/2017	R. CLARK

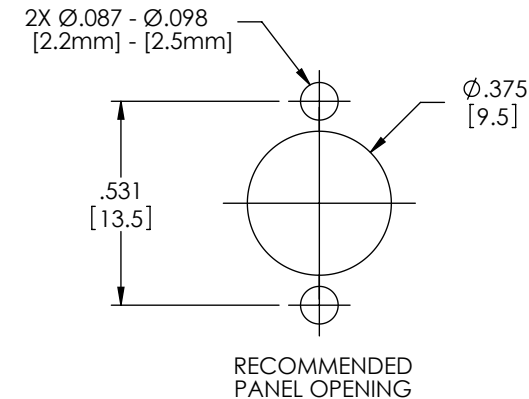
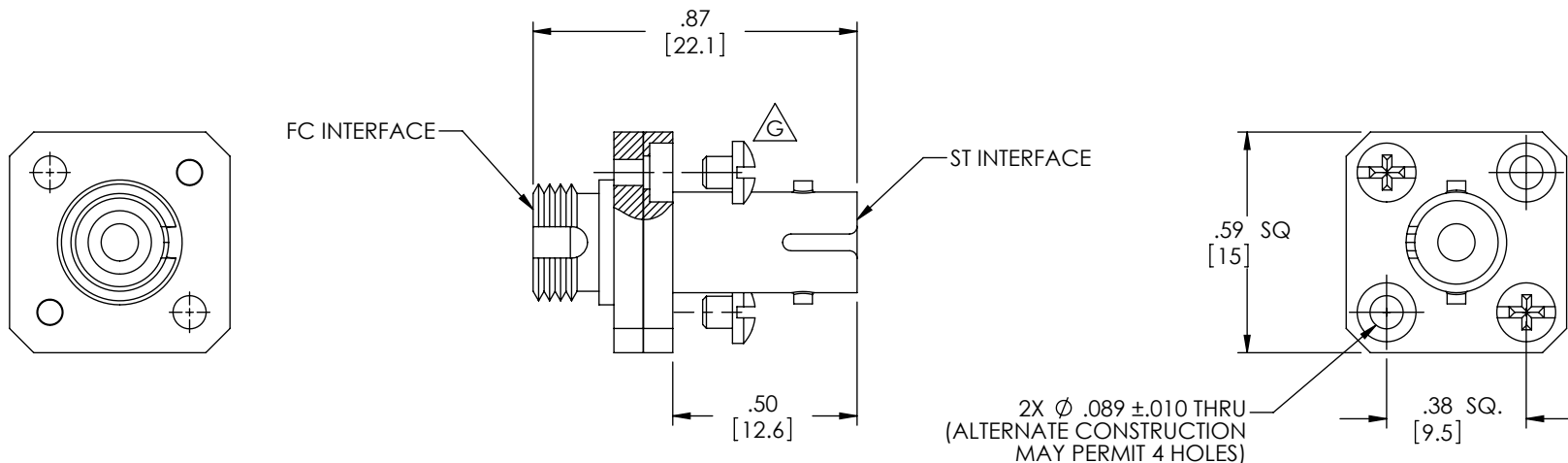

**NOTES:**

ALL DIMENSIONS ARE FOR REFERENCE ONLY

**MATERIAL:**

FC ADAPTOR BODY SIMPLEX: COPPER, NICKEL.  
 ST ADAPTOR BODY SIMPLEX: COPPER, NICKEL.  
 SCREWS: COPPER, NICKEL.  
 SLEEVE: ZrO2/ PHOSPHOR BRONZE.  
 FC ADAPTOR CAP: PVC.  
 ST ADAPTOR CAP: PVC.

**MISCELLANEOUS:**

INSERTION LOSS: .20dB MAX.  
 DURABILITY: (500 MATINGS) .15 dB MAX.  
 RETENTION FORCE: 200~600 GRAMS.  
 OPERATING TEMPERATURE: -40°C ~ +80°C.  
 COMPONENT SHALL BE INDIVIDUALLY PACKAGED IN ACCORDANCE WITH L-COM SPEC. PS-0031.

**REGULATORY COMPLIANCE:**  
 CE2011/65/EU (RoHS DIRECTIVE)

UNLESS OTHERWISE SPECIFIED, DIMENSIONS ARE IN INCHES [mm] OVERALL CABLE LENGTH TOLERANCE: ≤12 [305] = +1 [25] / -0 >12 [305] ≤60 [1524] = +2 [51] / -0 >60 [1524] ≤120 [3048] = +4 [102] / -0 >120 [3048] ≤300 [7620] = +6 [152] / -0 >300 [7620] = +5% / -0%	APPROVALS	DATE			50 HIGH STREET NORTH ANDOVER, MA 01845
	DRAWN BY D.PARHAM	10/26/2000			CATEGORY
ALL OTHER DIMENSIONAL TOLERANCES: .X = ± .2 [5.08] .XX = ± .02 [5.1] .XXX = ±.005 [1.3]	CHECKED BY T.CLARK	10/26/2000	PRODUCT DESCRIPTION <b>ADPTR,SQR/MTL ST-FC SMLPX BRNZ</b>		
	APPROVED BY R.CARRICK	10/26/2000			
PROJECTION 	COLOR VARIATIONS MAY OCCUR		SCALE: NONE	CAD FILE: FOA-301.SLDDRW	SHEET 1 OF 1