

8 7 6 5 4 3 2 1

THE INFORMATION CONTAINED IN THIS DRAWING IS THE SOLE PROPERTY OF L-COM, INC. ANY REPRODUCTION IN PART OR WHOLE WITHOUT THE WRITTEN PERMISSION OF L-COM, INC. IS PROHIBITED.

REVISIONS			
REV	DESCRIPTION	DATE	APPROVED
A	INITIAL RELEASE	02/25/2020	PHOSPODAR

FIBER TYPE	MULTIMODE, OM1, PLENUM
CORE DIAMETER	62.5 μm
CLADDING DIAMETER	125 μm
PRIMARY COATING DIA. (UV CURED ACRYLATE)	245 μm
SECONDARY BUFFER DIA. (HARD ELASTOMERIC)	900 μm
NUMERICAL APERTURE	0.275
PROOF TEST LEVEL	100 kpsi

WAVELENGTH:	850 nm	1310 nm
GIGABYTE ETHERNET DISTANCE	300 m	600 m
10-GIGABYTE ETHERNET DISTANC	33 m	300 m
MAXIMUM ATTENUATION	3.5 dB/km	1.5 dB/km
MINIMUM LASER BANDWIDTH	220 MHz-km	500 MHz-km
MINIMUM LED BANDWIDTH	200 MHz-km	500 MHz-km

CABLE WEIGHT	18 kg/km (12 lbs/1000 ft)
CABLE DIAMETER	2.9 x 5.8 mm (0.11 x 0.23 in)

INSTALLATION:	
MAX TENSILE LOAD	1000 N (220 lbs)
MIN BEND RADIUS	5.0 cm (2.0 in)

OPERATING:	
MAX TENSILE LOAD	500 N (110 lbs)
MIN BEND RADIUS	3.0 cm (1.2 in)

IMPACT RESISTANCE	200 IMPACTS
CRUSH RESISTANCE	500 N/cm

OPERATING TEMPERATURE	0°C TO +70°C
STORAGE TEMPERATURE	-40°C TO +85°C
INSTALLATION TEMPERATURE	0°C TO +60°C (actual temp. of cable)
FLAME RETARDANCY	OFNP

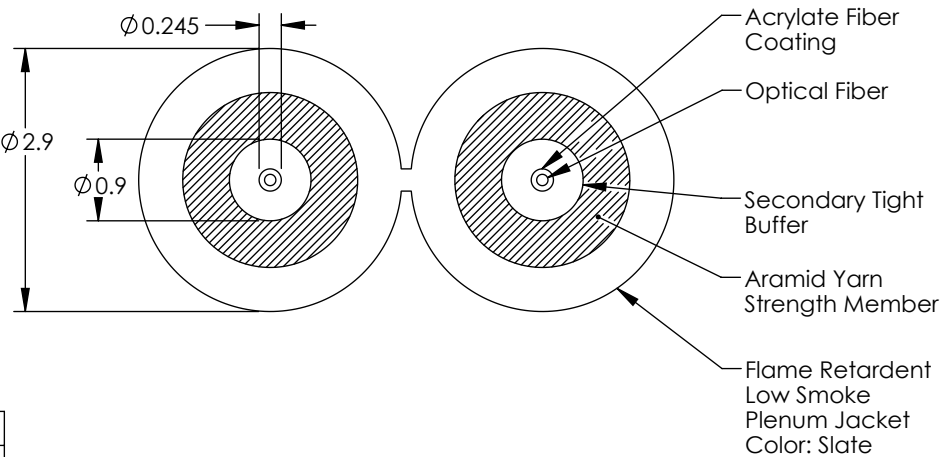
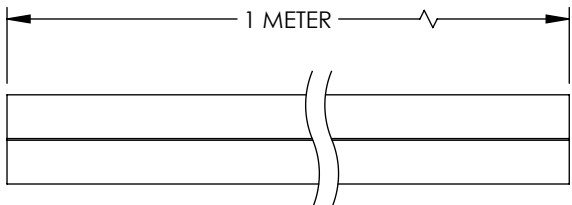

ALL DIMENSIONS IN mm, DRAWING NOT TO SCALE

NOTES:

1. CABLE SHALL BE INDIVIDUALLY PACKAGED IN ACCORDANCE WITH L-COM SPECIFICATION PS-0031.

UNLESS OTHERWISE SPECIFIED, DIMENSIONS ARE IN INCHES (mm)	APPROVALS	DATE	 50 High Street, West Mill, North Andover, MA 01845 USA. Phone: 1.800.341.5266 1.978.682.6936
	OVERALL CABLE LENGTH TOLERANCE: ≤12 [305] = +1 [25] / -0 >12 [305] ≤60 [1524] = +2 [51] / -0 >60 [1524] ≤120 [3048] = +4 [102] / -0 >120 [3048] ≤300 [7620] = +6 [152] / -0 >300 [7620] = +5% / -0	DRAWN BY DZINN	
ALL OTHER DIMENSIONAL TOLERANCES: .X = ± .2 [5] .XX = ± .02 [.5] .XXX = ± .005 [.13] FRACTIONS ± 1/32 ANGLES ± 1°	CHECKED BY DFRISIELLO	02/25/2020	CATEGORY <b>FIBER OPTIC</b>
	APPROVED BY PHOSPODAR	02/25/2020	
THIRD-ANGLE PROJECTION 	CONFIGURATION DETAILS OF UNDIMENSIONED FEATURES MAY VARY	COLOR VARIATIONS MAY OCCUR	SIZE <b>A</b>
		CAGE CODE <b>43321</b>	ITEM NO. <b>FOB30OM1PSZ-M</b>
		SCALE: NONE	CAD FILE: FOB30OM1PSZ-M.SLDDRW
		SHEET 1 OF 1	