

THE INFORMATION CONTAINED IN THIS DRAWING IS THE SOLE PROPERTY OF L-COM, INC. ANY REPRODUCTION IN PART OR WHOLE WITHOUT THE WRITTEN PERMISSION OF L-COM, INC. IS PROHIBITED.

| REVISION |     |                 |            |            |           |
|----------|-----|-----------------|------------|------------|-----------|
| ZONE     | REV | DESCRIPTION     | DATE       | CHANGED BY | APPROVED  |
|          | A   | INITIAL RELEASE | 08/25/2023 | KGLEBOVA   | PHOSPODAR |

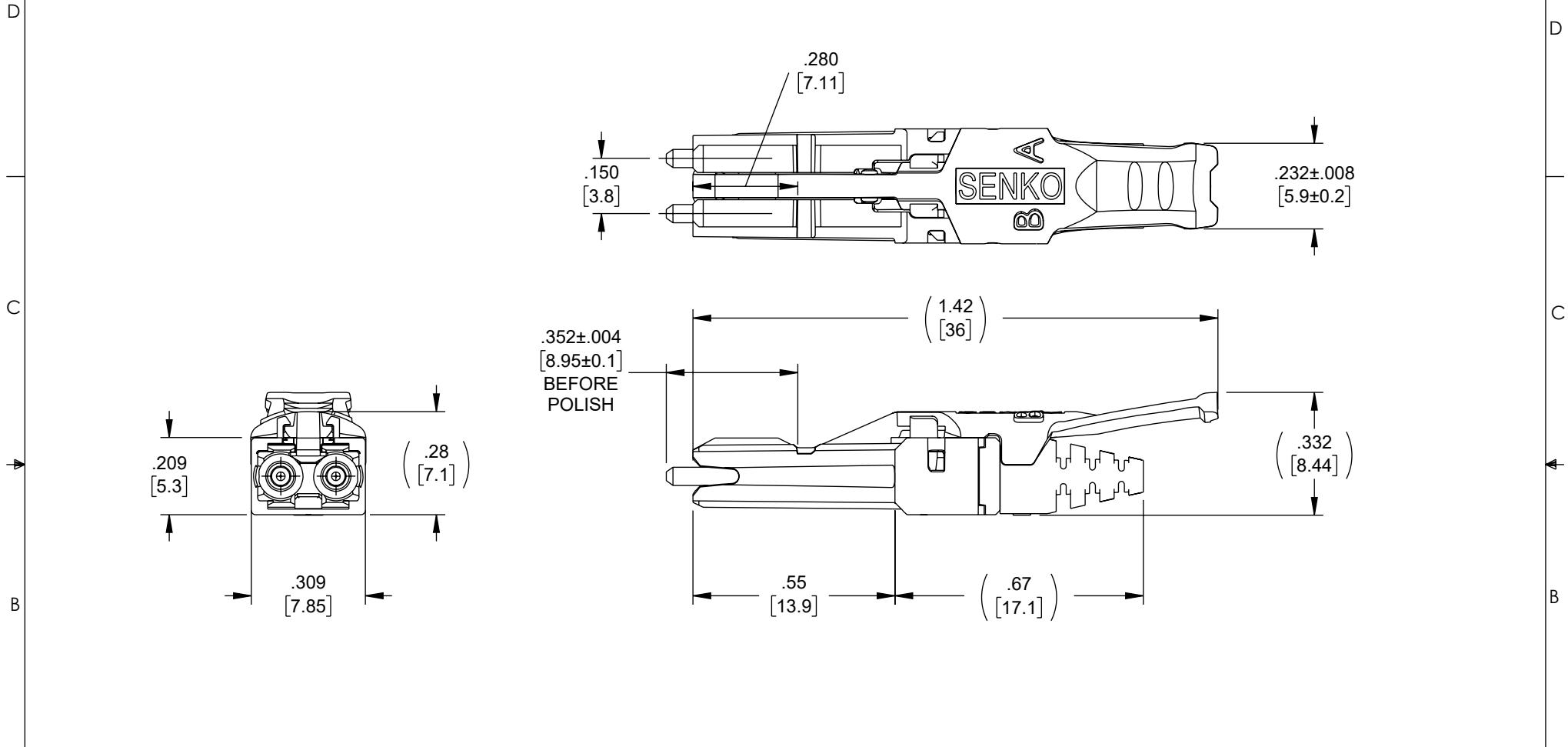

NOTES:

- CONNECTOR SUPPLIED WITH A DUST CAP INSTALLED WHICH IS NOT SHOWN.
- CONNECTOR COMES IN KIT OF SUB-COMPONENTS.
- CONNECTOR SHALL BE INDIVIDUALLY PACKAGED IAW L-COM SPECIFICATION PS-0031.

REGULATORY COMPLIANCE:  
EU ROHS DIRECTIVE (MOST RECENT RELEASED VERSION)

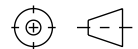
|   |   |   |   |                                   |                  |
|---|---|---|---|-----------------------------------|------------------|
| UNLESS OTHERWISE SPECIFIED,<br>DIMENSIONS ARE IN INCHES [mm]<br><br>OVERALL CABLE LENGTH TOLERANCE:<br>≤12 [305] = +1 [25] / -0<br>>12 [305] ≤60 [1524] = +2 [51] / -0<br>>60 [1524] ≤120 [3048] = +4 [102] / -0<br>>120 [3048] ≤300 [7620] = +6 [152] / -0<br>>300 [7620] = +5% / -0<br><br>ALL OTHER DIMENSIONAL TOLERANCES:<br>.X = ± .2 [5]   FRACTIONS ± 1/32<br>.XX = ± .02 [5]   ANGLES ± 1°<br>.XXX = ± .005 [13] | APPROVALS<br>DRAWN BY<br>KGLEBOVA<br>CHECKED BY<br>DMAY<br>APPROVED BY<br>PHOSPODAR | DATE<br>08/17/2023<br>08/17/2023<br>08/17/2023  |  50 High Street, West Mill,<br>North Andover, MA 01845 USA.<br>Phone: 1.800.341.5266<br>1.978.682.6936 |                                   |                  |
|   | CONFIGURATION DETAILS OF<br>UNDIMENSIONED FEATURES<br>MAY VARY                      |   |   | CATEGORY<br><b>FIBER OPTIC</b>    |                  |
| THIRD-ANGLE PROJECTION<br>   | COLOR VARIATIONS<br>MAY OCCUR   | PRODUCT DESCRIPTION<br>CS CONNECTOR (2F), MULTIMODE FIBER WITH UPC POLISH,<br>BTW BOOT AND 36MM TAB LENGTH IN WHITE | SCALE: NONE   CAD FILE: FOC-CSMU51-36W.SLDDRW   SHEET 1 OF 1  |                                   |                  |
|   |   | SIZE<br><b>A</b>  | CAGE CODE<br><b>43321</b>   | ITEM NO.<br><b>FOC-CSMU51-36W</b> | REV.<br><b>A</b> |