

THE INFORMATION CONTAINED IN THIS DRAWING IS THE SOLE PROPERTY OF L-COM, INC. ANY REPRODUCTION IN PART OR WHOLE WITHOUT THE WRITTEN PERMISSION OF L-COM, INC. IS PROHIBITED.

RoHS Compliant ✓

REVISIONS			
REV	DESCRIPTION	DATE	APPROVED
E	ECN 6839: REVISED NOTE 4, ADDED NOTE 5	5/15/13	D.FRISIELLO

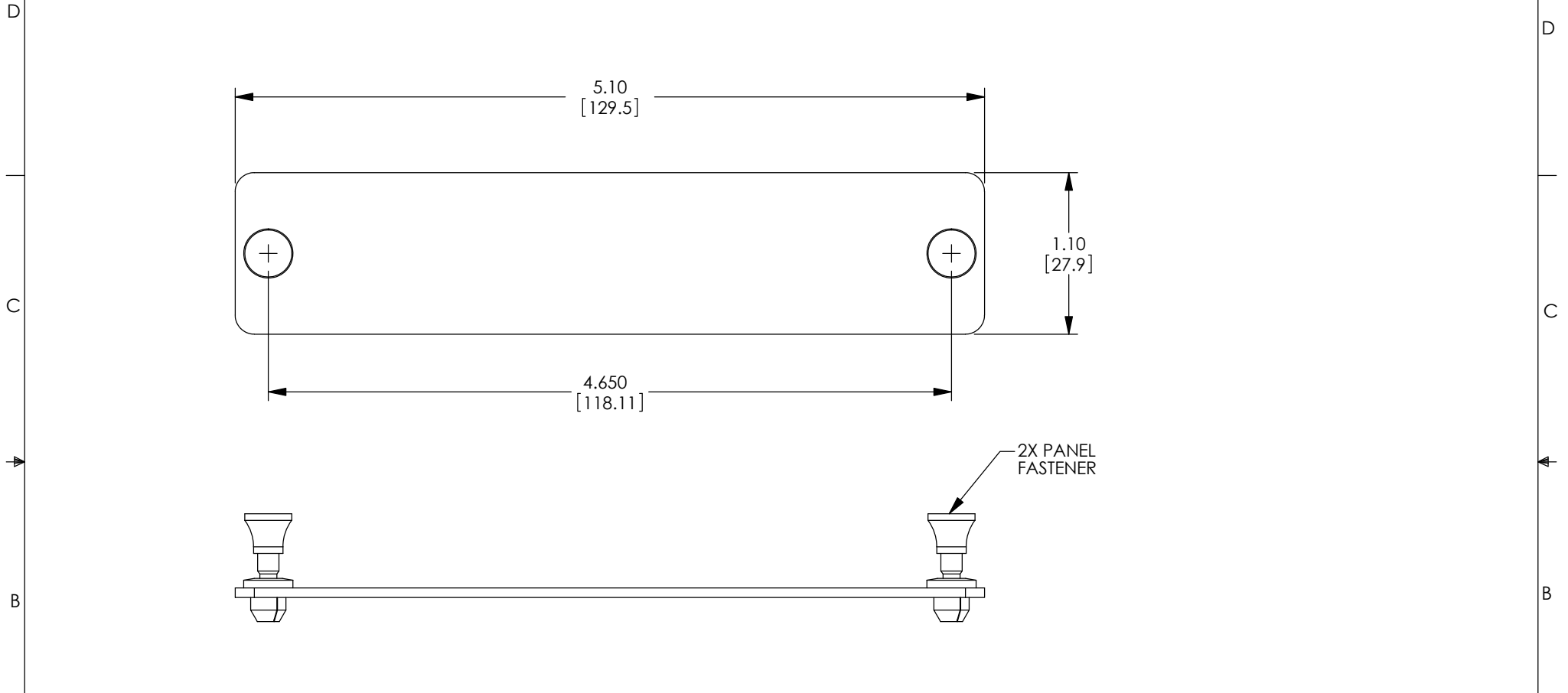

NOTES:

- PANEL MATERIAL: .06 THK COLD ROLLED STEEL.  
PANEL FASTENER: THERMOPLASTIC.
- FINISH: BLACK POWDER COAT.
- RECOMMENDED MOUNTING HOLE FOR MATING FASTENER,  $\varnothing .252 +.002/.000$
- COMPONENT SHALL BE INDIVIDUALLY PACKAGED IN A CLEAR BAG LABELED AS FOLLOWS:

FSP-BNK

- CENTER THE LABEL ON THE CLEAR BAG.

UNLESS OTHERWISE SPECIFIED, DIMENSIONS ARE IN INCHES [mm] OVERALL CABLE LENGTH TOLERANCE: $\leq 12$ [305] = +1 [25] / -0 $>12$ [305] $\leq 60$ [1524] = +2 [51] / -0 $>60$ [1524] $\leq 120$ [3048] = +4 [102] / -0 $>120$ [3048] $\leq 300$ [7620] = +6 [152] / -0 $>300$ [7620] = +3% / -0% ALL OTHER DIMENSIONAL TOLERANCES: .X = $\pm .2$ .XX = $\pm .02$ .XXX = $\pm .005$	APPROVALS DRAWN BY MCCORMICK CHECKED BY D.PARHAM APPROVED BY R.CARRICK	DATE 01/22/02 01/22/02 01/22/02	45 BEECHWOOD DRIVE NORTH ANDOVER, MA 01845	
	CONFIGURATION DETAILS OF UNDIMENSIONED FEATURES MAY VARY			CATEGORY <b>FIBER OPTIC SUB PANELS</b>
	PROJECTION 	COLOR VARIATIONS MAY OCCUR	SIZE <b>A</b>	FSCM NO. <b>43321</b>
	DWG. NO. <b>FSP-BNK</b>		SCALE: NONE	CAD FILE: FSP-BNK.SLDDRW
SHEET 1 OF 1			REV. <b>E</b>	