

THE INFORMATION CONTAINED IN THIS DRAWING IS THE SOLE PROPERTY OF L-COM, INC. ANY REPRODUCTION IN PART OR WHOLE WITHOUT THE WRITTEN PERMISSION OF L-COM, INC. IS PROHIBITED.

REVISIONS			
REV	DESCRIPTION	DATE	APPROVED
A	INITIAL RELEASE	3/17/11	D.GRIFFIN
-	-	-	-

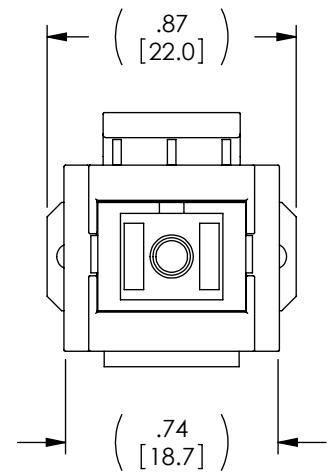
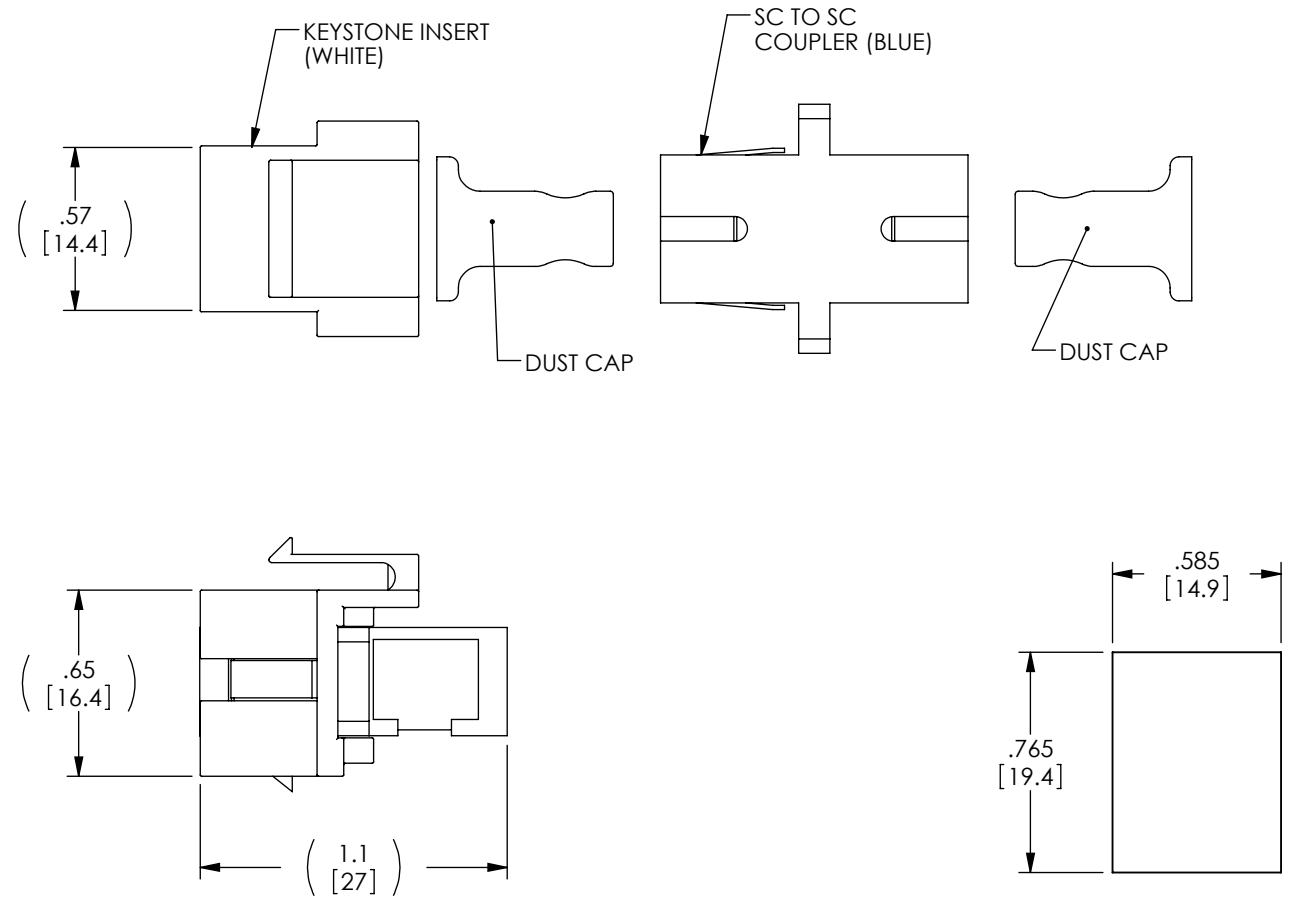

- NOTE:**
1. ALL DIMENSIONS ARE FOR REFERENCE ONLY.
 2. DUST CAPS SHOWN IN TOP (EXPLODED) VIEW ONLY.
 3. COUPLER/INSERT SHIPPED ASSEMBLED WITH DUST CAPS INSTALLED.
 4. COUPLER/INSERT INDIVIDUALLY PACKAGED IN ACCORDANCE WITH L-COM SPEC. PS-0031.

UNLESS OTHERWISE SPECIFIED, DIMENSIONS ARE IN INCHES [mm] OVERALL CABLE LENGTH TOLERANCE: ≤12 [305] = +1 [25] / -0 >12 [305] ≤60 [1524] = +2 [51] / -0 >60 [1524] ≤120 [3048] = +4 [102] / -0 >120 [3048] ≤300 [7620] = +6 [152] / -0 >300 [7620] = +3% / -0%	APPROVALS	DATE		45 BEECHWOOD DRIVE NORTH ANDOVER, MA 01845
	DRAWN BY D. CASTRO	3/15/11		CATEGORY FIBER OPTICS
ALL OTHER DIMENSIONAL TOLERANCES: .X = ±.2 .XX = ±.02 .XXX = ±.005	CHECKED BY D. PARHAM	3/16/11	PRODUCT DESCRIPTION KEYSTONE INSERT SC SIMPLEX	
PROJECTION 	APPROVED BY J. RUST	3/16/11	SIZE A	FSCM NO. 43321
	CONFIGURATION DETAILS OF UNDIMENSIONED FEATURES MAY VARY		DWG. NO. MJSCPSC-WT	REV. A
	COLOR VARIATIONS MAY OCCUR		SCALE: NONE	CAD FILE: MJSCPSC-WT.SLDDRW
				SHEET 1 OF 1