

THE INFORMATION CONTAINED IN THIS DRAWING IS THE SOLE PROPERTY OF L-COM, INC. ANY REPRODUCTIONS IN PART OR WHOLE WITHOUT THE WRITTEN PERMISSION OF L-COM, INC. IS PROHIBITED.

REVISIONS			
REV	DESCRIPTION	DATE	CHANGED BY
A	INITIAL RELEASE	3/17/10	D.GRIFFIN
B	ECN 7712 UPDATE PER VENDOR SPECS	01/05/15	B.FUCHASKI

**FRONT VIEW**

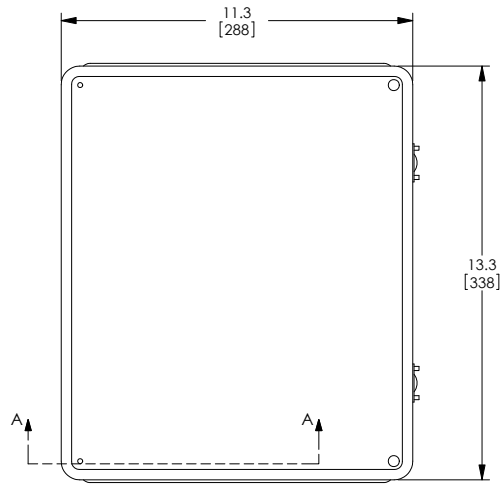

**RIGHT SIDE VIEW**

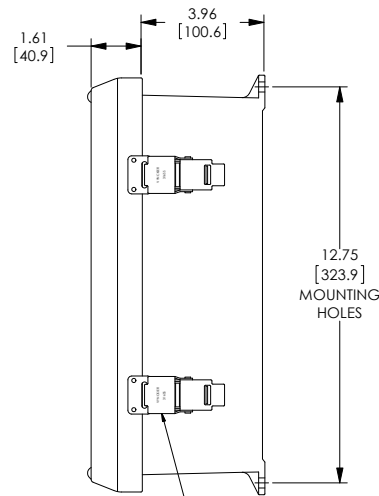

**FRONT VIEW - COVER REMOVED**

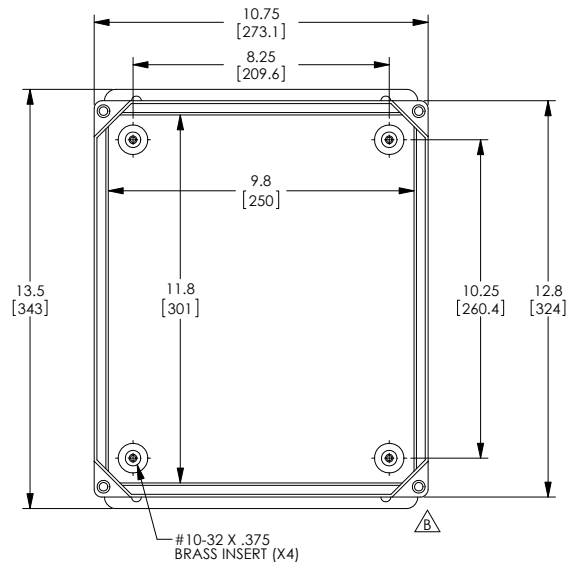

316 STAINLESS STEEL PADLOCK LATCH ATTACHED WITH RIVETS. (Ø.375 PADLOCK EYE)

#10-32 X .375 BRASS INSERT (X4)

**END VIEW**

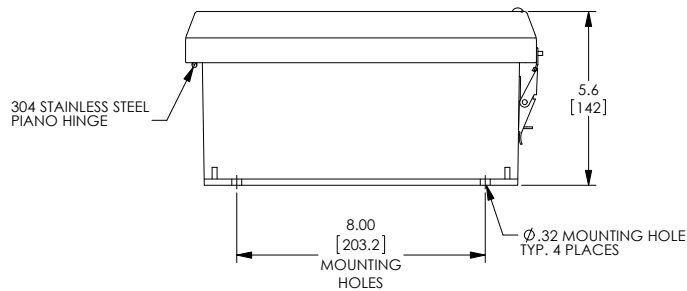

**SECTION A-A**

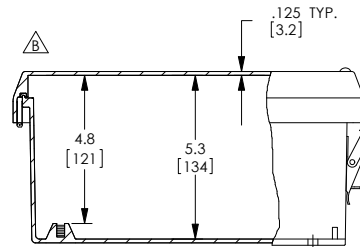

**NOTE:**

- ENCLOSURE MATERIAL-GRAY (RAL7035) HOT MOLDED FIBERGLASS REINFORCED POLYESTER
- NEMA RATED TYPE 3, 3R, 3S, 4, 4X, 12 AND 13 PRIOR TO MODIFICATIONS.
- IEC 529 RATED IP 66 PRIOR TO MODIFICATION.
- TEMPERATURE RANGE FROM -50 DEG C TO 150 DEG C.
- SELF EXTINGUISHING AND HALOGEN FREE.
- CABINETS ARE MAINTENANCE FREE AND CORROSION RESISTANT.
- SHALL BE PACKAGED AS PER L-COM SPEC PKG-00070

**REGULATORY COMPLIANCE:**  
CE2011/65/EU (RoHS DIRECTIVE)

UNLESS OTHERWISE SPECIFIED, DIMENSIONS ARE IN INCHES (mm)	APPROVALS	DATE
OVERALL CABLE LENGTH TOLERANCE: .512 (505) = +1 (25) / -0 >12 (305) ≤60 (1524) = +2 (51) / -0 >60 (1524) ≤120 (3048) = +4 (102) / -0 >120 (3048) ≤300 (7620) = +6 (152) / -0 >300 (7620) = +.96 / -.06	DRAWN BY D. CASTRO	3/11/10
ALL OTHER DIMENSIONAL TOLERANCES: X = ± 2 (5.08) XX = ± .02 (51) XXX = ± .005 (13)	CHECKED BY K. BLOMGREN	3/15/10
PROJECTION	APPROVED BY K. BLOMGREN	3/15/10

CONFIGURATION DETAILS OF UNDIMENSIONED FEATURES MAY VARY	
COLOR VARIATIONS MAY OCCUR	

<b>L-com</b> Global Connectivity		45 BEECHWOOD DRIVE NORTH ANDOVER, MA 01845	
CATEGORY <b>RACK ENCLOSURES</b>			
PRODUCT DESCRIPTION <b>NEMA, Encl 12 X 10 X 5</b>			
SIZE <b>B</b>	PSCM NO. <b>43321</b>	DWG. NO. <b>NB121005</b>	REV. <b>B</b>
SCALE: 1:4		CAD FILE: NB121005.SLDDRW	
			SHEET 1 OF 1