

6

5

4

3

REVISION

1

ZONE	REV	DESCRIPTION	DATE	CHANGED BY	APPROVED
	A	INITIAL RELEASE	01/15/2024	HBAKKE	GUTTADAURO

## WIRING MAP

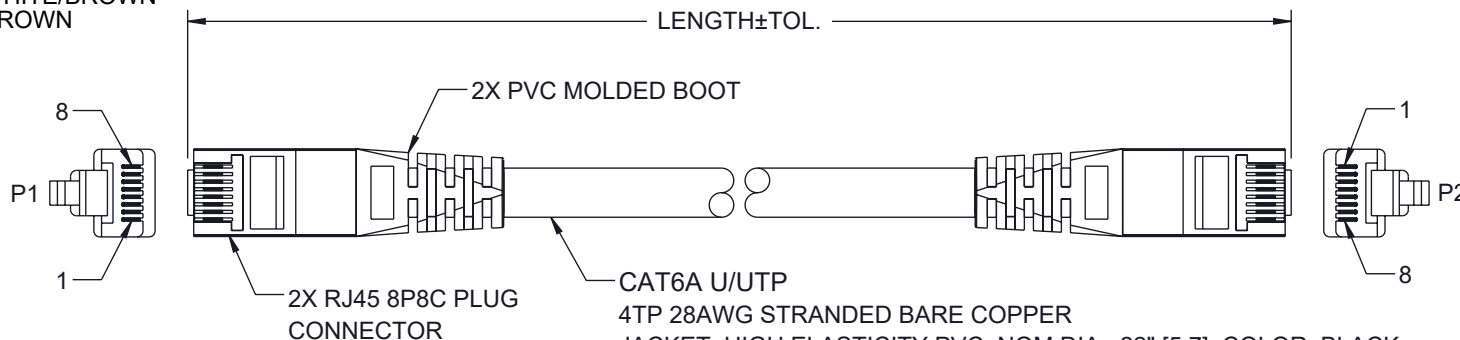
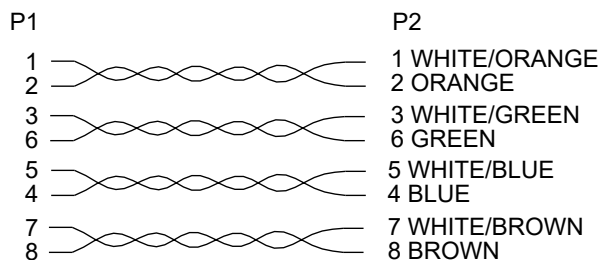

## NOTES:

## PHYSICAL:

- CONDUCTOR TYPE: 28AWG, STRANDED BC
- CONDUCTOR DIA:  $0.60 \pm 0.05$ mm
- CONNECTOR CONTACT MATERIAL: COPPER ALLOY, 50μ" GOLD PLATED
- MINIMUM AVERAGE CABLE THICKNESS: .028 [0.70].

## ELECTRICAL:

- BANDWIDTH: 500 MHz
- VOLTAGE RATING: 30 V
- CONDUCTOR DC RESISTANCE: 28.45Ω/100m (MAXIMUM)
- IMPEDANCE: 100Ω
- CAPACITANCE: 5600pf/100m
- PROPAGATION DELAY: 545ns/100m (MAXIMUM)
- DELAY SKEW: 45ns/100m (MAXIMUM)
- PASS FLUKE DSX 8000 CHANNEL TEST

## ENVIRONMENTAL:

- INSTALLATION TEMPERATURE RATING: 0°C TO +50°C
- OPERATING TEMPERATURE RATING: -20°C TO +60°C

## MISCELLANEOUS:

- CABLE ASSEMBLY TO BE TESTED FOR CONTINUITY.
- CABLE ASSEMBLY SHALL BE INDIVIDUALLY PACKAGED.

## REGULATORY COMPLIANCE:

EU RoHS DIRECTIVE (MOST RECENTLY RELEASED VERSION).

THE INFORMATION CONTAINED IN THIS DRAWING IS THE SOLE PROPERTY OF INFINITE ELECTRONICS, INC. ANY REPRODUCTION IN PART OR WHOLE WITHOUT THE WRITTEN PERMISSION OF INFINITE ELECTRONICS, INC. IS PROHIBITED. THESE COMMODITIES, TECHNOLOGY OR SOFTWARE WERE EXPORTED FROM THE UNITED STATES IN ACCORDANCE WITH THE EXPORT ADMINISTRATION REGULATIONS. DIVERSION CONTRARY TO U.S. LAW PROHIBITED.

ITEM NUMBER	LENGTH [TOL.]	
	FEET [IN]	METERS [mm]
TRD628A-IAC-1F	1.00 [+1.38/- .59]	0.30 [+35/-15]
TRD628A-IAC-2F	2.00 [+1.38/- .59]	0.61 [+35/-15]
TRD628A-IAC-3F	3.00 [+1.38/- .59]	0.91 [+35/-15]
TRD628A-IAC-5F	5.00 [+1.38/- .79]	1.52 [+35/-20]
TRD628A-IAC-7F	7.00 [+1.38/-1.18]	2.13 [+35/-30]
TRD628A-IAC-10F	10.00 [+1.38/-1.18]	3.05 [+35/-30]
TRD628A-IAC-15F	15.00 [+1.38/-1.18]	4.57 [+35/-30]
TRD628A-IAC-25F	25.00 [±2.36]	7.62 [±60]
TRD628A-IAC-50F	50.00 [±3.15]	15.24 [±80]

UNLESS OTHERWISE SPECIFIED  
LEADING DIMENSIONS ARE INCHES  
DIMENSIONS IN [ ] ARE MILLIMETERS

TOLERANCES:  
X = ±.2 [5]      FRACTIONS  
XX = ±.02 [0.5]      ± 1/32  
.XXX = ±.005 [0.13]      ANGLES ± 1°

CABLE LENGTH TOLERANCES:  
≤12 [305] = +1 [25] / -0  
>12 [305] ≤ 60 [1524] = +2 [51] / -0  
>60 [1524] ≤ 120 [3048] = +4 [102] / -0  
>120 [3048] ≤ 300 [7620] = +6 [152] / -0  
>300 [7620] = +5% / -0

ALL DIMENSIONS ARE FOR REFERENCE ONLY  
AND SUBJECT TO CHANGE WITHOUT NOTICE.  
UN-DIMENSIONED/NON-CRITICAL FEATURES  
MAY VARY IN SIZE AND LOCATION  
COLORS MAY VARY

**L-com**  
an INFINIT® brand

Website: www.L-com.com  
Phone: 1.800.341.5266 | 1.978.682.6936



INTERPRET ALL DIMENSIONS AND  
TOLERANCES PER ASME Y14.5

SCALE      SHEET  
NONE      1 OF 1

## DESCRIPTION

CAT 6A ETHERNET CABLE, U/UTP 28AWG, SLIM CABLE WITH  
FLEXIBLE ARMOR JACKET, BLACK

SIZE	CAGE CODE	DRAWN BY	ITEM NO.	REV
A	43321	HBAKKE	TRD628A-IAC	A

6

5

4

3

2

1