

6

5

4

3

2

1

REVISION

ZONE	REV	DESCRIPTION	DATE	CHANGED BY	APPROVED
	B	UPDATED PER ECO-14008	11/14/2024	HBAKKE	GUTTA DAURO

F

F

E

E

D

D

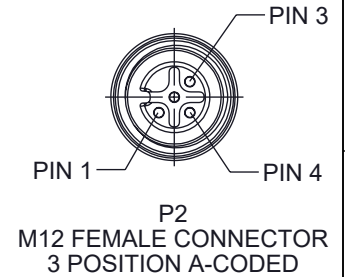
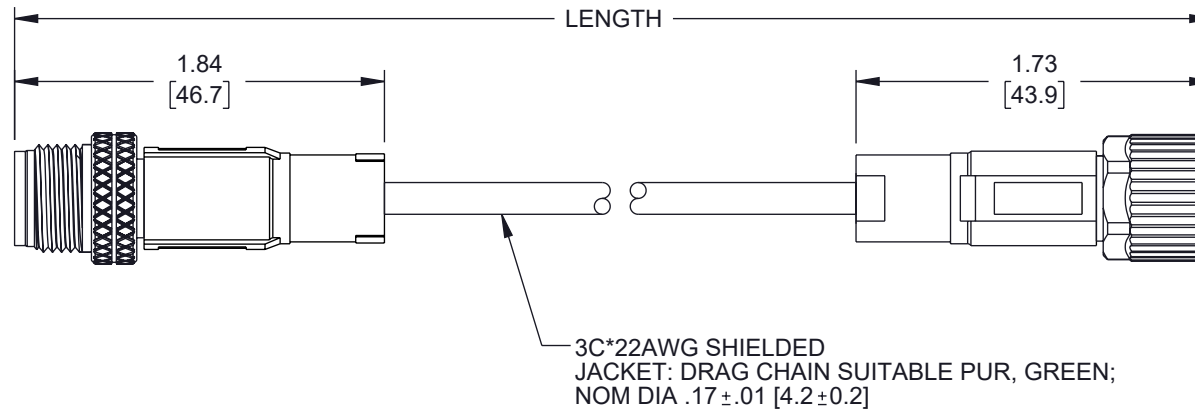
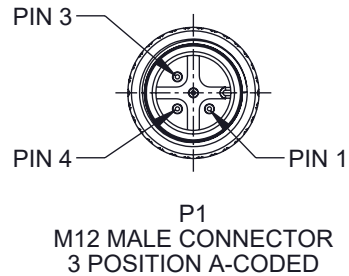

NOTES:

ELECTRICAL:

- NOMINAL VOLTAGE: 300V
- OPERATING VOLTAGE: 60VDC
- OPERATING CURRENT PER CONTACT: 0.5A MAX.

APPLICATION:

- INGRESS PROTECTION RATING IS IP67 (MATED)
- RECOMMENDED TORQUE VALUE: 0.6Nm
- BEND RADIUS FIXED: 33.6mm
- BEND RADIUS MOBILE: 63mm
- TORSION STRESS: ±180°/meter.

ENVIRONMENTAL:

- TEMPERATURE RANGE FIXED: -25°C TO +80°C
- TEMPERATURE RANGE MOBILE: -25°C TO +70°C
- CABLE JACKET RESISTANCE: OIL
- CABLE JACKET FLAME RATING: HB (UL 94).

MISCELLANEOUS

- CABLE ASSEMBLY TO BE TESTED FOR CONTINUITY
- CABLE ASSEMBLY SHALL BE INDIVIDUALLY PACKAGED.

THE INFORMATION CONTAINED IN THIS DRAWING IS THE SOLE PROPERTY OF INFINITE ELECTRONICS, INC. ANY REPRODUCTION IN PART OR WHOLE WITHOUT THE WRITTEN PERMISSION OF INFINITE ELECTRONICS, INC. IS PROHIBITED. THESE COMMODITIES, TECHNOLOGY OR SOFTWARE WERE EXPORTED FROM THE UNITED STATES IN ACCORDANCE WITH THE EXPORT ADMINISTRATION REGULATIONS. DIVERSION CONTRARY TO U.S. LAW PROHIBITED.

P1	WIRE MAP	P1
BROWN 1	—————	1 BROWN
BLUE 3	—————	3 BLUE
BLACK 4	—————	4 BLACK
S	—————	S

ITEM NO	LENGTH [TOL.]	
	METERS [mm]	FEET [IN]
TRGA302S-P2N-05M	0.5 [+35/-15]	1.64 [+1.38/- .59]
TRGA302S-P2N-1M	1 [+35/-20]	3.28 [+1.38/- .79]
TRGA302S-P2N-2M	2 [+35/-30]	6.56 [+1.38/-1.18]
TRGA302S-P2N-3M	3 [+35/-30]	9.84 [+1.38/-1.18]
TRGA302S-P2N-5M	5 [±60]	16.40 [±2.36]
TRGA302S-P2N-10M	10 [±80]	32.81 [±3.15]
TRGA302S-P2N-15M	15 [±80]	49.21 [±3.15]

B

B

A

A

UNLESS OTHERWISE SPECIFIED LEADING DIMENSIONS ARE INCHES DIMENSIONS IN [] ARE MILLIMETERS	
TOLERANCES:	
X = ±.2 [5]	FRACTIONS ± 1/32
.XX = ±.02 [0.5]	ANGLES ± 1°
.XXX = ±.005 [0.13]	
CABLE LENGTH TOLERANCES:	
≤12 [305] = +1 [25] / -0	
>12 [305] ≤ 60 [1524] = +2 [51] / -0	
>60 [1524] ≤ 120 [3048] = +4 [102] / -0	
>120 [3048] ≤ 300 [7620] = +6 [152] / -0	
>300 [7620] = +5% / -0	
ALL DIMENSIONS ARE FOR REFERENCE ONLY AND SUBJECT TO CHANGE WITHOUT NOTICE. UN-DIMENSIONED/NON-CRITICAL FEATURES MAY VARY IN SIZE AND LOCATION COLORS MAY VARY	

L-com
an INFINIT® brand

Website: www.L-com.com
Phone: 1.800.341.5266 | 1.978.682.6936

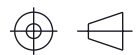

INTERPRET ALL DIMENSIONS AND
TOLERANCES PER ASME Y14.5

SCALE	SHEET
NONE	1 OF 1

DESCRIPTION
M12 3 POLE A CODE, 22AWG, SHD PUR, MF, GRN

SIZE	CAGE CODE	DRAWN BY	ITEM NO.	REV
A	43321	DZINN	TRGA302S-P2N	B

6

5

4

3

2

1