

THE INFORMATION CONTAINED IN THIS DRAWING IS THE SOLE PROPERTY OF L-COM, INC. ANY REPRODUCTION IN PART OR WHOLE WITHOUT THE WRITTEN PERMISSION OF L-COM, INC. IS PROHIBITED.

REVISIONS			
REV	DESCRIPTION	DATE	APPROVED
A	INITIAL RELEASE	11/16/17	G.HUAN

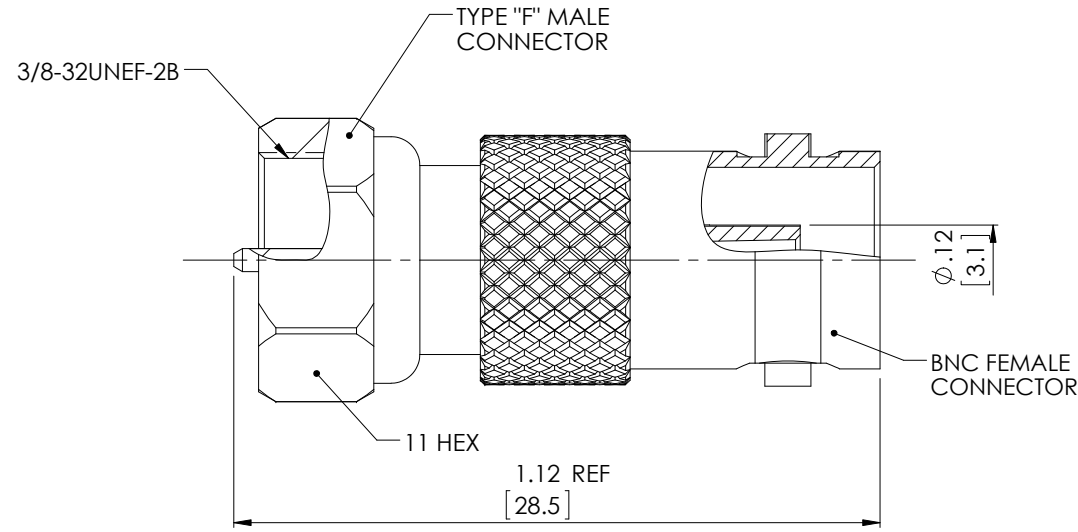

NOTES:

MATERIAL:

BODY:BRASS.
SHELL:BRASS.
CONTACT PIN:PHOSPHOR BRONZE.
INSULATOR:TEFLON(WHITE),DELTRIN(WHITE).
WASHER:BRASS.

FINISH:

BODY,SHELL,WASHER:NICKEL PLATE.
CONTACT PIN:GOLD OVER NICKEL PLATE.

MISCELLANEOUS:

IMPEDANCE:75 OHM.
COMPONENT SHALL BE TESTED FOR CONTINUITY.
COMPONENT SHALL BE INDIVIDUALLY PACKAGED IN ACCORDANCE WITH L-COM SPECIFICATION PS-0031.
ALL DIMENSIONS ARE FOR REFERENCE ONLY.

REGULATORY COMPLIANCE:

CE2011/65/EU(RoHS DIRECTIVE)

UNLESS OTHERWISE SPECIFIED, DIMENSIONS ARE IN INCHES [mm] OVERALL CABLE LENGTH TOLERANCE: ≤12 [305] = +1 [25] / -0 >12 [305] ≤60 [1524] = +2 [51] / -0 >60 [1524] ≤120 [3048] = +4 [102] / -0 >120 [3048] ≤300 [7620] = +6 [152] / -0 >300 [7620] = +5% / -0%	APPROVALS	DATE		50 HIGH STREET NORTH ANDOVER, MA 01845
	DRAWN BY G.HUAN	11/16/17		CATEGORY
ALL OTHER DIMENSIONAL TOLERANCES: .X = ± .2 [5.08] .XX = ± .02 [1.51] .XXX = ± .005 [1.13]	CHECKED BY J.LABOY	11/17/17	PRODUCT DESCRIPTION	
	APPROVED BY B.GATES	11/17/17	ADAPTOR 75 OHM F M TO BNC F	
PROJECTION 	CONFIGURATION DETAILS OF UNDIMENSIONED FEATURES MAY VARY		SIZE A	FSCM NO. 43321
COLOR VARIATIONS MAY OCCUR		DWG. NO. V7C00002	SCALE: NONE	CAD FILE: V7C00002.SLDDRW
			SHEET 1 OF 1	