

2300-2700/5150-5850MHz, 16 / 18 dBi, Wifi MIMO Sector Antenna, 90-degree, +/-45 Dual Pol, 2-Port, Type N Female Connector



HG2358-18XP-090-2NF

Features

- Dual Band frequency coverage for 2300 MHz to 2700 MHz and 5150 MHz to 5850 MHz
- Very High Gain 17 dBi to 20 dBi Directional Antenna with MIMO peak performance antennas
- Supports low-latency, bandwidth-hungry applications like high-definition video and augmented reality/virtual reality applications
- Sector antenna with 2 x Type N Female connectors
- 90° beamwidth with dual +/-45 slant polarization
- 100 W max input power per port
- Easy Install mounting bracket provided
- Weatherproof ABS – UV Resistance PVC radome

Applications

- Outdoor and Indoor dual band Wi-Fi 6 2.4 GHz and 5 GHz applications supported
- Wireless LAN systems & IEEE.802.16ax applications with MU-MIMO and OFDMA
- Wi-Fi 6 and Wi-Fi 6E enables higher data rates up to 35% with enhanced efficiency and speed
- Increased Bandwidth enhances spectral efficiency and supports faster radio applications
- Smart cities expansion for coverage and IOT / IIOT
- Point-to-point (PtP) or point-to-multipoint (PtMP) applications

Description

L-Com's Wi-Fi 6e Sector Antenna HG2358-18XP-090-2NF is in stock and ready to ship on the same-day of order. The frequency range of the HG2358-18XP-090-2NF sector antennas is 2300 MHz to 5850 MHz with a gain of 16-18 dBi. This dual band MIMO antenna supports Wi-Fi latest frequency band and has a 90-degree beam width. The 2-ports 2300-5850 MHz sector antenna include N-type female connectors with +/-45 slant polarization.

The N-type MIMO omni antenna covers a wide range of frequency bands up to 5.8GHz and is shorter than 40-inches for universal zoning compliance. The HG2358-18XP-090-2NF unlicensed Wi-Fi 6 frequency bands sector antenna is "future-proof" in regard to network capabilities without any add-ons. The type N female sector antenna can handle maximum input power of 100 watts and uses universal radio mounts.

The Wi-Fi 6e antenna is 2x2 MIMO ready and offers Dual slant +/- 45 polarizations, degree and 90-degree options and covers extensive frequency bands up to 5.8 GHz. These Wi-Fi 6 antennas are a good fit for the telecommunications industry and for indoor (stadium, large arenas) plus outdoor applications. The HG2358-18XP-090-2NF antennas are equipped with universal radio brackets.

These MIMO multi-port Wi-Fi 6 antennas can operate in the unlicensed bands of 6 GHz. These omni antennas can also operate within the latest Wi-Fi bands of 2.3 GHz to 5.8 GHz.

Contact L-Com's expert technical support for assistance with the Wi-Fi 6e sector antenna or any sector antenna. Download our HG2358-18XP-090-2NF datasheet with specifications and CAD drawing with dimensions for details. Our knowledgeable sales team simplifies the purchasing process and ensures that your Wi-Fi sector antenna cable will be exact to specification.

Order your Wi-Fi 6e Sector Antenna HG2358-18XP-090-2NF from L-com today. There is no MOQ (minimum order quantity) and the product ships same day from our warehouse.

Configuration

Design

Sector

Click the following link (or enter part number in "SEARCH" on website) to obtain additional part information including price, inventory and certifications: [2300-2700/5150-5850MHz, 16 / 18 dBi, Wifi MIMO Sector Antenna, 90-degree, +/-45 Dual Pol, 2-Port, Type N Female Connector HG2358-18XP-](#)

2300-2700/5150-5850MHz, 16 / 18 dBi, Wifi MIMO Sector Antenna,
90-degree, +/-45 Dual Pol, 2-Port, Type N Female Connector



HG2358-18XP-090-2NF

Band Type	Dual
Radiation Pattern	Omni Directional
Polarization	45 Deg. Slant
Connector Type	N Female
Interface 2	N Female
Number of Ports	2
Lightning Protection	DC Grounded

Electrical Specifications

Description	Minimum	Typical	Maximum	Units
Input VSWR			2:1	
Impedance		50		Ohms
Front to Back Ratio	25			dB
Electrical Downtilt		3		Degrees
Port to Port Isolation	25			dB
Input Power			100	Watts

Specifications by Band

Description	Band 1	Band 2	Band 3	Band 4	Band 5	Units
Range	2.3 to 2.7	5.15 to 5.85				GHz
Gain	16	18				dBi
Horizontal HPBW	90	90				Degrees
Vertical HPBW	7	5				Degrees
Port to Port Isolation	25	25				dB
Front to Back Ratio	25	25				dB

Mechanical Specifications

Radome Material	PVC
Size	
Length	35.43 in [899.92 mm]
Width	11.02 in [279.91 mm]
Height	3.14 in [79.76 mm]
Mounting Mast Diameter	1.181 to 2.362 in [30.00 to 59.99 mm]
Weight	1.46 lbs [662.24 g]

2300-2700/5150-5850MHz, 16 / 18 dBi, Wifi MIMO Sector Antenna,
90-degree, +/-45 Dual Pol, 2-Port, Type N Female Connector

HG2358-18XP-090-2NF



Environmental Specifications

Temperature

Operating Range

-40 to +60 deg C

Wind Survivability

134 MPH [215.65 KPH]

Compliance Certifications (see [product page](#) for current document)

Plotted and Other Data

Notes:

2300-2700/5150-5850MHz, 16 / 18 dBi, Wifi MIMO Sector Antenna, 90-degree, +/-45 Dual Pol, 2-Port, Type N Female Connector



HG2358-18XP-090-2NF

Frequency: 2300 MHz

Gain: 15.04 dBi

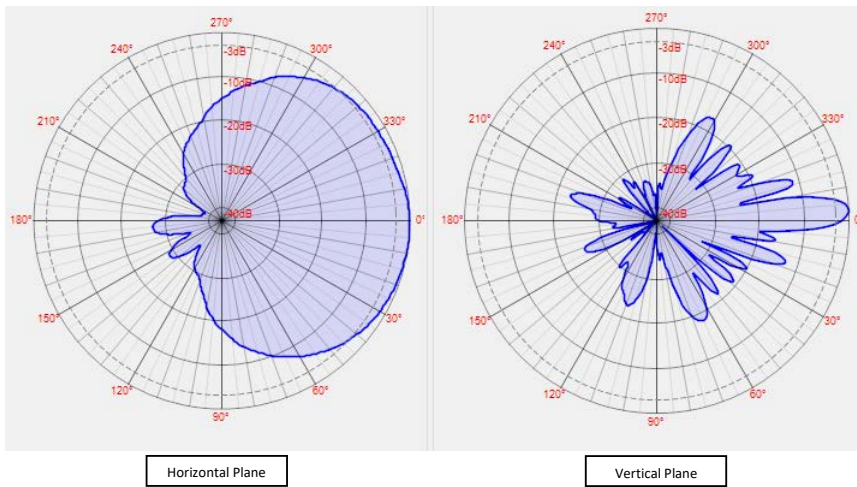

Frequency: 5700 MHz

Gain: 15.20 dBi

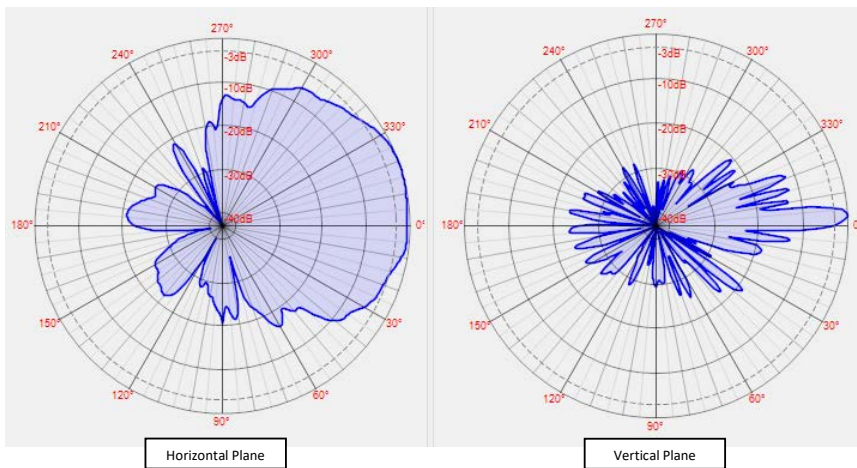

2300-2700/5150-5850MHz, 16 / 18 dBi, Wifi MIMO Sector Antenna, 90-degree, +/-45 Dual Pol, 2-Port, Type N Female Connector from

2300-2700/5150-5850MHz, 16 / 18 dBi, Wifi MIMO Sector Antenna,
90-degree, +/-45 Dual Pol, 2-Port, Type N Female Connector

HG2358-18XP-090-2NF



L-com has same day shipment for domestic and International orders. Our portfolio includes coaxial cable assemblies, connectors, adapters and custom products as well as lightning and surge protectors, NEMA rated enclosures, and an RF product line which includes antennas, amplifiers, passive, and active components.

The information contained within this document is accurate to the best of our knowledge and representative of the part described herein. It may be necessary to make modifications to the part and/or the documentation of the part in order to impliment improvements. L-com reserves the right to make such changes as required. Unless otherwise stated, all specifications are nominal. L-com does not make any representation or warranty regarding the suitability of the part described herein for any particular purpose, and L-com does not assume liability arising out of the use of any part or document.

2300-2700/5150-5850MHz, 16 / 18 dBi, Wifi MIMO Sector Antenna,
90-degree, +/-45 Dual Pol, 2-Port, Type N Female Connector

L-com CAD Drawing

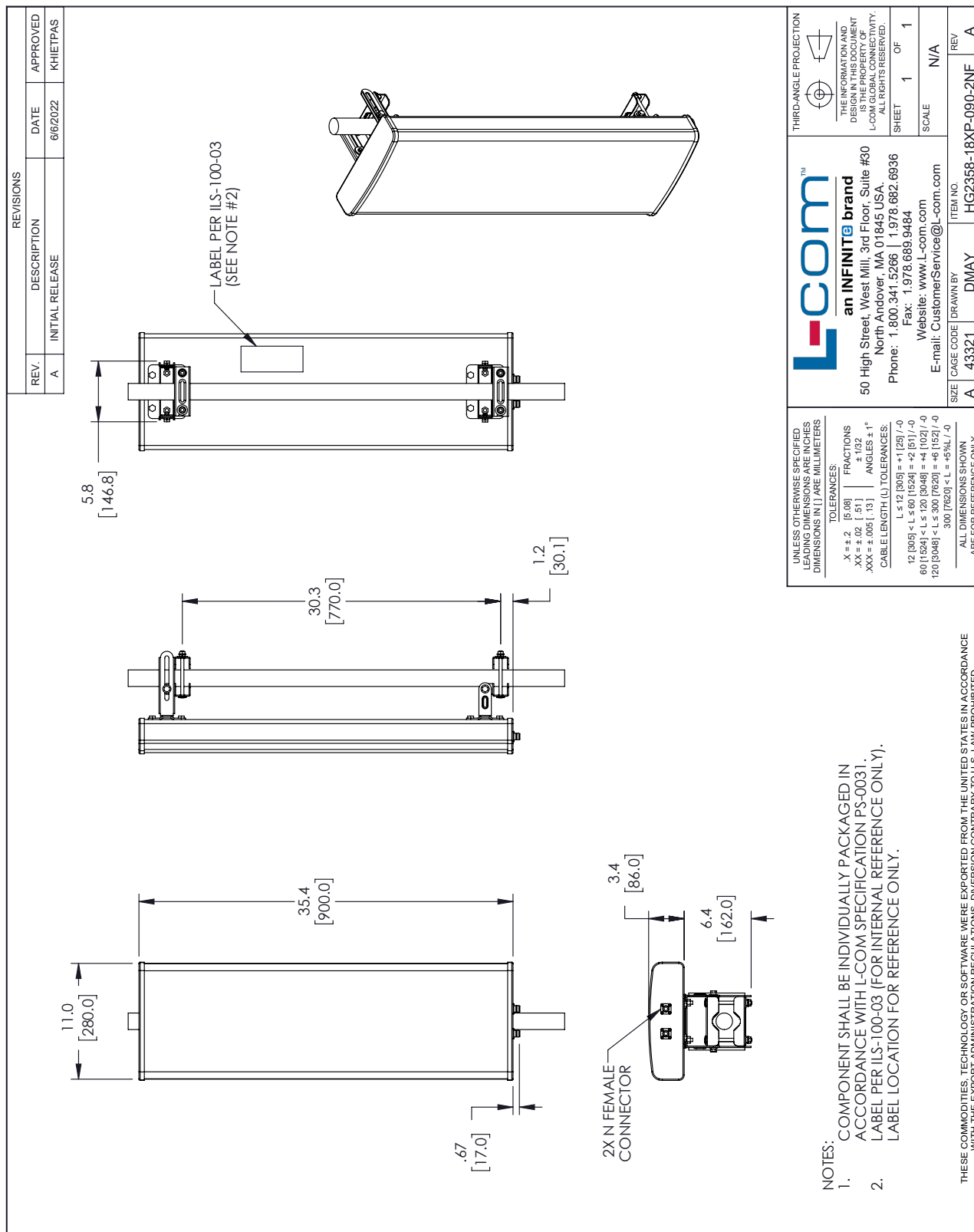

UNLESS OTHERWISE SPECIFIED LEADING DIMENSIONS ARE IN INCHES DIMENSIONS IN [] ARE MILLIMETERS

TOLERANCES:

.X = ±.2 [5.08] FRACTIONS ± 1/32
 .XX = ±.02 [.51] ANGLES ± 1°
 .XXX = ±.005 [.13]

CABLE LENGTH (L) TOLERANCES:

12 [305] < L ≤ 60 [1524] = ±1 [25] / -0
 60 [1524] < L ≤ 120 [3048] = ±4 [102] / -0
 120 [3048] < L ≤ 300 [7620] = ±6 [152] / -0
 300 [7620] < L = +5%L / -0

ALL DIMENSIONS SHOWN ARE FOR REFERENCE ONLY.

THESE COMMODITIES, TECHNOLOGY OR SOFTWARE WERE EXPORTED FROM THE UNITED STATES IN ACCORDANCE WITH THE EXPORT ADMINISTRATION REGULATIONS. DIVERSION CONTRARY TO U.S. LAW PROHIBITED.

L-com™
 an INFINITE brand
 50 High Street, West Mill, 3rd Floor, Suite #30
 North Andover, MA 01845 USA.
 Phone: 1.800.341.5266 | 1.978.682.6936
 Fax: 1.978.689.9484
 Website: www.L-com.com
 E-mail: CustomerService@L-com.com

- NOTES:**
1. COMPONENT SHALL BE INDIVIDUALLY PACKAGED IN ACCORDANCE WITH L-COM SPECIFICATION PS-0031.
 2. LABEL PER ILS-100-03 (FOR INTERNAL REFERENCE ONLY). LABEL LOCATION FOR REFERENCE ONLY.