

Micro Slot Sensor, T-shaped, L.on/D.on selectable, Light on when objects are detected, NPN NO+NC, Sensing distance 5mm, 2m 4-wire cable

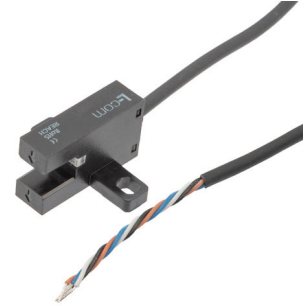

PXSLST-303N-W

Micro Slot Sensor

Features

- Wide power supply range 5-24VDC
- highly accurate and stable
- Selectable light-on/dark-on operation
- IP50 protection
- Easy installation

Applications

- Manufacturing
- Automotive
- Material Handling
- Warehouse Automation

Description

The L-com PXSLST-303N-W micro slot sensor operates on the principle of thru-beam or opposed mode sensing where light emitted from the transmitter is directly aimed at the receiver. Used to detect objects which pass between two arms that make up the slot, the transmitter and receiver share the same T shape housing. Referring to the presence or lack of light at the receiving end, the switching type is L.On/D. On selectable, triggering the NPN output.

General Specifications

Sensing Type	Thru-Beam
Design Type	T Shape
Light Source	Infrared
Output Type	NPN
Sensing Distance	5 mm
Supply Voltage	5-24 VDC
Repeat Accuracy	0.03 mm
IP Rating	IP50
Housing Material	PC
Ambient Brightness	<1,000 Lux
Protective Circuit	Surge protection, Reverse polarity protection
Connection Method	2M 4-wire Cable
Voltage Drop	1.5 V
Electrical Connection	Load Current 100mA, 2m cable length
(For more information please consult User Manual)	Flying Leads

Click the following link (or enter part number in "SEARCH" on website) to obtain additional part information including price, inventory and certifications: [Micro Slot Sensor, T-shaped, L.on/D.on selectable, Light on when objects are detected, NPN NO+NC, Sensing distance 5mm, 2m 4-wire cable](#)

Micro Slot Sensor, T-shaped, L.on/D.on selectable, Light on when objects are detected, NPN NO+NC, Sensing distance 5mm, 2m 4-wire cable



PXSLST-303N-W

Micro Slot Sensor

Circuit Diagram

NPN

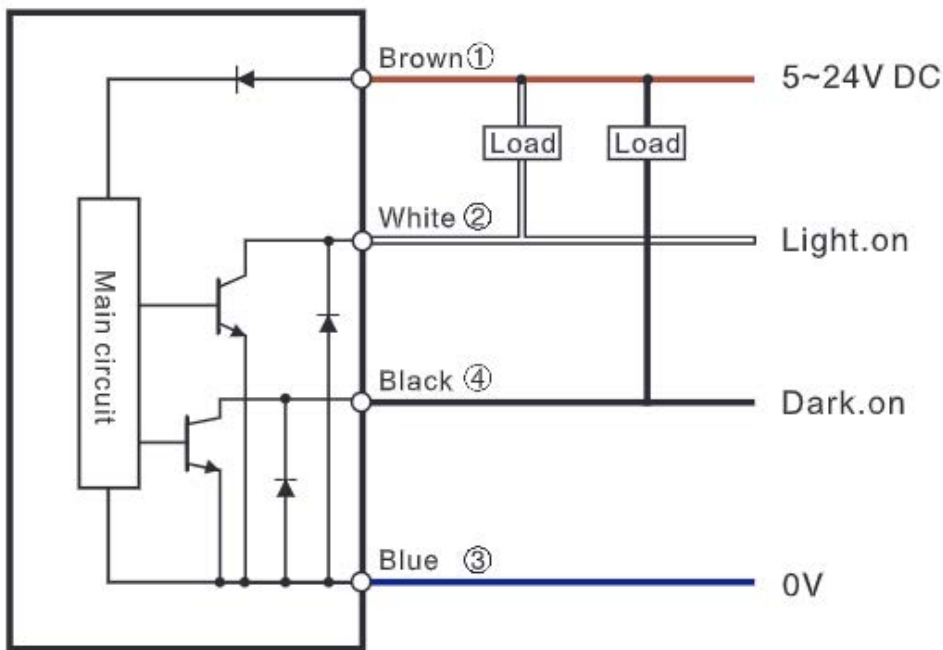

Environmental Specifications

Temperature

Operating Range -25 to +55 deg C
Storage Range -30 to +80 deg C

Humidity

Operating Relative 5% to 85%
Storage Relative 5% to 95%

Micro Slot Sensor, T-shaped, L.on/D.on selectable, Light on when objects are detected, NPN NO+NC, Sensing distance 5mm, 2m 4-wire cable

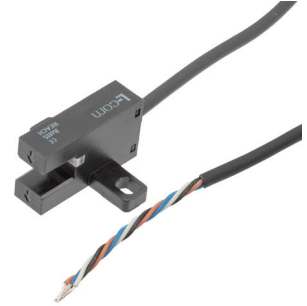

PXSLST-303N-W

Micro Slot Sensor

Micro Slot Sensor, T-shaped, L.on/D.on selectable, Light on when objects are detected, NPN NO+NC, Sensing distance 5mm, 2m 4-wire cable from L-com has same day shipment for domestic and International orders. Our portfolio includes coaxial cable assemblies, connectors, adapters and custom products as well as lightning and surge protectors, NEMA rated enclosures, and an RF product line which includes antennas, amplifiers, passive, and active components.

The information contained within this document is accurate to the best of our knowledge and representative of the part described herein. It may be necessary to make modifications to the part and/or the documentation of the part in order to impliment improvements. L-com reserves the right to make such changes as required. Unless otherwise stated, all specifications are nominal. L-com does not make any representation or warranty regarding the suitability of the part described herein for any particular purpose, and L-com does not assume liability arising out of the use of any part or document.

Micro Slot Sensor, T-shaped, L.on/D.on selectable, Light on when objects are detected, NPN NO+NC, Sensing distance 5mm, 2m 4-wire cable

L-com CAD Drawing

