

## AT-STRIP-01

AT-STRIP-01	Stripping Distance: 4, 6, 8, 10, 12 mm
For use with: RG 58, 59, 62, 6, 174, 316, WBC/LMR® 100, 195, 200, 240	

6 = RG 6 LMR® 240  
 8 = RG 58 LMR® 195, 200  
 9 = RG 59, 62  
 D = RG 174, 316 LMR® 100

Replacement Blades: AT-STRIP-B1

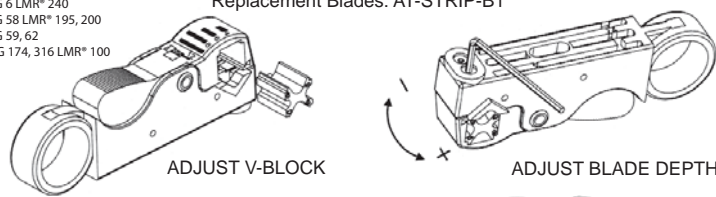

ADJUST V-BLOCK

ADJUST BLADE DEPTH

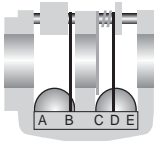

STRIPPING DISTANCE BLADE POSITIONS

C + E = 4 mm  
 B + D = 6 mm (PRESET)  
 B + E = 8 mm  
 A + D = 10 mm  
 A + E = 12 mm

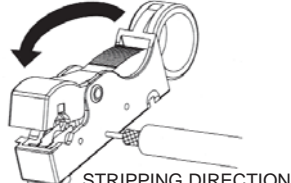

STRIPPING DIRECTION

## AT-STRIP-02

AT-STRIP-02	Stripping Distance: 4, 6, 8, 10, 12 mm
For use with: RG 8, 11, 213, 214, WBC/LMR® 400	

Replacement Blades: AT-STRIP-B2

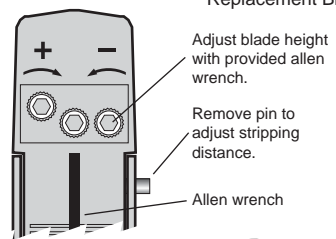

Adjust blade height with provided allen wrench.

Remove pin to adjust stripping distance.

Allen wrench

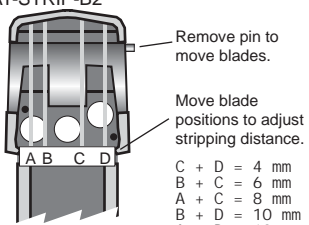

Remove pin to move blades.

Move blade positions to adjust stripping distance.

A B C D

C + D = 4 mm  
 B + C = 6 mm  
 A + C = 8 mm  
 B + D = 10 mm  
 A + D = 12 mm

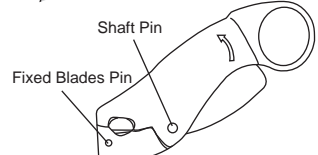

Shaft Pin

Fixed Blades Pin

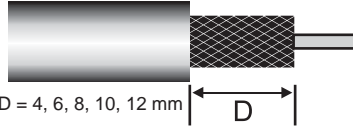

D = 4, 6, 8, 10, 12 mm

STRIPPING DISTANCE

Copyright © This drawing is property of L-com Global Connectivity. All rights reserved.