

Keep this information for further reference.

- Thank you for purchasing an L-COM product.
- Please examine the product for any damaged parts. If any part is damaged or missing, contact L-COM for further assistance. Do not attempt to install or use product if it has been damaged.
- During installation, lay product contents on cardboard or other protective surface to avoid any damage.
- Improper installation or use of this product can result in damage to the product, other equipment, or personal injury. It is recommended that installation to be performed by a qualified installer. L-COM cannot be held responsible for damage to equipment or personal injury resulting from improper use or installation of product. If product is intended to store/ mount equipment, please ensure the equipment stored/ mounted does not exceed the specified weight capacity. Install the heaviest equipment first and install it at the bottom of the rack. Install equipment starting from the bottom of the rack and move upward.
- Limitations of Liability: In no event will L-COM be liable for any damages, whether direct or indirect, special, punitive, incidental or consequential damages (including, but not limited to, lost profits or revenue, loss of use, lost business opportunities or loss of goodwill) or for the cost of procuring substitute products, arising out of or in connection with the use of the product, whether such

liability arises from any claim based upon contract, warranty, tort (including negligence), product liability or otherwise, whether or not seller has been advised of the possibility of such loss or damage. In no event will seller's total cumulative liability, from all causes of action and all theories of liability, exceed the total amounts actually paid to seller by customer under the order that gives rise to any liability hereunder.

## 1. PARTS IDENTIFICATION

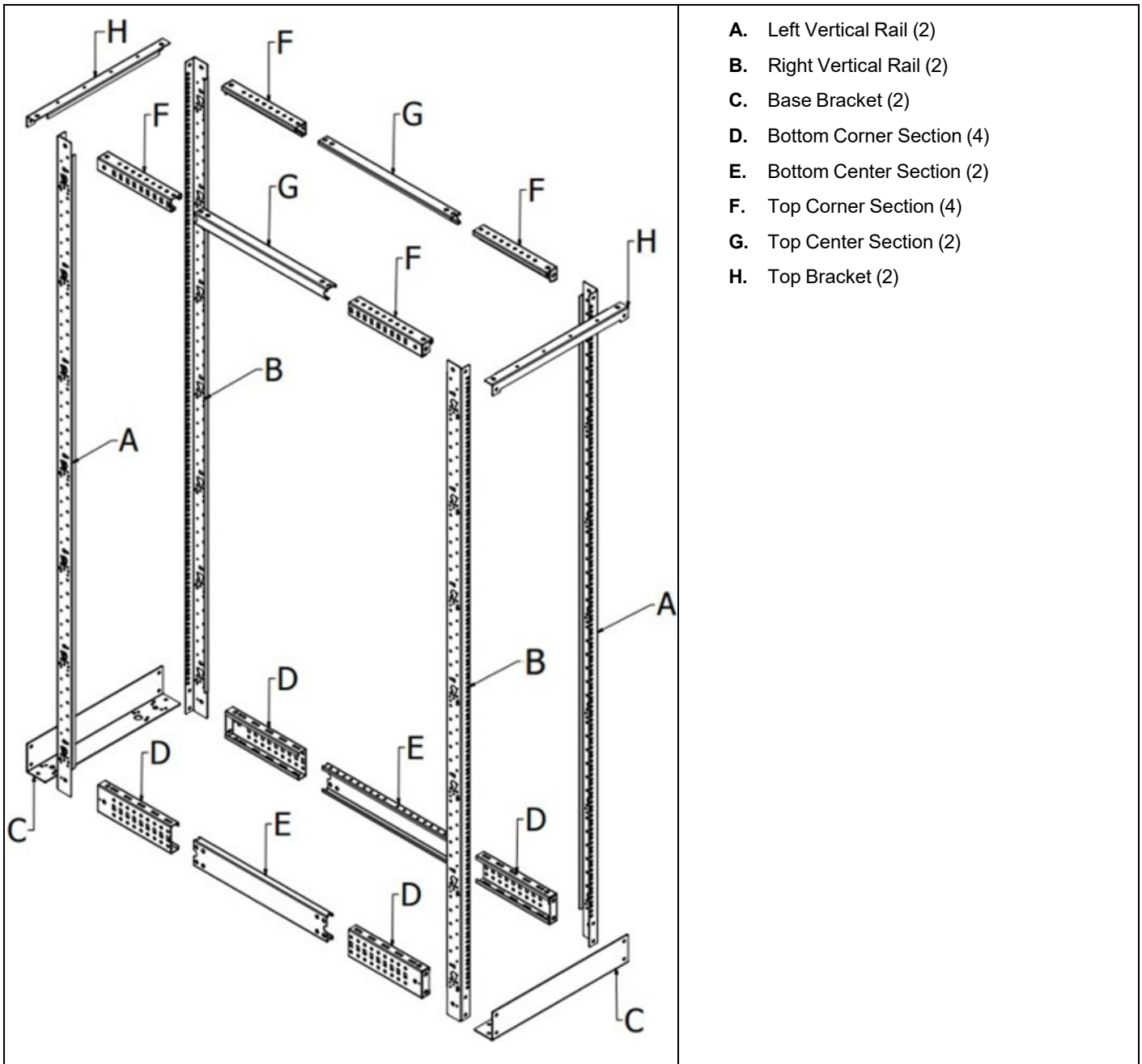

- A. Left Vertical Rail (2)
- B. Right Vertical Rail (2)
- C. Base Bracket (2)
- D. Bottom Corner Section (4)
- E. Bottom Center Section (2)
- F. Top Corner Section (4)
- G. Top Center Section (2)
- H. Top Bracket (2)

I

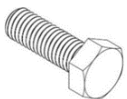

M8 x 16mm Hex  
Screws (x36)

J



M6 Mounting Screws  
12U/18U/22U/25U(x20)  
37U(x30) 42U/45U(x40)

K



M6 Cage Nuts  
12U/18U//22U/25U (x20)  
37U(x30) 42U/45U(x40)

L



M6 Washers  
12U/18U/22U/25U(x20)  
37U(x30) 42U/45U(x40)

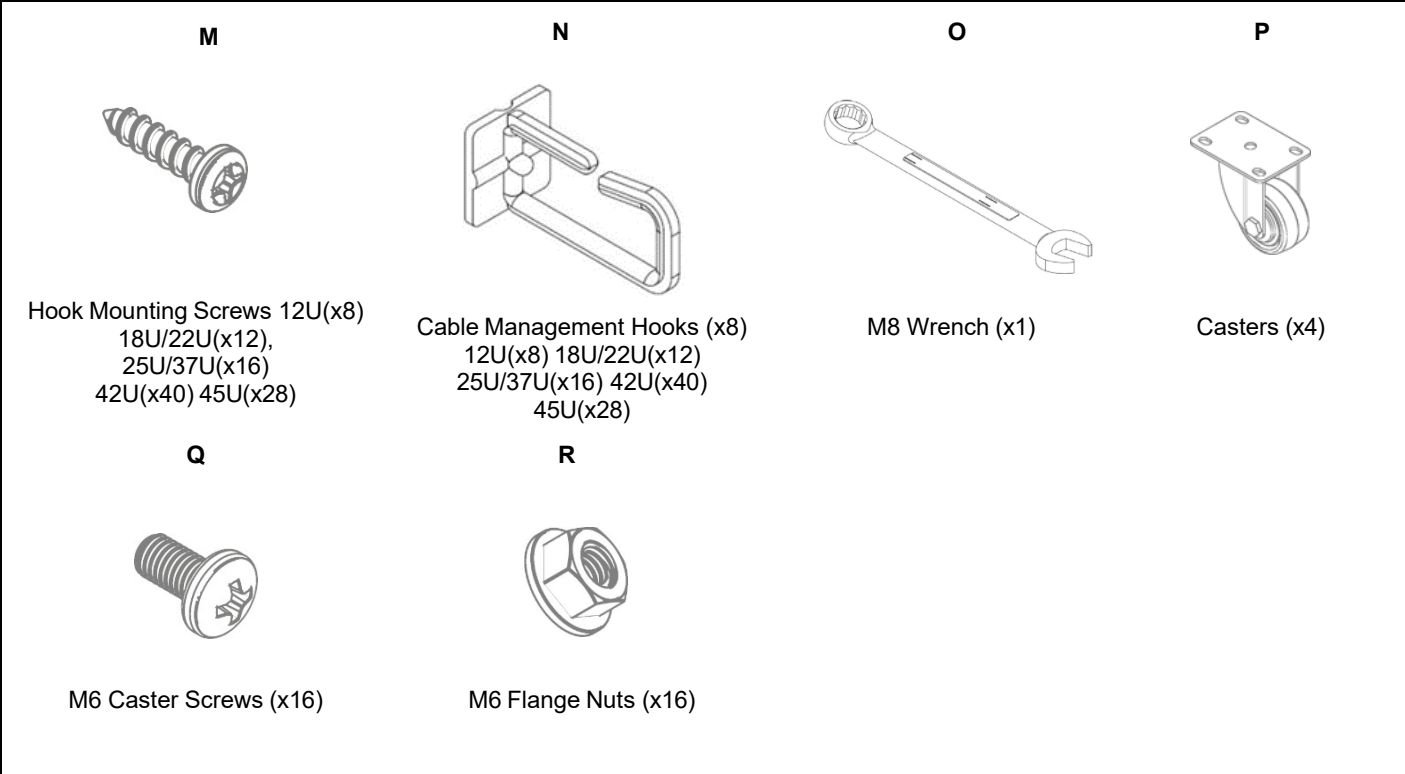

**RACK DEPTH TABLE**

Numbers	Mounting Depth (in)
8 and 8	38
7 and 7	37
6 and 6	36
6 and 7	35
6 and 6	34
5 and 6	33
5 and 5	32
4 and 5	31
4 and 4	30
3 and 4	29
3 and 3	28
2 and 3	27
2 and 2	26
1 and 2	25
1 and 1	24
0 and 1	23
0 and 0	22

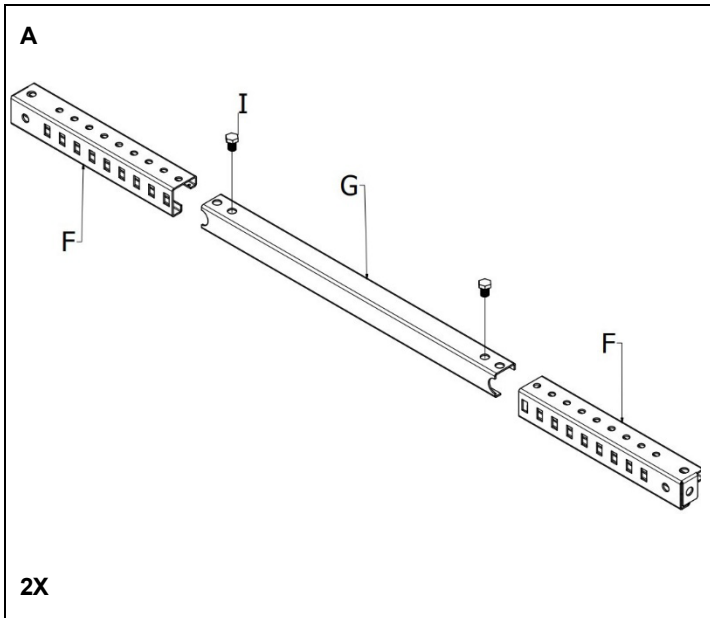

Assemble the top section by sliding two top corner sections (F) over the ends of the top center section (G). Align the pieces so the numbers printed on the center section show through the cutouts in the two top corner sections. The numbers determine the rack's mounting depth. Use the Rack Depth Table (provided above) to assist with determining rack depth. When the sections are aligned at the required depth, secure each section in place with an M8 x 16mm hex screws (I) using M8 wrench (O). Bolts should be fixed in place, but not completely tightened.

Repeat the process to assemble the other top section. Make sure the depths match the other top section.

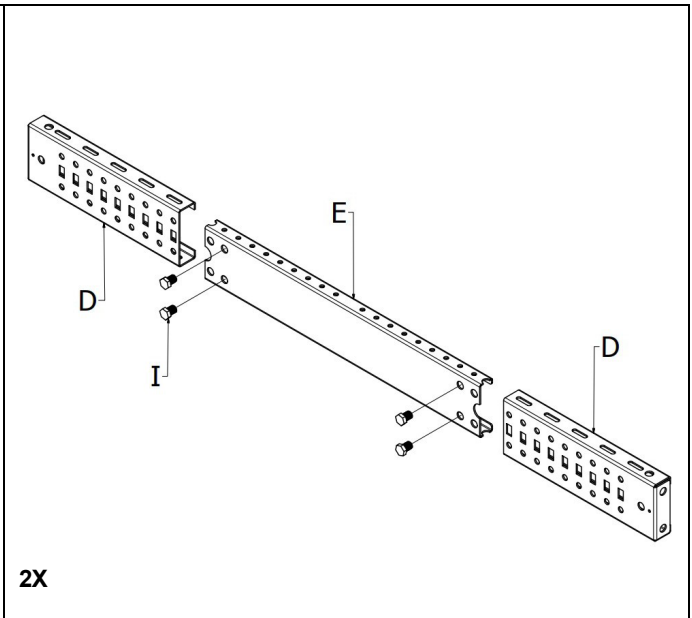

Assemble the bottom section by sliding two bottom corner sections (D) inside the ends of the bottom center section (E). Align the sections so the numbers match the numbers used for the top sections. When the sections are aligned at the required depth, secure each section in place with two M8 x 16mm hex screws (I) using M8 wrench (O). Bolts should be fixed in place, but not completely tightened.

Repeat the process to assemble the other bottom section. Make sure the depths match the other bottom section.

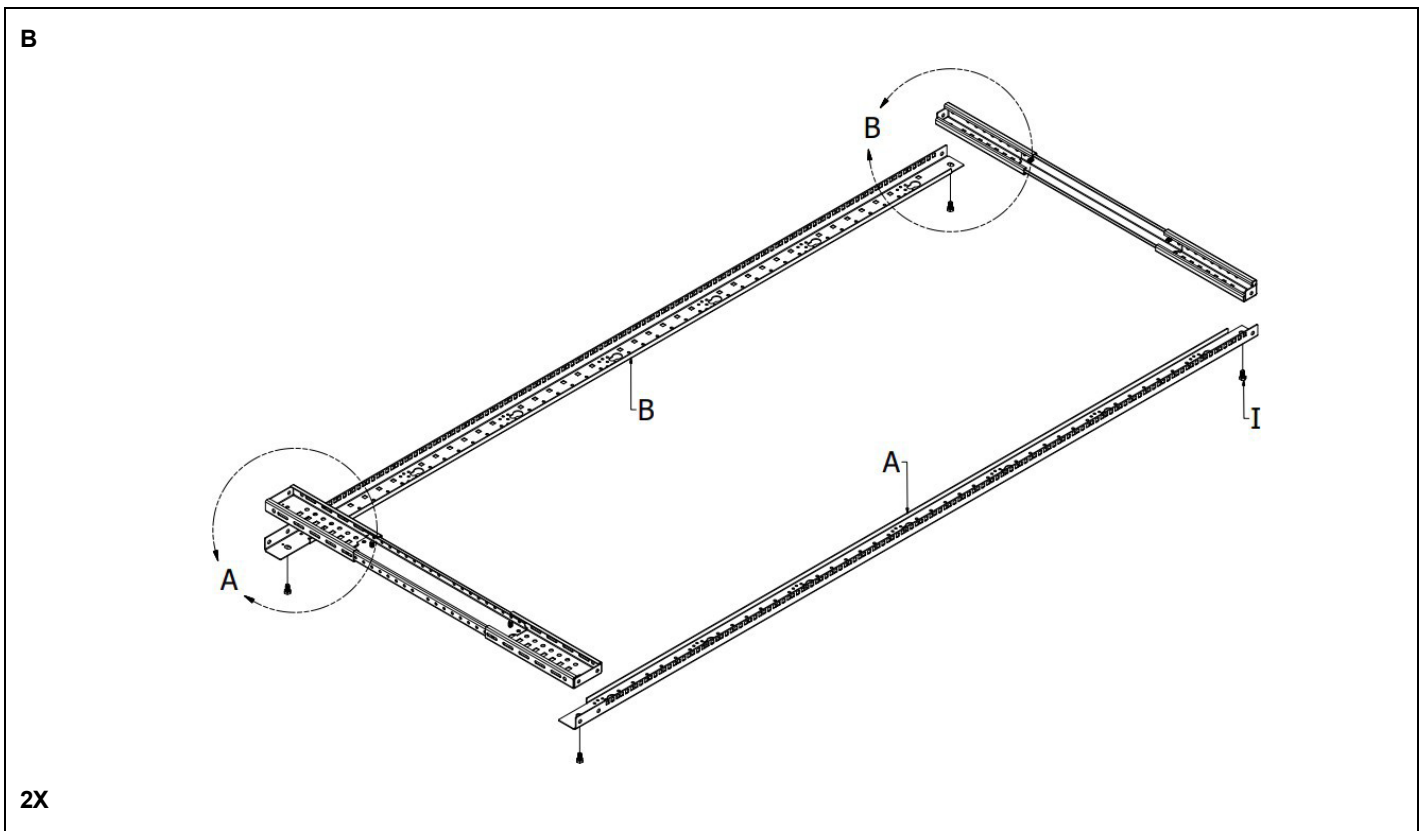

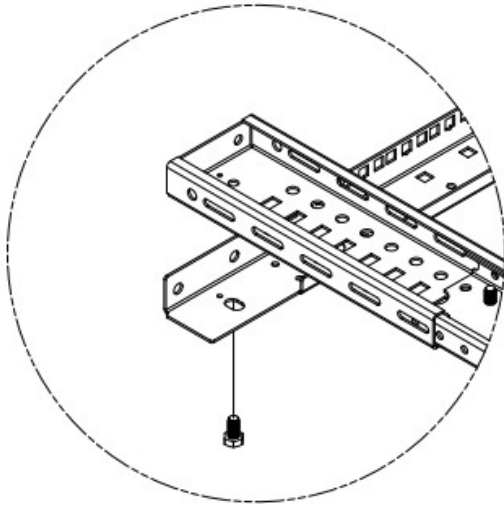

**Detail A**

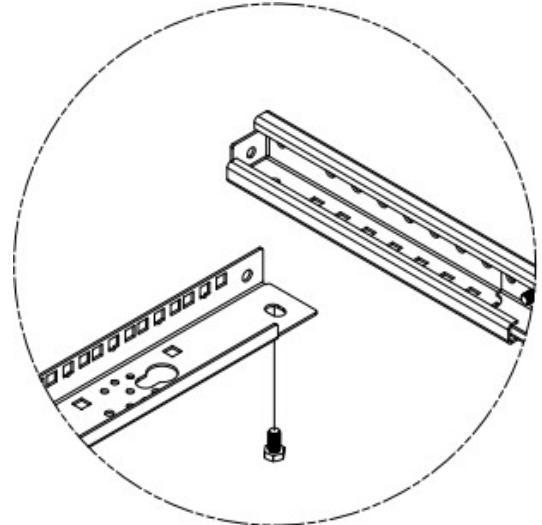

**Detail B**

Lay out the left vertical rail (A), right vertical rail (B), one of the assembled top sections and one of the assembled bottom sections in a rectangle on the floor or other flat surface. Place all the pieces facedown. The assembled top and bottom sections are facedown when the inserted bolt heads are facedown. The vertical rails are facedown when the rails are lying flat on the side that has keyhole mounting slots. Connect the ends of the top and bottom sections with four M8 x 16mm hex screws (I) using M8 wrench (O). Bolts should be fixed in place, but not completely tightened. Repeat the process to build another frame.

C

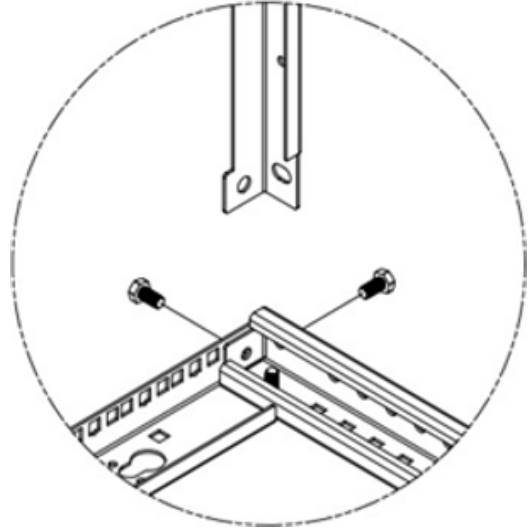
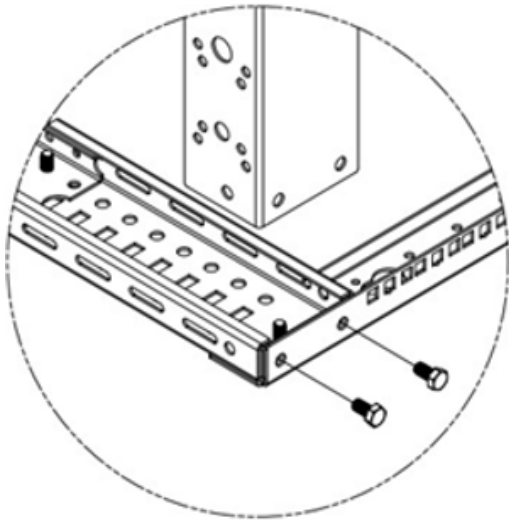
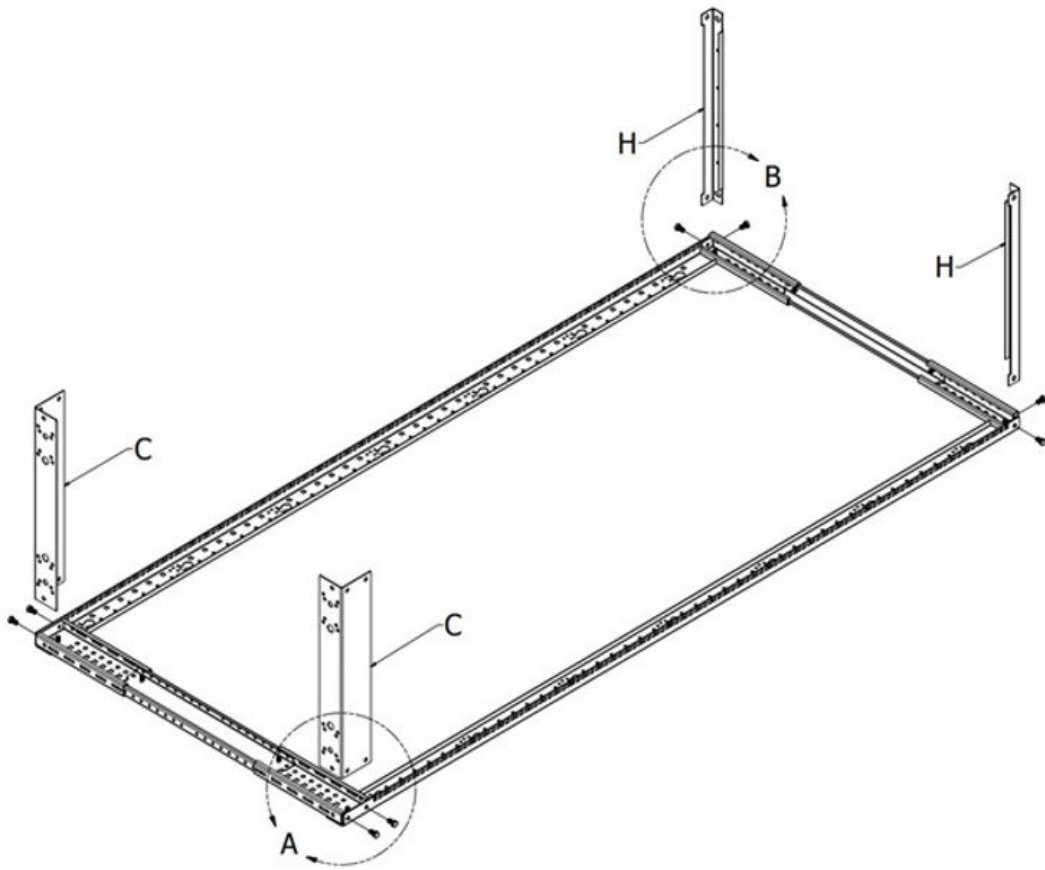

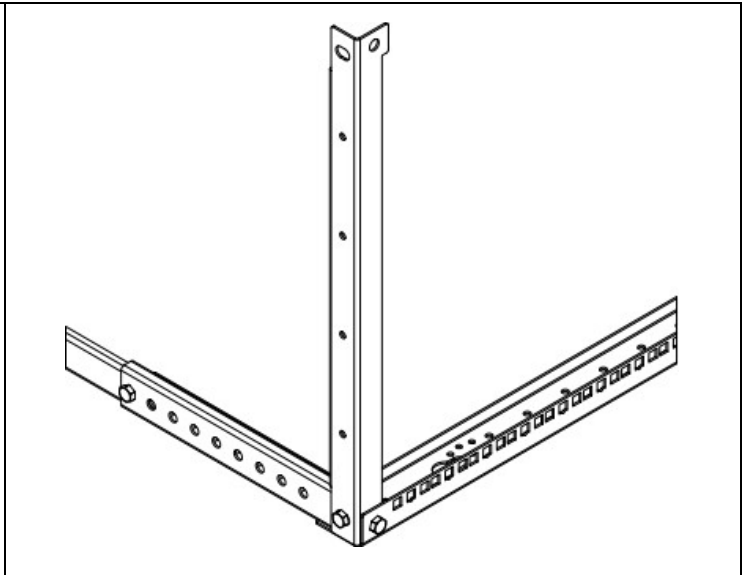
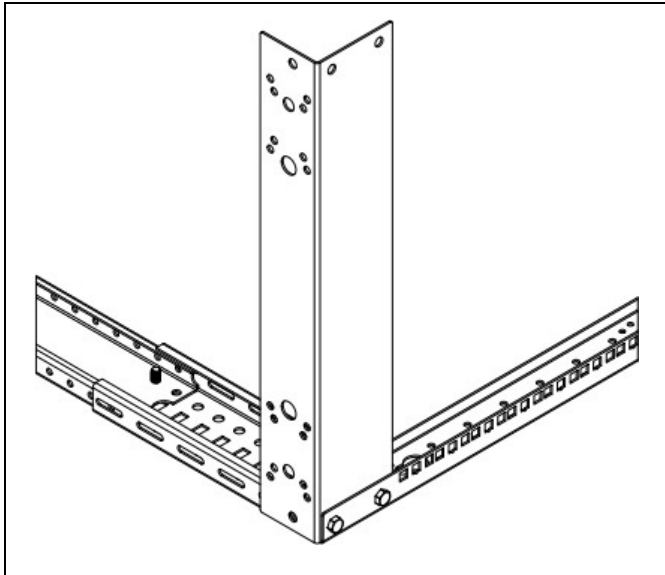

**A:** Insert the base bracket (C) between the assembled bottom section and left (A) right vertical rail (B) and fasten with two M8 x 16mm hex screws (I) using M8 wrench (O). Bolts should be fixed in place, but not completely tightened.

**B:** Insert the top bracket (H) between the assembled top section and left (A) right vertical rail (B) and fasten with two M8 x 16mm hex screws (I) using M8 wrench (O). Bolts should be fixed in place, but not completely tightened.

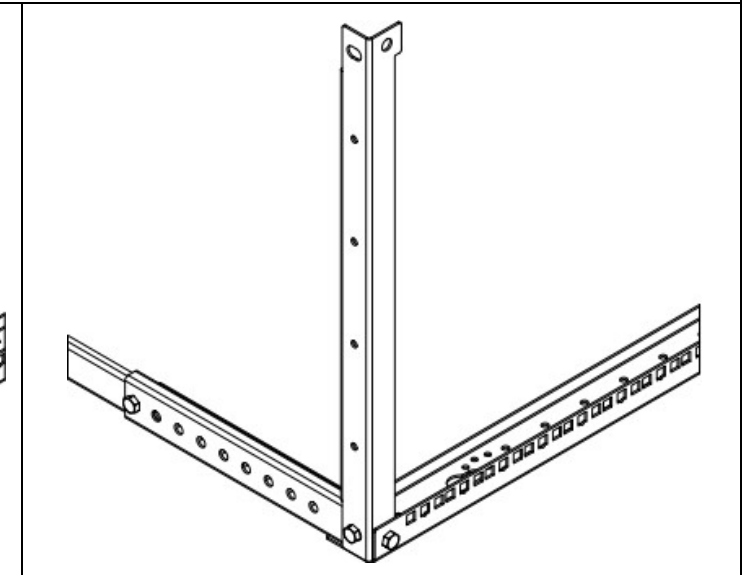
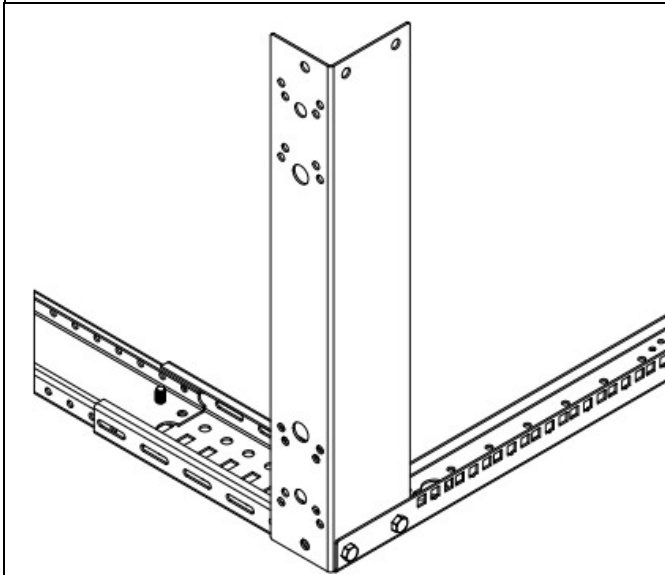

**A:** Insert the base bracket (C) between the assembled bottom section and left (A) right vertical rail (B) and fasten with two M8 x 16mm hex screws (I) using M8 wrench (O). Bolts should be fixed in place, but not completely tightened.

**B:** Insert the top bracket (H) between the assembled top section and left (A) right vertical rail (B) and fasten with two M8 x 16mm hex screws (I) using M8 wrench (O). Bolts should be fixed in place, but not completely tightened.

## 2. OPTIONAL CASTERS

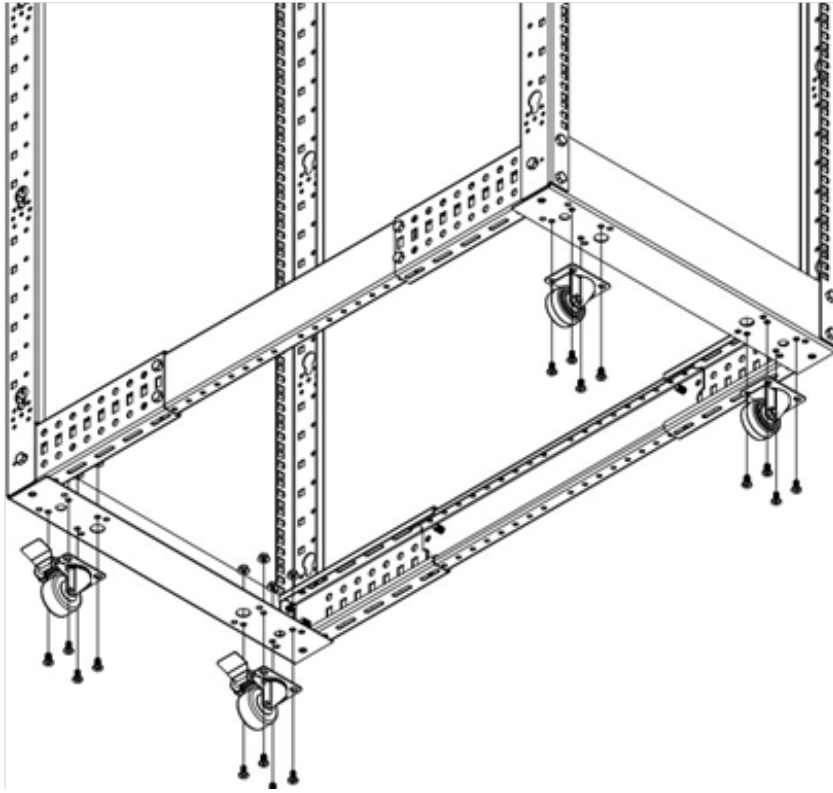

Attach 4 casters (P) to each of the base bracket (C) using 4 of M6 caster screw (Q) and 4 of M6 flange nuts (R) for each caster using a Phillips screwdriver (not included).

Note: 42U and 45U does not come with casters.

## 3. OPTIONAL CABLE MANAGEMENT HOOKS

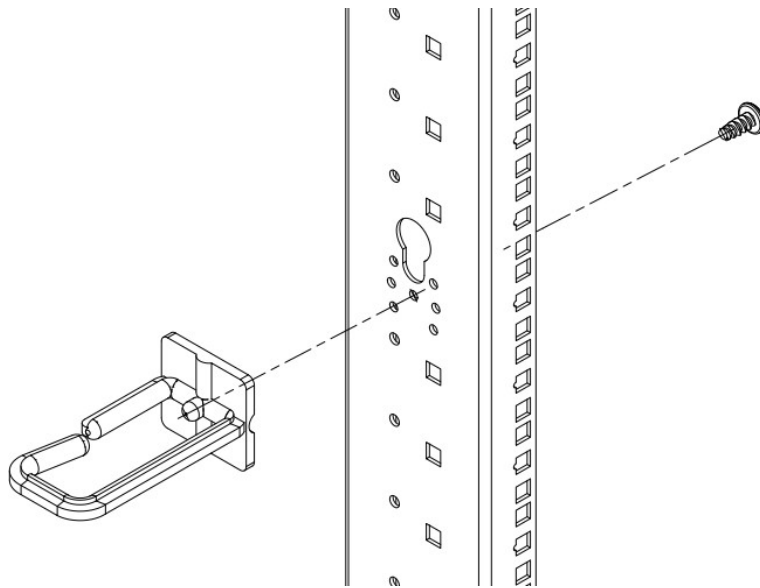

Optional: Fasten the included cable management hooks (N) to the vertical rack rails (B) with the included hook mounting screws (M) using a Phillips Screwdriver (not included).



## 4. EQUIPMENT INSTALLATION

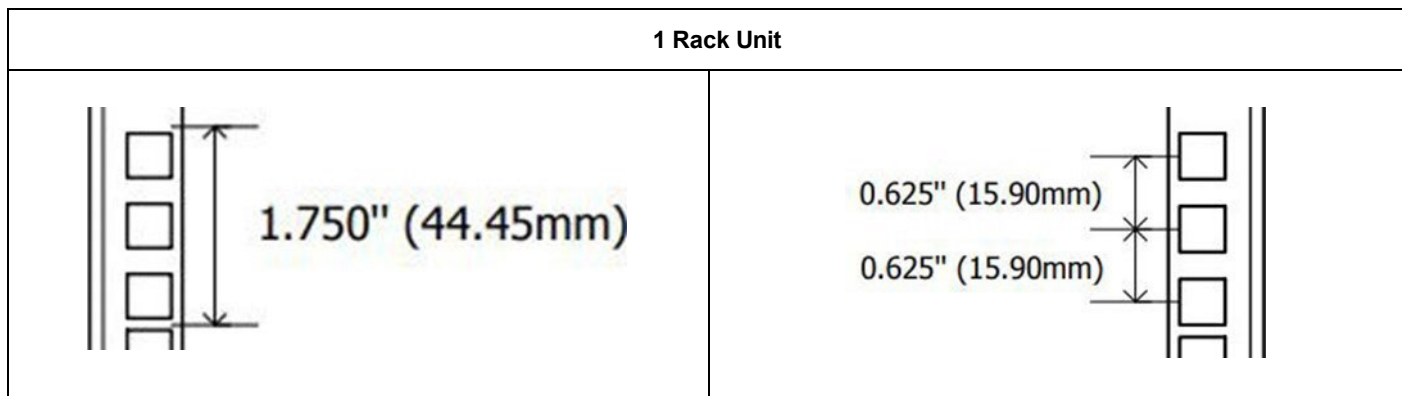

## 5. SQUARED HOLE MOUNTING

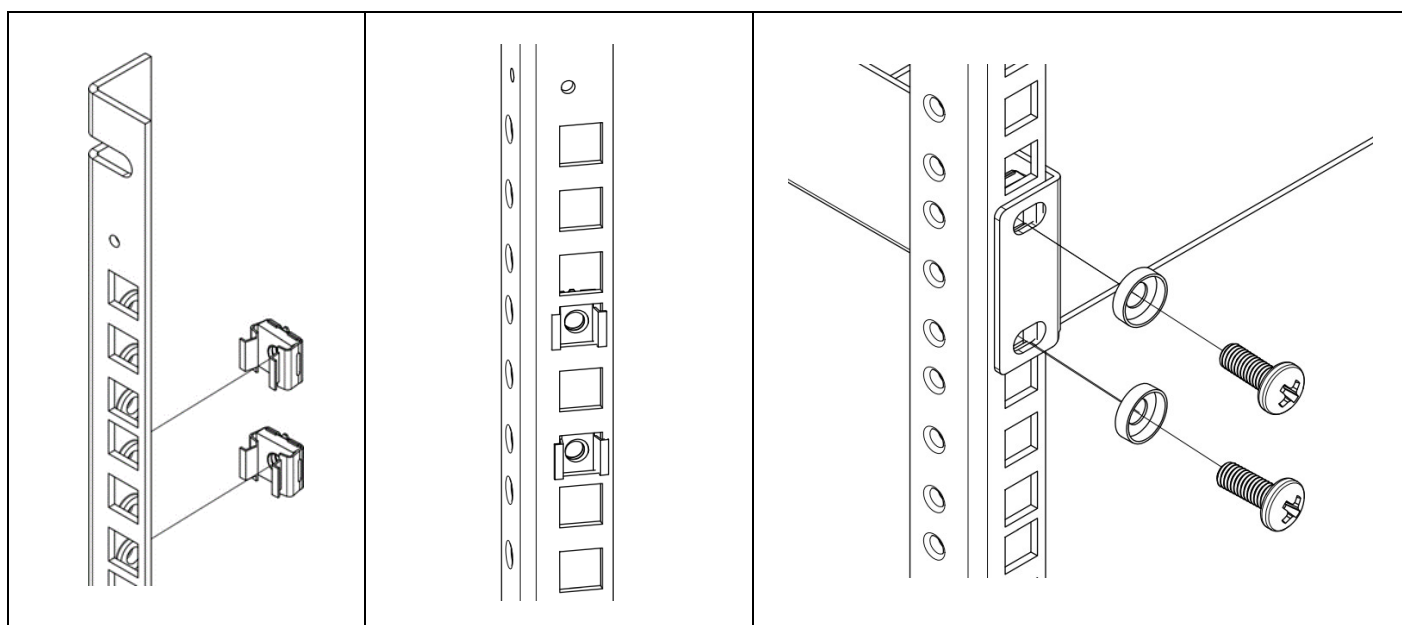

1. Locate the numbered square openings in the mounting rails where the user plans to install the equipment. Install cage nuts (included) into the square openings to provide an attachment point for the mounting screws (included). Note: Consult user equipment documentation to determine the number of cage nuts required and where they will be installed.
2. From the inside of the mounting rail, insert one of the flanges of the cage nut through the square opening. Press it against the side of the square opening. Each flange should engage one side of the square opening, not the top or bottom.
3. Compress the cage nut at the sides slightly to allow the remaining flange to fit through the square opening. When the cage nut is properly installed, both flanges will protrude through the square opening and will be visible on the outer surface of the mounting rail. Repeat steps 2 and 3 until all required cage nuts are installed.
4. After installing the required cage nuts, use the included black mounting screws and cup washers to secure the equipment to the rack rail. Place the cup washers between the screws and the equipment mounting brackets.