

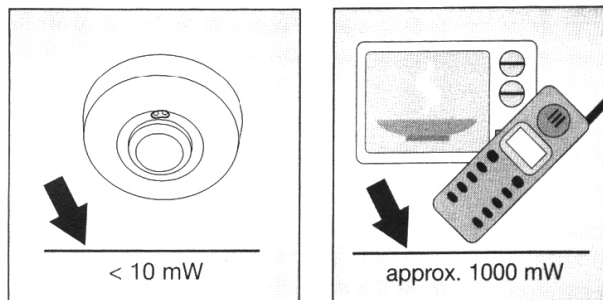

This sensor is an active motion detector that emits high-frequency electromagnetic waves (5.8GHz) and receives their echo. It can detect the change in echo caused by even the slightest movement in its detection zone. A microprocessor then triggers the “switch light ON” command.

The sensor offers detection through various objects like doors, panes of glass or thin walls. Additionally, a person or object moving towards the sensor is detected more efficiently.

NOTE: The high-frequency output of this sensor is <10mW - that is just one-100th of the transmission power of a mobile phone or the output of a microwave oven.

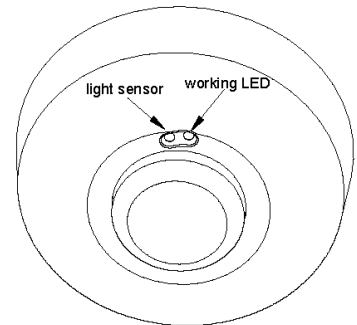

INSTALLATION PROCEDURES

1. Take off the top cover by turning it anti-clockwise (see fig.1), and then fix the middle cover using two screws (see fig.2).
2. Hold the base against the wall and mark where holes need to be drilled, paying attention to any existing wiring in the wall.
3. Drill the holes and insert the wall plugs (6mm dia).
4. Put the power wire and load wire through the base holes.
5. Screw the base into place (see fig.3).
6. Connect the main power supply and the load wire to the connection terminal according to connection-wire mark.
7. Close the middle cover (see fig.3) and adjust the knob.
8. Fit the glass shade and turn it clockwise (see fig.3).

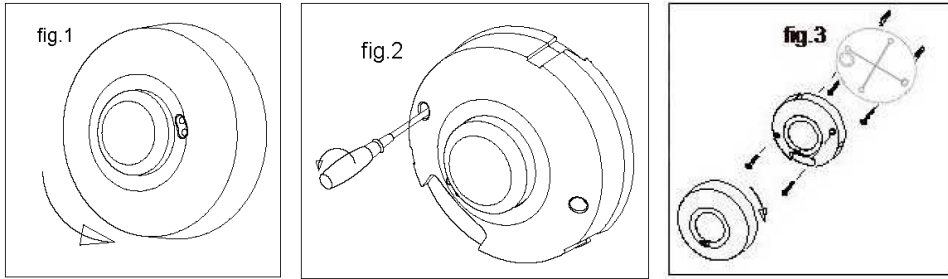

TECHNICAL SPECIFICATIONS

Power Supply	110-130 VAC (-1) / 220-240 VAC (-2)
Hold Time	8sec-12min, adjustable
Detect distance (radii.)	2-10m, adjustable
Daylight Sensor	2-2000lux, adjustable
Detection Angle	360°×160°
IP65	
Size	∅ 11.6x5.6cm

CONNECTION ILLUMINATION

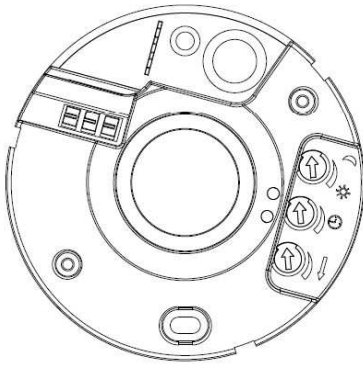

Connect N, L with power
Connect N, L' with load

Reach setting (sensitivity)

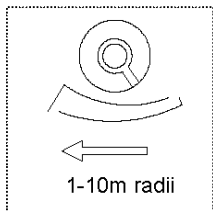

Reach is the term used to describe the radii of the circular detection zone produced on the ground after mounting the sensor light at a height of 2.5m. Turn the reach control fully anticlockwise to select minimum reach (approx. 1m radii), and fully clockwise to select maximum reach (approx. 10m radii).

NOTE: the above detection distance applies in the case of a person who is between 1.6m~1.7m tall with medium built and moves at a speed of 1.0~1.5m/sec. If the person's stature, built and moving speed change, the detection distance will also change.

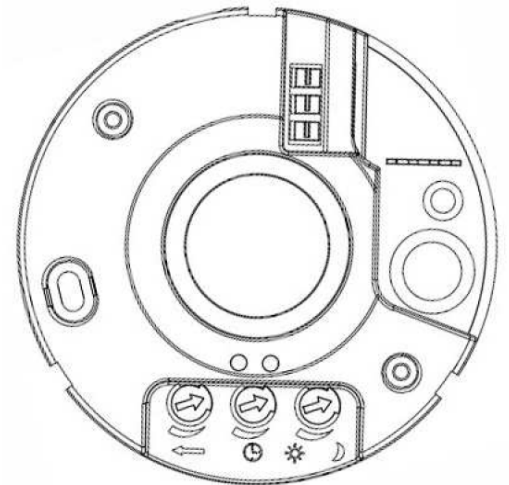

Time setting

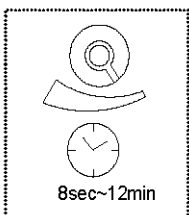

The light can be set to stay ON for any period between 8sec (turn fully anticlockwise) and 12min (turn fully clockwise). Any movement detected before this time range will re-start the timer. It is recommended to select the shortest time for adjusting the detection zone and for performing the walk test.

NOTE: after the light switches OFF, it takes approx. 1sec before it can start detecting movement again. The light will only switch ON in response to movement once this period has elapsed.

Light-control setting

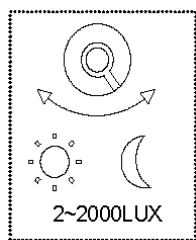

The chosen light response threshold can be infinite from approx. 2-2000lux. Turn it fully anti-clockwise to select dusk-to-dawn operation at about 2 lux. Turn it fully clockwise to select daylight operation at about 2000lux. The knob must be turned fully clockwise when adjusting the detection zone and performing the walk test in daylight.

TROUBLESHOOTING

Malfunction	Cause	Remedy
The load does not work	<ul style="list-style-type: none"> • Wrong light-control setting selected 	<ul style="list-style-type: none"> • Adjust setting
	<ul style="list-style-type: none"> • Load faulty 	<ul style="list-style-type: none"> • Change load
	<ul style="list-style-type: none"> • Mains switched OFF 	<ul style="list-style-type: none"> • Switch mains ON
The load works continuously	<ul style="list-style-type: none"> • Continuous movement in the detection zone 	<ul style="list-style-type: none"> • Check zone setting
The load works without any identifiable movement	<ul style="list-style-type: none"> • The sensor is not mounted to detect movement reliably 	<ul style="list-style-type: none"> • Check zone setting
	<ul style="list-style-type: none"> • Movement occurred, but not identified by the sensor (movement behind wall, movement of a small object in immediate lamp vicinity, etc.) 	
The load does not work despite movement	<ul style="list-style-type: none"> • The movement is rapid, or the detection zone is too small. 	<ul style="list-style-type: none"> • Check zone setting