

ARDUINO Open Source Programmable Logic Controller PLCARD21DP



Purpose of the manual

The information contained in this manual can be used as a reference to operating, to functions, and to the technical data of the signal modules, power supply modules and interface modules.

Intended Audience

This User Guide is intended for the following audience:

- Persons in charge of introducing automation devices.
- Persons who design automation systems.
- Persons who install or connect automation devices.
- People who manage working automation installation.



Warnings:

- Unused pins should not be connected. Ignoring the directive may damage the controller.
- Improper use of this product may severely damage the controller.
- Refer to the controller's User Guide regarding wiring considerations.
- Before using this product, it is the responsibility of the user to read the product's User Guide and all accompanying documentation.
- Maintenance must be performed by qualified personnel familiarized with the construction, operation, and hazards involved with the control.
- Maintenance should be performed with the control out of operation and disconnected from all sources of power.
- Care should be taken when servicing electrostatic sensitive components. The manufacturer's recommendations for these components should be followed.
- The L-com Family PLCs are Open Type Controllers. It is required that you install the L-com PLC in a housing, cabinet, or electric control room. Entry to the housing, cabinet, or electric control room should be limited to authorized personnel. Failure to follow these installation requirements could result in severe personal injury and/or property damage. Always follow these requirements when installing L-com family PLCs.
- In case of installation or maintenance of the L-com PLC please follow the instructions marked in the Installation and Maintenance section.
- Do not disconnect equipment when a flammable or combustible atmosphere is present. Disconnection of equipment when a flammable or combustible atmosphere is present may cause a fire or explosion which could result in death, serious injury and/or property damage.



Avertissements:

- Les broches non utilisées ne doivent pas être connectées. Ignorer la directive peut endommager le contrôleur.
- Une utilisation incorrecte de ce produit peut endommager gravement le contrôleur.
- Reportez-vous au Guide de l'utilisateur du contrôleur pour les considérations de câblage.
- Avant d'utiliser ce produit, il incombe à l'utilisateur de lire le Guide de l'utilisateur du produit et la documentation qui l'accompagne.
- La maintenance doit être effectuée par personnel qualifié familiarisé avec la fabrication, le fonctionnement et les dangers liés au contrôleur.
- La maintenance doit être effectuée avec l'équipement hors service et déconnectée de toutes les sources d'alimentation.
- Faites attention lors de l'entretien des composants sensibles à l'électricité statique. Les recommandations du fabricant pour ces composants doivent être suivies.
- Les automates de la famille L-com sont des contrôleurs de type ouvert. Il est nécessaire d'installer l'automate L-com dans un boîtier, une armoire ou une salle de contrôle électrique. L'accès au boîtier, à l'armoire ou à la salle de commande électrique doit être limité au personnel autorisé. Le non-respect de ces exigences d'installation peut entraîner des blessures graves et/ou des dommages matériels importants. Respectez toujours ces exigences lors de l'installation des automates de la famille L-com.
- En cas d'installation ou de maintenance du L-com, veuillez suivre les instructions indiquées dans la section Installation et Maintenance.
- Ne débranchez pas l'équipement en présence d'une atmosphère inflammable ou combustible. La déconnexion de l'équipement en présence d'une atmosphère inflammable ou combustible peut provoquer un incendie ou une explosion pouvant entraîner la mort, des blessures graves et/ou des dommages matériels.

Application Considerations and Warranty

Reading and Understanding this Manual

Please read and understand this manual before using the product. Please consult your comments or questions to LCOM before using the product.

Application Consideration

THE PRODUCTS CONTAINED IN THIS DOCUMENT ARE NOT SAFETY RATED. THEY SHOULD NOT BE RELIED UPON AS A SAFETY COMPONENT OR PROTECTIVE DEVICE FOR ENSURING SAFETY OF PERSONS, AS THEY ARE NOT RATED OR DESIGNED FOR SUCH PURPOSES.

Please know and observe all prohibitions of use applicable to the products. FOR AN APPLICATION INVOLVING SERIOUS RISK

TO LIFE OR PROPERTY

WITHOUT ENSURING THAT THE SYSTEM AS A WHOLE HAS BEEN DESIGNED

TO ADDRESS THE RISKS, NEVER USE THE LCOM PRODUCTS.

NEVER USE THE LCOM PRODUCTS BEFORE THEY ARE PROPERLY RATED AND INSTALLED FOR THE INTENDED USE WITHIN THE OVERALL EQUIPMENT OR SYSTEM.

LCOM shall not be responsible for conformity with any codes, regulations or standards that apply to the combination of products in the customer's application or use of the product.

The following are some examples of applications for which particular attention must be given. This is not intended to be an exhaustive list of all possible uses of the products, nor is it intended to imply that the uses may be suitable for the products:

- Systems, machines, and equipment that could present a risk to life or property.
- Nuclear energy control systems, combustion systems, railroad systems, aviation systems, medical equipment, amusement machines, vehicles, safety equipment, and installation subject to separate industry or government regulations.
- Outdoor use, uses involving potential chemical contamination or electrical interference, or conditions or uses not described in this document.

At the customer's request, LCOM will provide applicable third-party certification documents identifying ratings and limitations of use that apply to the products. This information by itself is not sufficient for a complete determination of the suitability of the products in combination with the system, machine, end product, or other application or use.

Intended use or of LCOM products.

Consider the following:

LCOM products should only be used for the cases of application foreseen in the catalogue and the associated technical documentation. If third-party products and components are used, they must have been recommended or approved by LCOM.

The correct and safe operation of the products requires that your transport, storage, installation, assembly, operation and maintenance have been carried out in a correct way. It must respect the permissible ambient conditions. You should also follow the indications and warnings that appear in the associated documentation.

The product / system dealt with in this documentation should only be handled or manipulated by qualified personnel for the task entrusted and observing what is indicated in the documentation corresponding to it, particularly the safety instructions and warnings included in it. Due to their training and experience, qualified personnel are in a position to recognize risks resulting from the handling or manipulation of such products / systems and to avoid possible hazards.

Disclaimers

Weights and Dimensions

Dimensions and weights are nominal and they are not used for manufacturing purposes, even when tolerances are shown.

Performance Data

The performance data given in this manual is provided as a guide for the user in determining suitability and does not constitute a warranty. It may represent the result of LCOM's test conditions, and the users must correlate it to actual application requirements. Actual performance is subject to the LCOM Warranty and Limitations of Liability.

Errors and Omissions

The information in this document has been carefully checked and is believed to be accurate; however, no responsibility is assumed for clerical, typographical, or proofreading errors, or omissions.

The control and drive components of LCOM PLC are approved for industrial and commercial use in industrial line supplies. Their use in public line supplies requires a different configuration and/or additional measures. These components may only be operated in closed housings or in higher-level control cabinets with protective covers that are closed, and when all of the protective devices are used. These components may only be handled by qualified and trained technical personnel who are knowledgeable and observe all of the safety information and instructions on the components and in the associated technical user documentation. When carrying out a risk assessment of a machine in accordance with the EU Machinery Directive, the machine manufacturer must consider the following residual risks associated with the control and drive components of a PDS.

1. Unintentional movements of driven machine components during commissioning, operation, maintenance, and repairs caused by, for example:
 - Hardware defects and/or software errors in the sensors, controllers, actuators, and connection technology
 - Response times of the controller and drive – Operating and/or ambient conditions not within the scope of the specification – Condensation / conductive contamination – Parameterization, programming, cabling, and installation errors – Use of radio devices / cellular phones in the immediate vicinity of the controller – External influences / damage.
2. Exceptional temperatures as well as emissions of noise, particles, or gas caused by, for example: – Component malfunctions – Software errors – Operating and/or ambient conditions not within the scope of the specification – External influences / damage.
3. Hazardous shock voltages caused by, for example: – Component malfunctions – Influence of electrostatic charging – Induction of voltages in moving motors – Operating and/or ambient conditions not within the scope of the specification – Condensation / conductive contamination – External influences / damage
4. Electrical, magnetic and electromagnetic fields generated in operation that can pose a risk to people with a pacemaker, implants or metal replacement joints, etc. if they are too close.
5. Release of environmental pollutants or emissions as a result of improper operation of the system and/or failure to dispose of components safely and correctly.

Warranty and Limitations of Liability

Warranty

LCOM's exclusive warranty means that the products are free from defects in materials and workmanship for a period of one year (or other period if specified) from date of sale by LCOM.

LCOM MAKES NO REPRESENTATION OR WARRANTY, EXPRESSED OR IMPLIED, REGARDING MERCHANTABILITY, NON-INFRINGEMENT, OR FITNESS FOR PARTICULAR PURPOSE OF THE PRODUCTS. ANY BUYER OR USER ACKNOWLEDGES THAT THE BUYER OR USER ALONE HAS DETERMINED THAT THE PRODUCTS WILL SUITABLY MEET THE REQUIREMENTS OF THEIR INTENDED USE. LCOM DISCLAIMS ALL OTHER WARRANTIES, EXPRESS OR IMPLIED

Limitations of Liability

LCOM SHALL NOT BE RESPONSIBLE FOR SPECIAL, INDIRECT, OR CONSEQUENTIAL DAMAGES, LOSS OF PROFITS OR COMERCIAL LOSS IN ANY WAY CONNECTED WITH THE PRODUCTS, WHETHER SUCH CLAIM IS BASED ON CONTRACT, WARRANTY, NEGLIGENCE, OR STRICT LIABILITY.

IN NO EVENT SHALL LCOM BE RESPONSIBLE FOR WARRANTY, REPAIR OR OTHER CLAIMS REGARDING THE PRODUCTS UNLESS LCOM'S ANALYSIS CONFIRMS THAT THE PRODUCTS WERE PROPERLY HANDLED, STORED, INSTALLED, AND MAINTAINED AND NOT SUBJECT TO CONTAMINATION, ABUSE, MISUSE, OR INAPPROPRIATE MODIFICATION OR REPAIR.

**RECOGNIZED
COMPONENT**



Intertek

Conforms to UL Std.
61010-1 Conforms to UL
Std. 61010-2-201 Certified
to CSA Std. C22.2 No.
61010-1
Certified to CSA Std. C22.2 No. 61010-2-201

Table of Contents

1	General Description	7
1.1	Zone - Nomenclature	7
1.2	Zone Distribution.....	7
1.3	A Zone Features.....	8
1.4	Mechanical dimension	8
1.5	General Features.....	9
2	Technical Specifications:	10
2.1	General Specifications:	10
2.2	Performance Specification	10
2.3	Symbology.....	11
3	Precautions	12
3.1	Arduino Board	12
3.2	Intended Audience.....	12
3.3	General Precautions	12
4	Software interface	12
5	How to connect PLC Arduino to PC.....	12
6	How to connect PLC to power supply	13
7	Arduino PLC Family Pinout	15
7.1	A Zone connection.....	15
7.2	B Zone (Analog Shield).....	16
8	Switch Configuration.....	17
8.1	A Zone: Communications.....	17
8.2	B, C & D Zone Switchces	18
9	Arduino I/Os 5V pins	19
9.1	I2C pins – SDA/SCL	19
9.2	Serial 0 – RX0/TX0.....	19
9.3	Serial 1 – RX1/TX1.....	19
9.4	SPI – MISO/MOSI/SCK	20
9.5	Pin 2/Pin 3.....	20
10	A Zone Features: Communications & RTC & uSD	20
10.1	RS-232	20
10.2	RS-485	20
10.3	I2C.....	20
10.4	SPI	20
10.5	TTL.....	21
10.6	Ethernet.....	21
10.7	RTC.....	21
10.8	uSD	21
11	Instructions for interconnection between LCOM controllers	23
11.1	RS-232 Communication	23
11.2	RS-485 Communication	23
11.2.1	Half Duplex.....	23
11.2.2	Full Duplex.....	23
11.3	Ethernet.....	23
12	I/O technical details:	24
13	Typical Connections	26
14	Connector details:.....	29
15	Mechanical Characteristics	30
16	Installation and Maintenance.....	31

1. General Description

1.1. Zone - Nomenclature

The nomenclature shown in this point will be used in the whole User Guide, so it is important to understand this nomenclature.

The nomenclature to differentiate the zones is based on the Alphabet, being A the shield from below and B the shield from above. It has 2 zones (A, B):

- The inputs in zone B are named I0.X, being X any number suitable in the Shield. Outputs are named Q0.X.



1.2. Zone Distribution

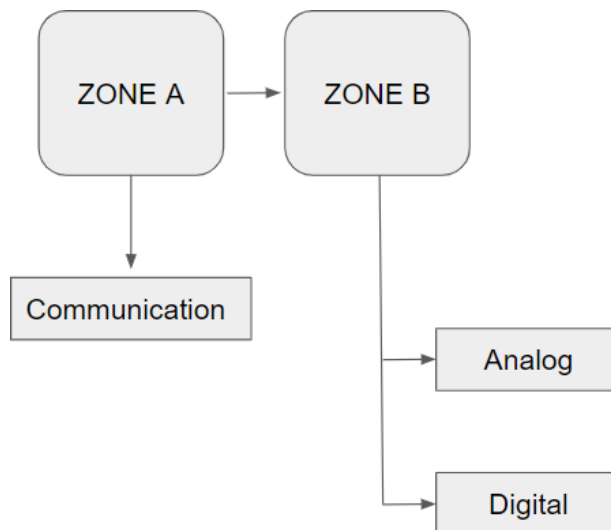

The distribution of the different features that provide the M-Duino 21 I/Os PLUS is the following one:

Shield	B Zone
Analog Shield	<p>13 Inputs (13 Digital inputs, 6 of which can work as Analog Input)</p> <p>8 Outputs (8 Digital Outputs, 3 of which can work as Analog Output)</p>

1.3. A Zone Features

Shield	A Zone
Communication Shield	<p>(1x) Ethernet (1x) USB (1x) I2C (3x) TTL (1x) RS-232 (1x) HALF/FULL Duplex RS-485 (1x) SPI external Port (1x) RTC (1x) uSD Socket</p>

1.4. Mechanical dimension

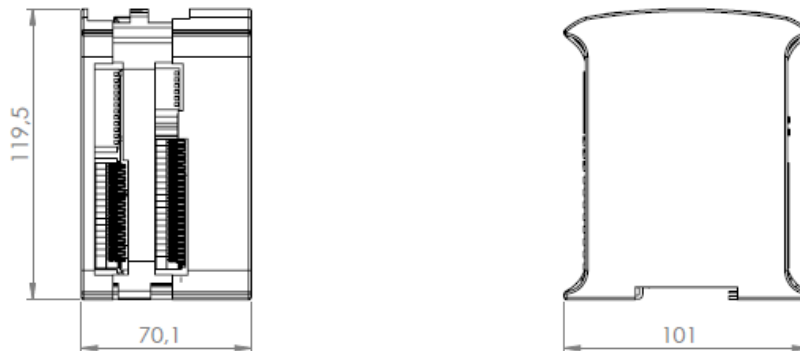



1.5. General Features

PLCARD21DP General Features		
MODEL TYPE	A+B Zone	
Input Voltage	12 to 24Vdc ---	Fuse protection (2.5A) Polarity protection
Input rated voltage	24 Vdc ---	
Rated Power	30 W	
I max.	1.5A	
Size	101x70.1x119.5	
Clock Speed	16MHz	
Flash Memory	256KB of which 8KB used by bootloader	
SRAM	8KB	
EEPROM	4KB	
Communications	I2C – Ethernet Port – USB – RS485 – RS232 -- SPI – (2x) Rx, Tx (Arduino pins)	Max232-Max485-W5500
USB consideration!	Only meant for uploading or debugging, not always connected as a serial in a project!	Cannot be working in a final application
An/Dig Input 10bit (0-10Vcc)	0 to 10Vac Input Impedance: 39K Separated PCB ground Rated Voltage: 10Vac 7 to 24Vdc I min: 2 to 12 mA Galvanic Isolation Rated Voltage: 24 Vdc ---	
Digital Isolated Input (24Vcc)	7 to 24Vdc I min: 2 to 12 mA Galvanic Isolation Rated Voltage: 24 Vdc ---	
* Interrupt isolated Input HS (24Vcc)	7 to 24Vdc I min: 2 to 12 mA Galvanic Isolation Rated Voltage: 24Vdc ---	
Analog Output 8bit (0-10Vcc)	0 to 10Vac I max: 20 mA Separated PCB ground Rated Voltage: 10Vac ---	
Digital Isolated Output (24Vcc)	5 to 24Vdc I max: 70 mA Galvanic Isolation Diode Protected for Relay Rated Voltage: 24Vdc ---	I _{max} 24Vdc: 410 mA
Digital Isolated Output Relay	220V Vdc I max: 5A Galvanic Isolation Diode protected for Relay ---	
PWM Isolated Output 8bit (24Vcc)	5 to 24Vdc I max: 70 mA Galvanic Isolation Diode Protected for Relay Rated Voltage: 24Vdc ---	
Expandability	I2C - 127 elements - Serial Port RS232/RS485	
* By using this type of signal can no longer use Digital signal (24Vdc)		

2. Technical Specifications:

2.1. General Specifications:

Item		PLCARD21DP Specifications
Power supply voltage	DC power supply	12 to 24Vdc 
Operating voltage range	DC power supply	11.4 to 25.4Vdc 
Power consumption	DC power supply	30W max.
External power supply	Power supply voltage	24Vdc 
	Power supply output capacity	700Ma
Insulation resistance		20MΩ min.at 500Vdc between the AC terminals and the protective earth terminal.
Dielectric strength		2.300 VAC at 50/60 Hz for one minute with a leakage current of 10mA max. Between all the external AC terminals and the protective ground terminal.
Shock resistance		80m/s ² in the X, Y and Z direction 2 times each.
Ambient temperature (operating)		0° to 60°C
Ambient humidity (operating)		10% to 90% (no condensation)
Ambient environment (operating)		With no corrosive gas
Ambient temperature (storage)		-20° to 60°C
Power supply holding time		2ms min.
Weight		378g max.

2.2. Performance Specification:







Arduino Board	ARDUINO MEGA 2560
Control method	Stored program method
I/O control method	Combination of the cyclic scan and immediate refresh processing methods.
Programming language	Arduino IDE. Based on wiring (Wiring is an Open Source electronics platform composed of a programming language. "similar to the C".
Microcontroller	ATmega2560
Flash Memory	256KB of which 8KB are used by the bootloader
Program capacity (SRAM)	8KB
EEPROM	4KB
Clock Speed	16MHz
Clock Speed	16MHz

2.3. Symbolology

Table that includes all the symbolology that is used in the serigraph of the M-Duino PLC Arduino Ethernet

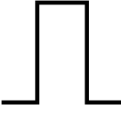
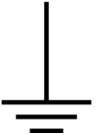
21

I/Os Analog/Digital PLUS:

Symbol	Standard No. / Standard Title	Standard Reference No. / Symbol Title	Symbol Meaning
	IEC 60417 / Graphical symbols for use on equipment	5031 / Direct Current	Indicates that the equipment is suitable for direct current only; to identify relevant terminals
	IEC 60417 / Graphical symbols for use on equipment	5032 / Alternating Current	Indicates that the equipment is suitable for alternating current only; to identify relevant terminals
	IEC 60417 / Graphical symbols for use on equipment	5130 / Pulse General	To identify the control by which a pulse is started.
	IEC 60417 / Graphical symbols for use on equipment	5017 / Earth, Ground	To identify an earth (ground) terminal in cases where neither the symbol 5018 nor 5019 is explicitly required.
	IEC 60417 / Graphical symbols for use on equipment	5115 / Signal lamp	To identify the switch by means of which the signal lamp(s) is (are) switched on or off.
	2004/108/EC / Electromagnetic Compatibility	CE Marking	CE marking indicates that a product complies with applicable European Union regulations
	ISO 7000/ Graphical symbols for use on equipment	0434B / Warning symbol	Indicates a potentially hazardous situation which, if not avoided, could result in death or serious injury
	ISO 7000/ Graphical symbols for use on equipment	5036 / Dangerous Voltage	To indicate hazards arising from dangerous voltages

3. Precautions

Read this manual before attempting to use the L-com PLCARD21DP PLC and follow its descriptions for reference during operation.

3.1. Arduino Board

The L-com PLCARD21DP includes an Arduino Mega Board as controller.

3.2. Intended Audience

This manual is intended for technicians who must have knowledge on electrical systems.

3.3. General Precautions

The user must operate L-com PLCARD21DP according to the performance specifications described in this manual. Before using L-com PLCARD21DP under different conditions from what has been specified in this manual or integrating L-com PLCARD21DP to nuclear control systems, railroad systems, aviation systems, vehicles, combustion systems, medical equipment, amusement machines, safety equipment and other systems, machines, and equipment that may have a serious influence on lives and property if used improperly, consult your LCOM representative. Ensure that the rating and performance characteristics of M-Duino are sufficient for the systems, machines, and equipment, and be sure to provide the systems, machines, and equipment double safety mechanisms. This manual provides information for programming and operating the M-Duino.

4. Software interface

LCOM PLC are programmed using Arduino IDE, which is a software based on the C language. They can also be programmed using directly C but it is much easier working with Arduino IDE as it provides lots of libraries that help in the programming. LCOM provides boards for programming the PLCs much easier. Basically, there is no need to define the pins and if said pins are inputs or outputs. Everything is set up automatically if using the boards.

To install LCOM boards, these are the steps that must be followed.

Requirements:

Arduino IDE 1.8.0 or above (better to always have the latest version).

Also, there are some libraries can be found in GitHub.com.

5. How to connect PLC Arduino to PC

- Connect USB port from PLC to PLC



NOTE:

- L-com PLCARD21DP uses USB-B cable.
- Open Arduino IDE interface:
- Select Industrial Shields boards -> M-Duino Family

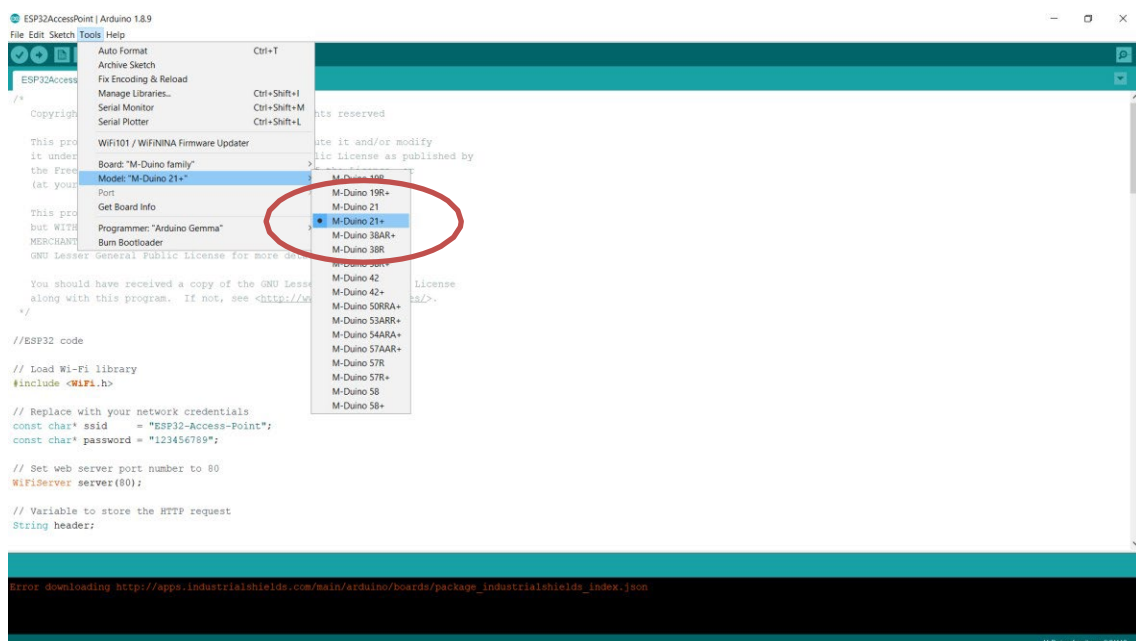

- Select the correct M-Duino Board (M-Duino 21+).

- Select correct port.

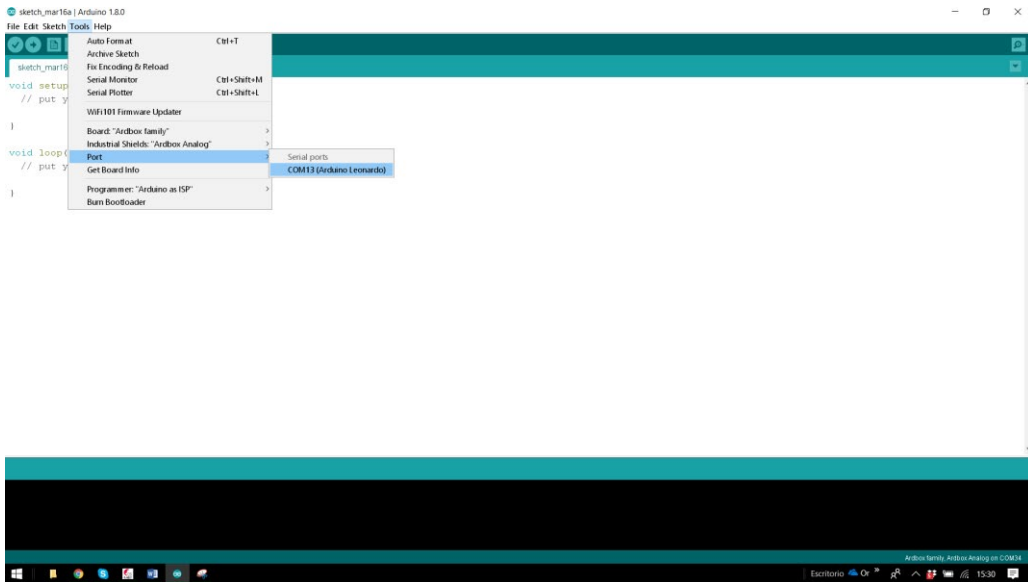

6. How to connect PLC to power supply

- M-Duino 21 I/Os PLUS PLC is 12-24Vdc supplied. **IMPORTANT: The polarity IS NOT REVERSABLE!**
- Make sure that the live and GND connector of the power supply match the PLC.
- Make sure that the power supply mains output is not higher than 24Vdc.

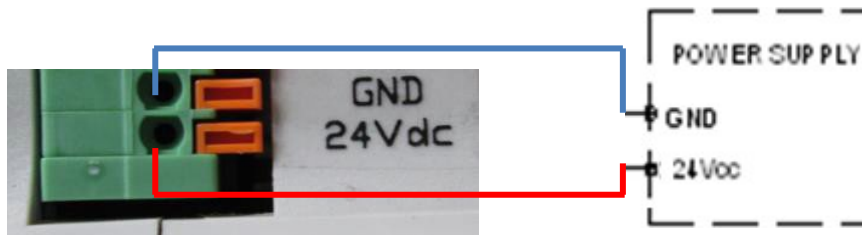

- Suggested power suppliers

Compact DIN rail power supply. Assembled on 35mm

DIN Rail:

-12Vdc / 24Vdc

-2.5A

-30W

LCOM power supplies provide parallel operation, overvoltage protection, and overcurrent protection. There is an LED indicator for power status, the power supply is certified according to UL.



The standard, Part 1 of IEC 61010, sets the general safety requirements for the following types of electrical devices and their accessories, regardless of where use of the device is intended.

The equipment must be powered from an external power source in accordance with IEC 61010-1, whose output is MBTS and is limited in power according to section 9.4 of IEC 61010- 1.

WARNING: Once the equipment is installed inside an electrical cabinet, the MTBS cables of the equipment must be separated from the dangerous voltage cables.

7. Arduino PLC Family Pinout

7.1. A Zone connection

Base (common unit)		
A Zone		
M-Duino Connector	Arduino Pin	Function
SCL	21	I2C/SS
SDA	20	I2C/SS
RX0	1	RX0/SS
TX0	0	TX0/SS
RX1	19	RX1/SS
TX1	18	TX1/SS
TX	16	RX2(serial 2)
RX	17	TX2(serial 2)
Z-	-	RS485
Y+	-	RS485
B-	-	RS485
A+	-	RS485
PIN3	3	Arduino Pin
50 SO	50	SPI
51 SI	51	SPI
52 SCK	52	SPI
Reset	Reset	SPI
Vin5	Vin5	5V
PIN2	2	Arduino Pin
GND	-	Gnd
GND	-	Gnd
24Vdc	-	Power Supply

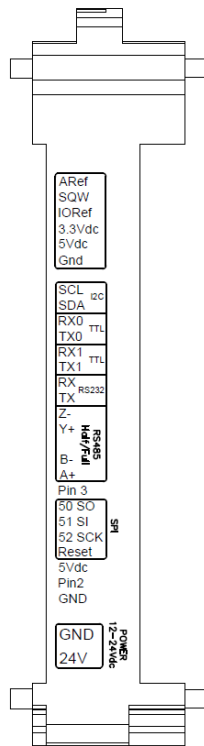

Configuration Switch* (see section 8 for configuring the communications. Enabling communications disables some I/Os)

Communication Pins

Power supply connectors (24Vdc – GND)

SS: Chip Select pins. These pins can act as TTL, so they can work for the Chip Select pin of any device.

Base (common unit)		
A Zone		
M-Duino Connector	Arduino Pin	Function
AREF	AREF	Arduino PIN
IOREF	IOREF	Arduino PIN
F2	2	Arduino PIN
IOREF	IOREF	Arduino PIN
F1	1	Arduino PIN
7Vdc	7Vdc	-
GND	GND	GND
3.3Vdc	3.3Vdc	Arduino PIN
GND	GND	GND
5Vdc	5Vdc	-
GND	GND	GND

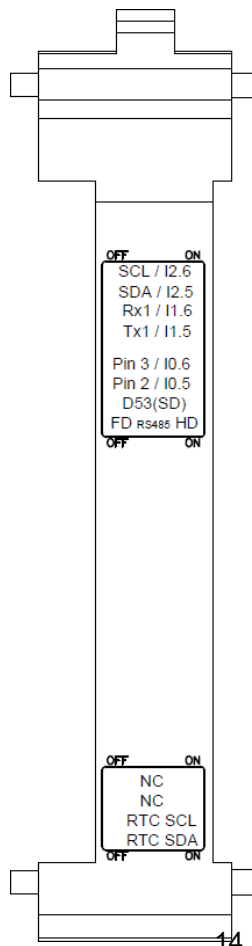

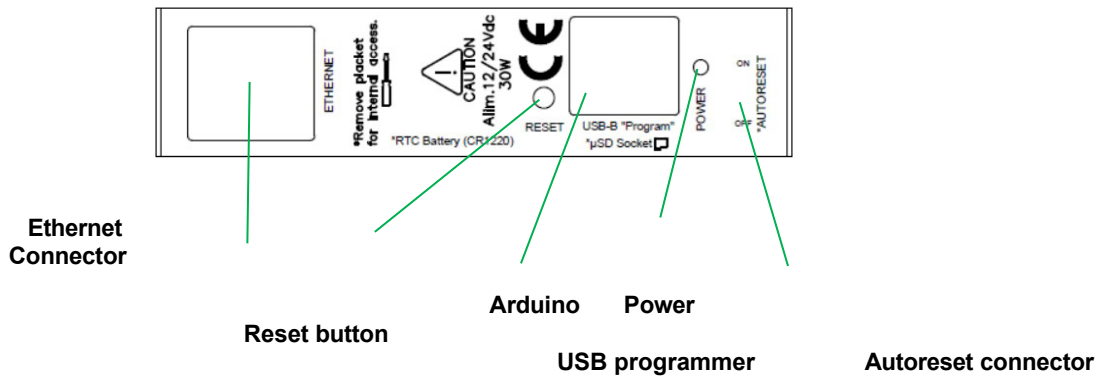

**NOTE: Autoreset. Arduino mega has auto reset when using serial communication code. Set switch to OFF when using serial communication. When uploading code to Arduino Mega set switch to ON.*

7.2. B Zone (Analog Shield)

B Zone		
M-Duino Connector	Arduino Pin	Function
I0.12	59	Analog/ Digital In
I0.11	58	Analog/ Digital In
I0.10	57	Analog/ Digital In
I0.9	56	Analog/ Digital In
I0.8	55	Analog/ Digital In
I0.7	54	Analog/ Digital In
(-)I0.6/INT1	-	GND I0.6
I0.6/INT1 ¹	3	Interrupt 1 In
(-)I0.5/INT0	-	GND I0.5
I0.5/INT0 ¹	2	Interrupt 0 In
(-)I0.4	-	GND I0.4
I0.4	26	Digital Input
(-)I0.3	-	GND I0.3
I0.3	25	Digital Input
(-)I0.2	-	GND I0.2
I0.2	24	Digital Input
(-)I0.1	-	GND I0.1
I0.1	23	Digital Input
(-)I0.0	-	GND I0.0
I0.0	22	Digital Input

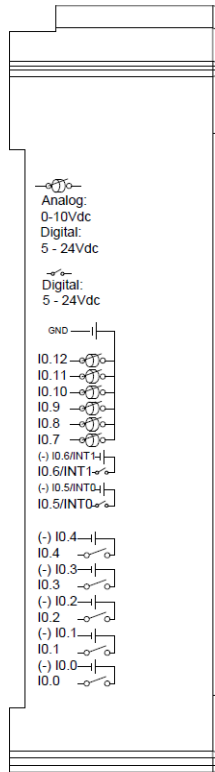

Analog/Digital

Inputs Interrupt

Inputs (isolated)

Digital Inputs (isolated)

Top Zone

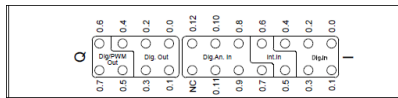

Led indicator
I/Os state

B Zone		
M-Duino Connector	Arduino Pin	Function
GND	GND	GND
A0.7 ¹	6	Analog Out
A0.6 ¹	5	Analog Out
A0.5 ¹	4	Analog Out
Q/Vdc	-	External Isolated Out Vdc
COM(-)	-	External Isolated Out GND
Q0.7 ¹	6	Digital/PWM Out
Q0.6 ¹	5	Digital/PWM Out
Q0.5 ¹	4	Digital/PWM Out
Q0.4	40	Digital Out
Q0.3	39	Digital Out
Q0.2	38	Digital Out
Q0.1	37	Digital Out
Q0.0	36	Digital Out

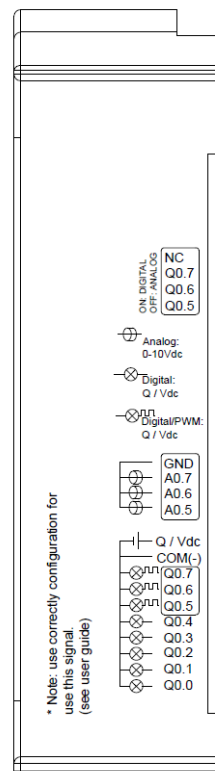

Configuration Switch*
(see section 8 to select the correct configuration for outputs).

Analog Outputs

Voltage Supply/Reference for
Digital/PWM Outputs
(isolated)

PWM/Digital Outputs

¹ See section 8 to select suitable switch configuration for enable these connections.

8. Switch Configuration

8.1.A Zone: Communications

Switch	ON	OFF
D ZONE		
SCL/I2.6	NC	SCL
SDA/I2.5	NC	SDA
C ZONE		
RX1/I1.6	NC	RX1
TX1/I1.5	NC	TX1
B ZONE		
Pin 3/I0.6	I0.6	Pin 3
Pin 2/I0.5	I0.5	Pin 2
uSD & RS-485		
D53(SD)	NC	SD
FD RS-485 HD	HD	FD

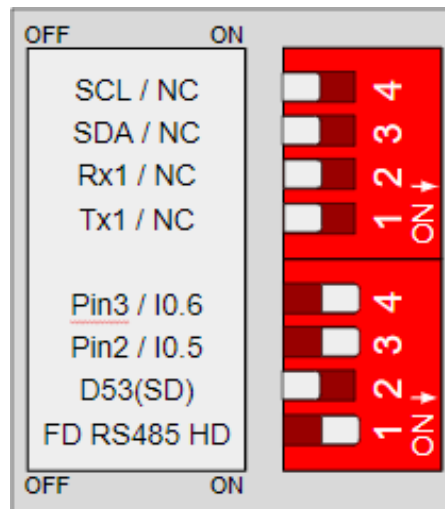

4. SCL/NC: **Always at OFF Position!** Switch has to be OFF position to enable SCL, **never ON** because in this position is NC (Not Connected).
3. SDA/NC: **Always at OFF Position!** Switch has to be OFF position to enable SDA, **never ON** because in this position is NC (Not Connected).
2. RX1/NC: **Always at OFF Position!** Switch has to be OFF position to enable RX1 **never ON** because in this position is NC (Not Connected).
1. TX1/NC: **Always at OFF Position!** Switch has to be OFF position to enable TX1, **never ON** because in this position is NC (Not Connected).

4. Pin 3/I0.6: Choosing between Pin 3 or the input I0.6. If this switch is ON, it enables the I0.6 input and disables the Pin 3. If this switch is OFF, it enables Pin 3 and disables I0.6.

3. Pin 2/I0.5: Choosing between Pin 2 or the input I0.5. If this switch is ON, it enables the I0.5 input and disables the Pin 2. If this switch is OFF, it enables Pin 2 and disables I0.5.

2. D53 (SD): **Always at OFF Position!** Switch has to be OFF position to enable the Chip Select of the microSD card, **never ON** because in this position is NC (Not Connected).

1. FD RS-485 HD: Choosing between FD or HF. If this switch is ON, it enables the Half Duplex (HD) option and disables the FD. If this switch is OFF, it enables Full Duplex (FD) and disables HD.

LEFT ZONE		
SWITCH	ON	OFF
NC	-	-
NC	-	-
RTC SCL	RTC	-
RTC SDA	RTC	-



1. RTC SDA: This switch enables the communication to communicate with the RTC using I2C. Having this switch in ON mode it activates this communication, whereas if it is in OFF mode it disables the I2C to reach the RTC.
2. RTC SCL: This switch enables the communication to communicate with the RTC using I2C. Having this switch in ON mode it activates this communication, whereas if it is in OFF mode it disables the I2C to reach the RTC.
3. NC: Not connected. This switch is not connected to anything, it doesn't matter if it is in ON mode or OFF mode.
4. NC: Not connected. This switch is not connected to anything, it doesn't matter if it is in ON mode or OFF mode.

8.2. B, C & D Zone Switches

B ZONE		
SWITCH	ON	OFF
NC	-	-
Q0.7	Q0.7	A0.7
Q0.6	Q0.6	A0.6
Q0.5	Q0.5	A0.5

C ZONE		
SWITCH	ON	OFF
NC	-	-
Q1.7	Q1.7	A1.7
Q1.6	Q1.6	A1.6
Q1.5	Q1.5	A1.5

D ZONE		
SWITCH	ON	OFF
NC	-	-
Q2.7	-	-
Q2.6	Q2.6	A2.6
Q2.5	Q2.5	A2.5



For the Analog Shield if a switch is set to ON, it can only act as Digital Output. If it is set to OFF it can only act as an Analog Output.

If it is desired to use a Digital Output the pin must be set to ON and the pin that will provide this digital output is represented with QX.X, being X any number of the tables above.

If it is desired to use an Analog Output the pin must be set to OFF and the pin that will provide this analog output is represented with AX.X, being X any number of the tables above.

For the Relay Shield if a switch is set to ON, it can only act as Digital Output. If it is set to OFF it can only act as an Analog Output.

If it is desired to use a Digital Output the pin must be set to ON and the pin that will provide this digital output is

represented with QX.X, being X any number of the tables above.

If it is desired to use an Analog Output the pin must be set to OFF and the pin that will provide this analog output is represented with AX.X, being X any number of the tables above.

9. Arduino I/Os 5V pins

The L-com PLCARD21DP has some Mega board pins available. These pins can be programmed according to Arduino features such as I/Os operating at 5V or any additional features present in the pins (for example I2C communication in pins SCL and SDA). As these pins are directly connected to the Arduino Mega board they are not as well protected as the normal inputs. These pins are mainly meant to be used as prototyping.

The Arduino board available pins are summarized in the table below. To access some of these pins the configuration switch must be set to OFF position (see section 8) and some extra considerations must be taken into consideration when using these pins.

M-Duino terminal	Arduino pin	Enable Arduino pin
SCL	21	Communication switch: OFF
SDA	20	Communication switch OFF
RX0	0	
TX0	1	
RX1	19	Communication switch: OFF
TX1	18	Communication switch: OFF
MISO	50	
MOSI	51	
SCK	52	
Pin 3	3	Communication switch: OFF
Pin 2	2	Communication switch: OFF

***IMPORTANT:** Do not connect the terminals in the chart above to voltages higher than 5V. These terminals provide direct access to the Mega board.

Apart from the switch configuration there are some special conditions depending on these 5V. Now it is going to be shown the considerations to operate with these pins.

9.1. I2C pins – SDA/SCL

The I2C protocol is meant to work in a pull-up configuration. A pull-up configuration means that when the pin is at rest (nothing connected to it) it always reads a HIGH value. In this case it reads 5V when nothing is connected. The pull-up configuration is established by default in these pins.

If it is meant to work them as a GPIO at 5V, it has to be considered that they are pull-up inputs.

***IMPORTANT:** I2.5 & I2.6 are not pull-up inputs although they are referred to the I2C pins (switch configuration). There is a "reverse pull-up circuit" that is established in order to have the same behavior as the other inputs.

9.2. Serial 0 – RX0/TX0

The Serial0 protocol can work also as a 5V pin. These pins should be used ultimately, only in case that all the 5V pins are already performing a function. This is because they are shared with the USB interface. If using these pins, the USB communication cannot be working at the same time. When the PLC is not installed, the USB communication is normally required for debugging, uploading, and intercommunicating with the Ethernet controller. If both interfaces are used at the same time, the Arduino board will get blocked.

These pins are not established with a pull-up or a pull-down configuration. The state of these pins is unknown. If these pins must be used, they require a pull-up or a pull-down configuration. The Arduino board allows the pins to be set in a pull-up configuration. An external pull-up or pull-down circuit must be established to correctly work with these pins.

9.3. Serial 1 – RX1/TX1

These pins are only referred to the inputs I1.5/I1.6. If the switch configuration is in OFF position the pins RX1/TX1 will be available. If not using the Serial 1 interface these pins can work as digital, either input or output.

These pins are not established with a pull-up or a pull-down configuration. The state of these pins is unknown. If these pins must be used, they require a pull-up or a pull-down configuration. The Arduino board allows the pins to be set in a pull-up configuration. If not, it must be established an external pull-up or pull-down circuit in order to correctly work with these pins.

9.4. SPI – MISO/MOSI/SCK

These pins can only work as 5V pins if the Ethernet protocol is not going to be used. As the Ethernet protocol uses the SPI to communicate with the Arduino board, both behaviors cannot happen at the same time as the Ethernet would not work.

These pins are not established with a pull-up or a pull-down configuration. The state of these pins is unknown. If these pins must be used, they require a pull-up or a pull-down configuration. The Arduino board allows the pins to be set in a pull-up configuration. If not it must be established an external pull-up or pull-down circuit in order to correctly work with these pins.

9.5. Pin 2/Pin 3

These pins only refer to the inputs I0.5/I0.6. If the switch configuration is in OFF position the pins Pin 2/Pin 3 will be available.

These pins are not established with a pull-up or a pull-down configuration. The state of these pins is unknown. If these pins must be used, they require a pull-up or a pull-down configuration. The Arduino board allows the pins to be set in a pull-up configuration. If not, it must be established an external pull-up or pull-down circuit to correctly work with these pins.

10. A Zone Features: Communications & RTC & uSD

10.1. RS-232

The Arduino Mega function code to access the RS-232 port in the M-Duino is Serial2 (pins 16 and 17 of the Arduino Mega).

For the RS-232 communication protocol there isn't any switch that affects it. So, the configuration of the switches to implement a RS-232 communication does not matter.

When using the boards of LCOM, there is a library that simplifies the RS-232 implementation.

10.2. RS-485

For RS485 communication protocol the defined Arduino Mega pins are shown in the chart below.

Function	Arduino Pin
DI	14
RO	15
RE	11
DE	46

For the RS-485 communication protocol there is only one switch that affects this communication. The RS-485 protocol will be always enabled, the only switch that affects is the one called "FD rs-485 HD" (See Section 8). This switch makes the choosing between RS-485 Half Duplex or RS-485 Full Duplex (RS-422).

Using the boards of LCOM, there is a library that simplifies the RS-485 implementation.

10.3. I2C

I2C communication **DOES NOT REQUIRE** a pull-up resistor for the M-Duino 21 I/Os PLUS. The pull-up resistor is already implemented in the PCB.

I2C communication is configured by switches, so the switches must be configured in order to enable the I2C communication.

Switch	ON	OFF
D ZONE		
SCL/I2.6	I2.6	SCL
SDA/I2.5	I2.5	SDA

To enable I2C the switches SCL/I2.6 & SDA/I2.5 must be set to OFF mode. In this mode the inputs are totally disabled and the I2C is now enabled.

LCOM does not provide any library to implement the I2C as it can be used in the standard library of Arduino called Wire.

10.4. SPI

The M-Duino pins used for the SPI bus are summarized in the table below. For SPI bus MISO, MOSI and CLOCK pins are common to all the connected devices to the M-Duino, conversely, each of the connected devices will have a single and dedicated SS pin.

Function	M-Duino connection	Mega board pin
MISO	50 S0	50

MOSI	51 SI	51
CLOCK	52 SCK	52
Reset	Reset	Reset
SS	SCL/SDA/RX0/TX0/RX1/TX1/RX3/TX3/Pin2/Pin3	21/20/1/0/19/18/15/14/2/3

Check the switch configuration at section 8 to enable SS pins.

10.5. TTL

M-Duino has two TTL ports, RX0/TX0, RX1/TX1. TTL0 is accessed with the function Serial (pins 0 and 1 of the Arduino Mega). TTL1 is accessed with the function Serial1 (pins 18 and 19 of the Arduino Mega).

To use the TTL pins the configuration of the switches have to be the following one:

Switch	Analog Shield	
	ON	OFF
C ZONE		
RX1/I1.6	I1.6	RX1
TX1/I1.5	I1.5	TX1

If the switches RX1/I1.6(I1.1) & TX1/I1.5(I1.0) are in OFF mode, the RX1/TX1 will be enabled. To use TTL3 these switches must be in OFF mode.

10.6. Ethernet

M-Duino Ethernet port controller is based on w5500 IC, which is the compatible IC compatible with Arduino Ethernet2 Shield libraries. All Ethernet shield Arduino libraries are compatible with the M-Duino. In the M-Duino, W5500 IC communicates to the Mega board via SPI bus (SS Arduino Mega pin 10).

10.7. RTC

M-Duino RTC Module is based on the DS1307 Chip. This chip works with the I2C protocol communication, so it is required to have enabled the I2C protocol.

4 switches must be configured in order to enable the RTC features:

LEFT ZONE		
SWITCH	ON	OFF
NC	-	-
NC	-	-
RTC SCL	RTC	-
RTC SDA	RTC	-

RTC SCL & RTC SDA must be set to ON mode to enable the I2C wires to the RTC. If they are in OFF mode, the Arduino won't communicate with the RTC.

Switch		
	ON	OFF
SCL/I2.6	I2.6	SCL
SDA/I2.5	I2.5	SDA

I2C (SCL, SDA pins) must be enabled in order to communicate with the RTC. See section 11 I2C to enable it.

When using the boards of LCOM, there is a library that simplifies the RTC implementation called RTC.

10.8. uSD

The micro SD uses the SPI communication to interact with the Arduino Mega. The SPI protocol is always enabled, as there are no switches that configure it. However, there is a switch that must be placed to ON mode to communicate with the uSD:

D53(SD): If this Switch is OFF, it enables the Chip Select of the microSD socket and disables Q2.0. If this switch is ON, it enables the Q2.0 output. If the switch is in ON mode the microSD can't be used.

The uSD socket is found in the TOP part of the communication Shields, so in the frontal part of the PLC, it is required to open the plastic found in the frontal part and the socket is located under the supply of the Arduino.

LEFT ZONE		
Switch		
	ON	OFF
uSD		
D53(SD)	Q2.0	D53(SD)

When using the boards of LCOM, there is a library that simplifies the uSD implementation called SD. It is the same as the Arduino library, with the only modification of using pin 53 to select the Chip Select of the uSD chip.



Verify that the CPU is not actively running a process before inserting the memory card.

Inserting a memory card will cause the CPU to go to STOP mode, which could affect the operation of an online process or machine. Unexpected operation of a process or machine could result in death or injury to personnel and/or property damage. Before inserting a memory card, always ensure that the CPU is offline and in a safe state.



Vérifiez que le processeur n'exécute pas activement un processus avant d'insérer la carte mémoire.

Si vous insérez une carte mémoire, la CPU passe en mode STOP, ce qui peut affecter le fonctionnement d'un processus ou d'une machine en ligne. Le fonctionnement inattendu d'un processus ou d'une machine peut entraîner la mort ou des blessures corporelles et / ou des dégâts matériels. Avant d'insérer une carte mémoire, assurez-vous toujours que la CPU est hors ligne et en sécurité.

11. Instructions for interconnection between LCOM controllers

11.1. RS-232 Communication:

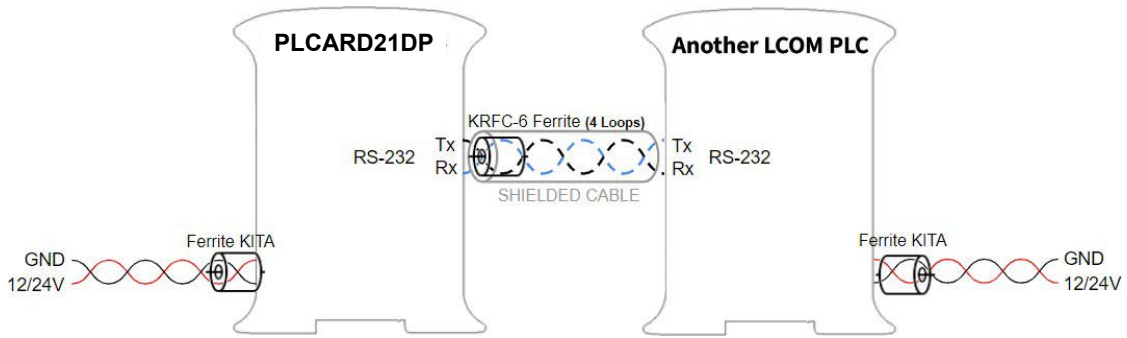

11.2. RS-485 Communication

11.2.1. Half Duplex

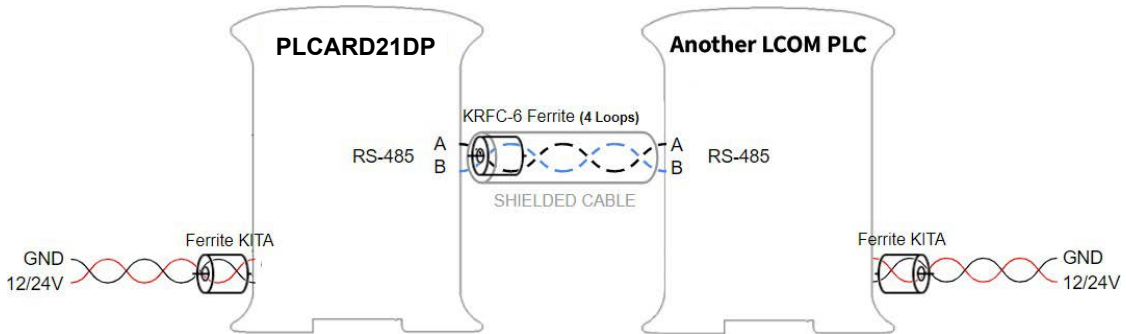

11.2.2. Full Duplex

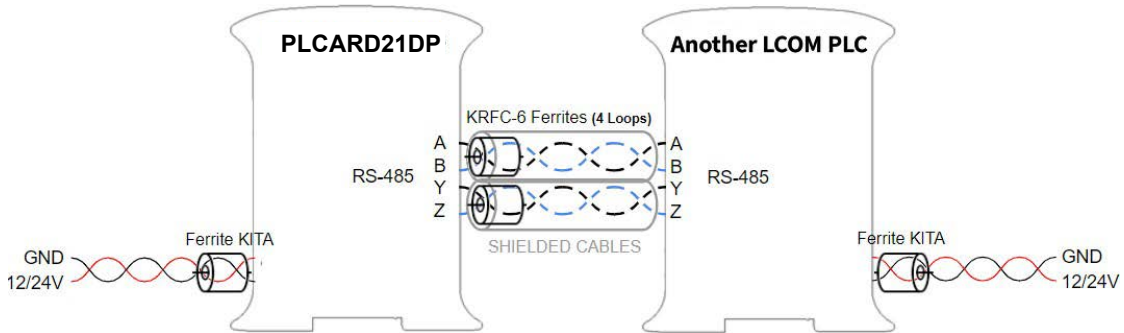

11.3. Ethernet

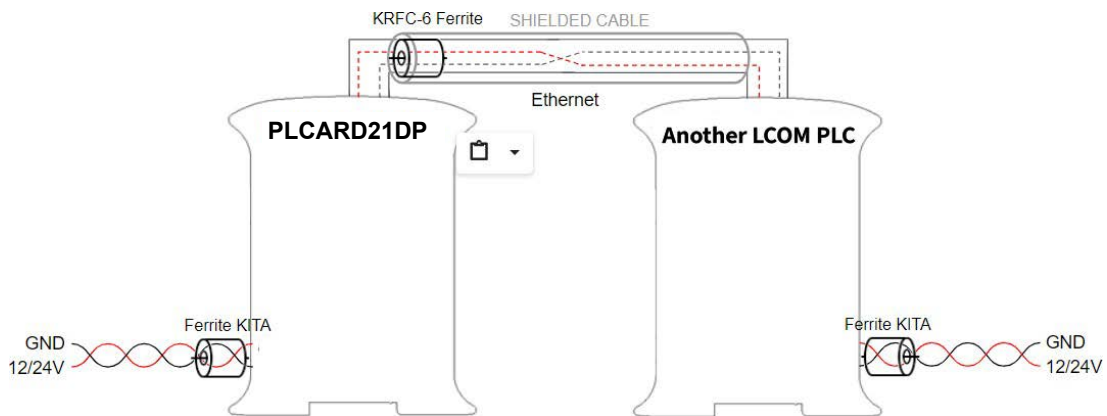

For an Ethernet communication between LCOM equipment a **SFTP CAT-6 Ethernet crossover cable** must be used.

12. I/O technical details:

Digital Output Waveform:

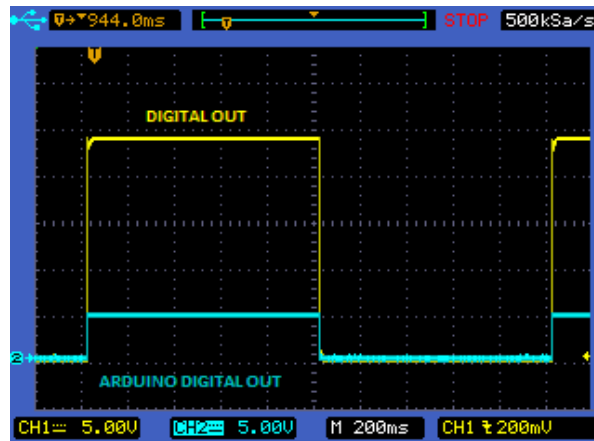

Digital Out-put Turn-off:

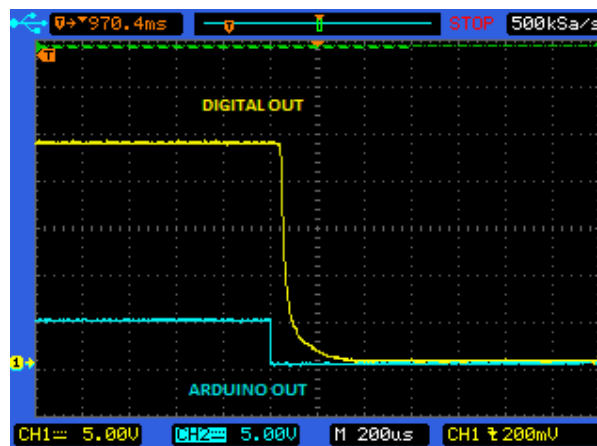

PWM Waveform:

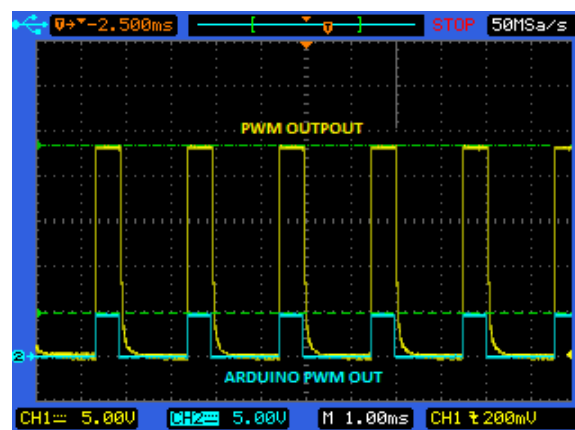

Analog Out Turn On:

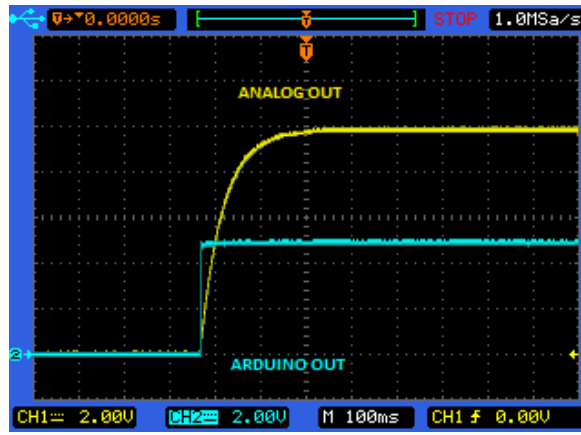

Analog Out Turn-Off:

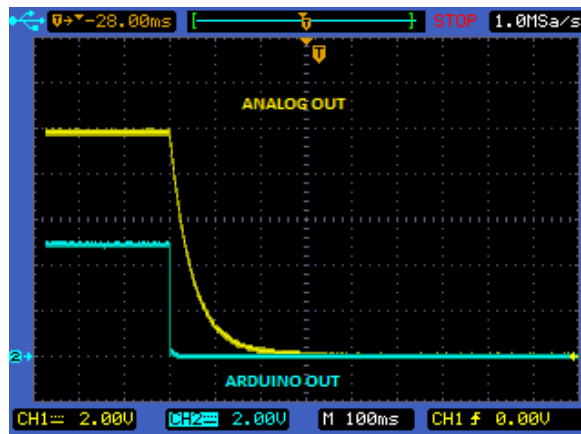

Analog /Digital input Turn-on:

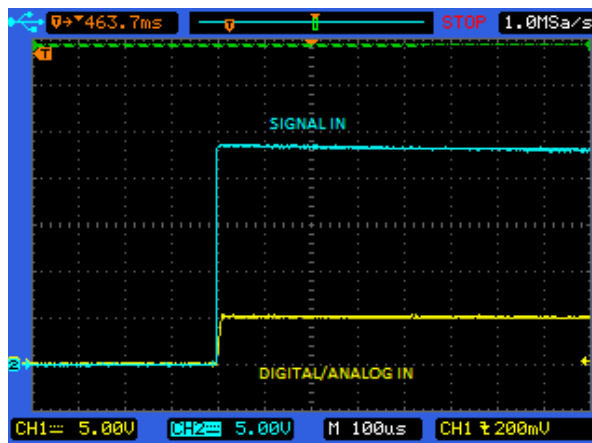

13. Typical Connections

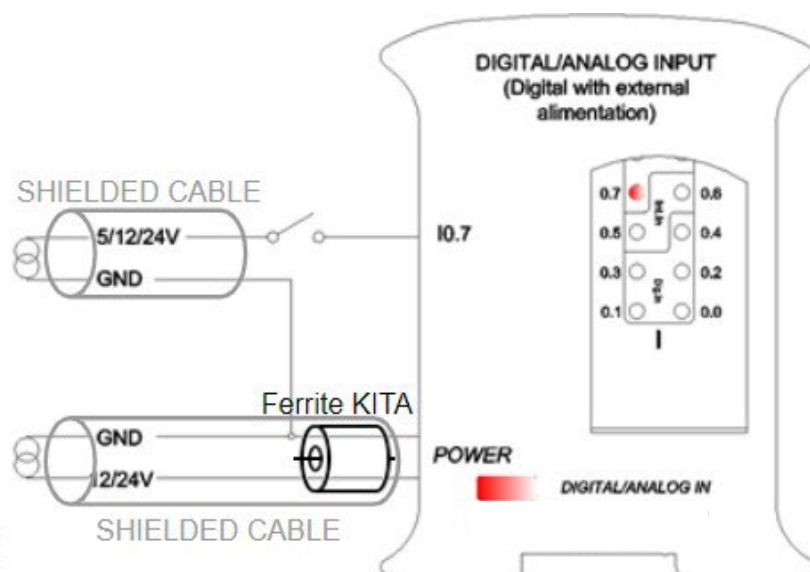
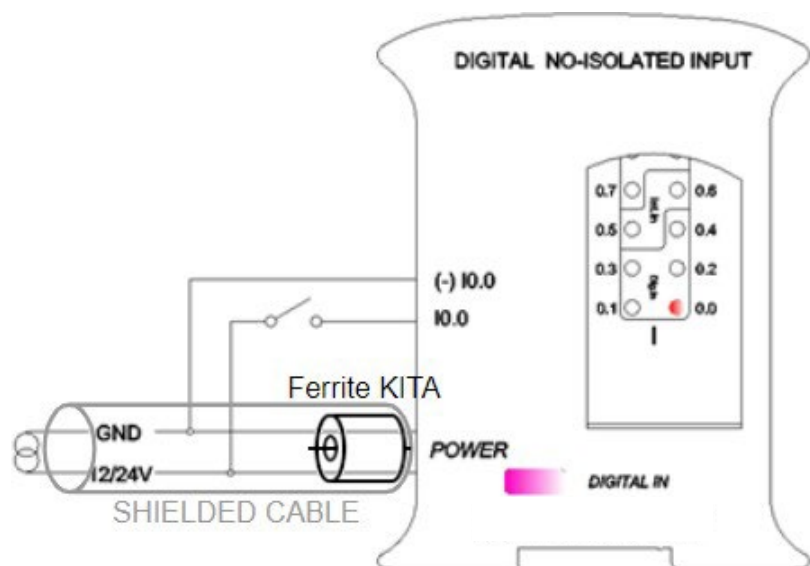
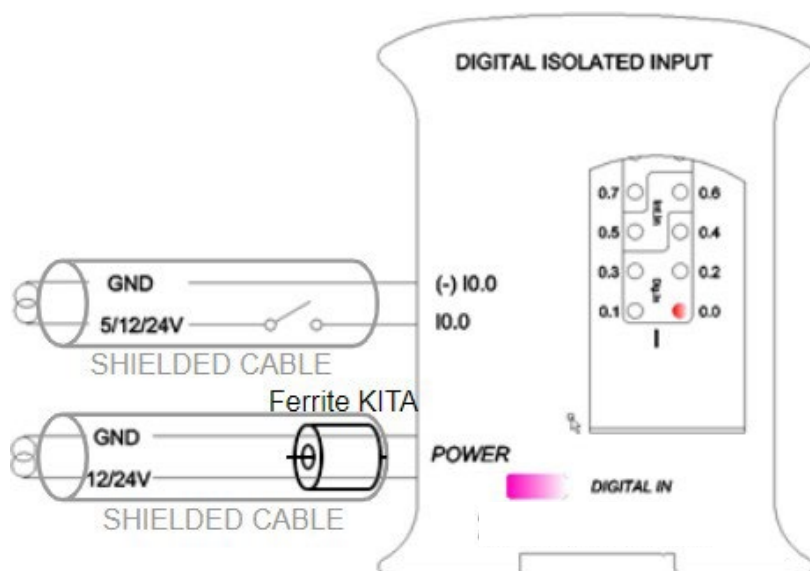

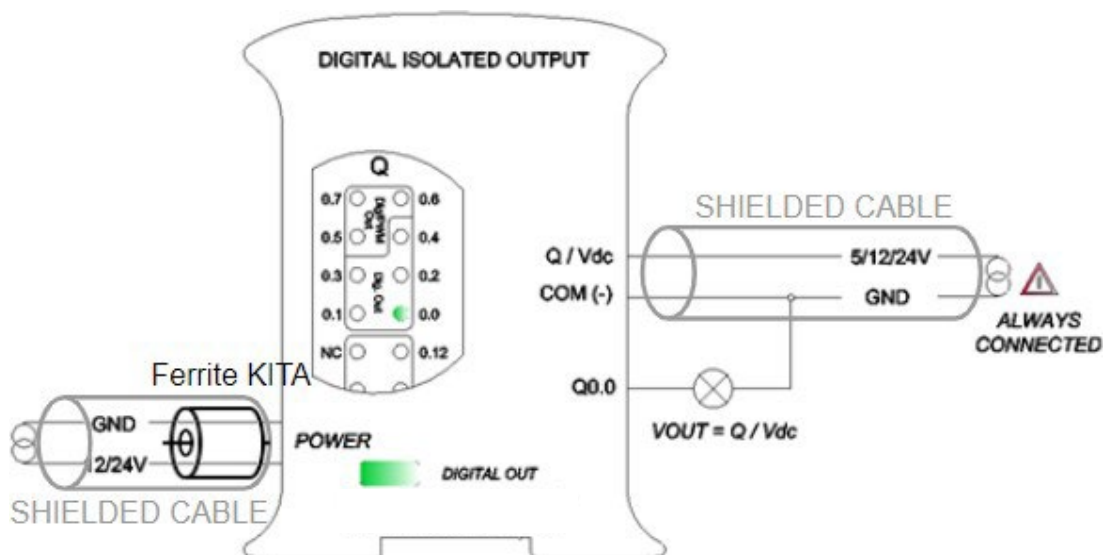
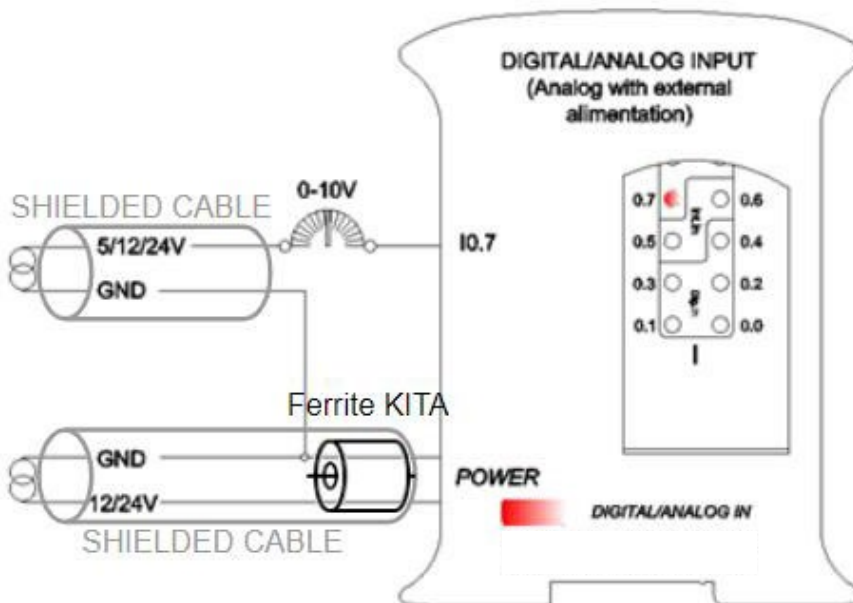
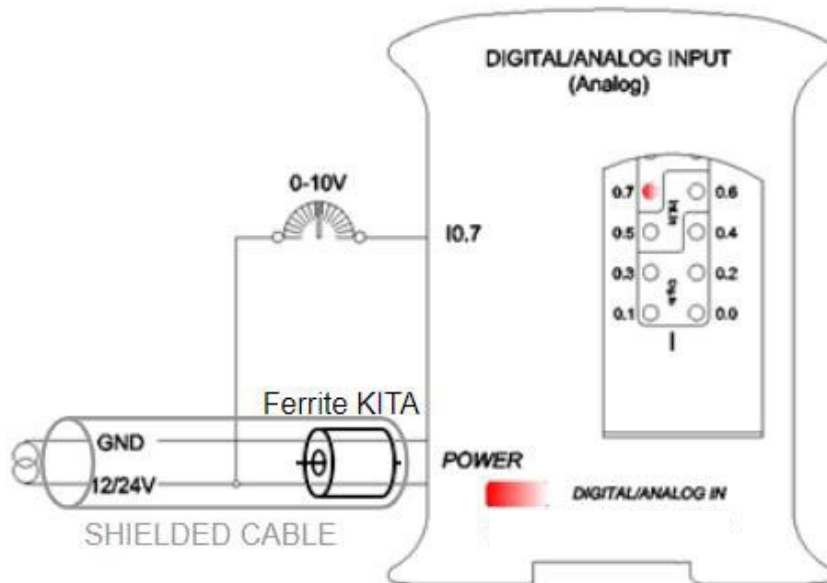

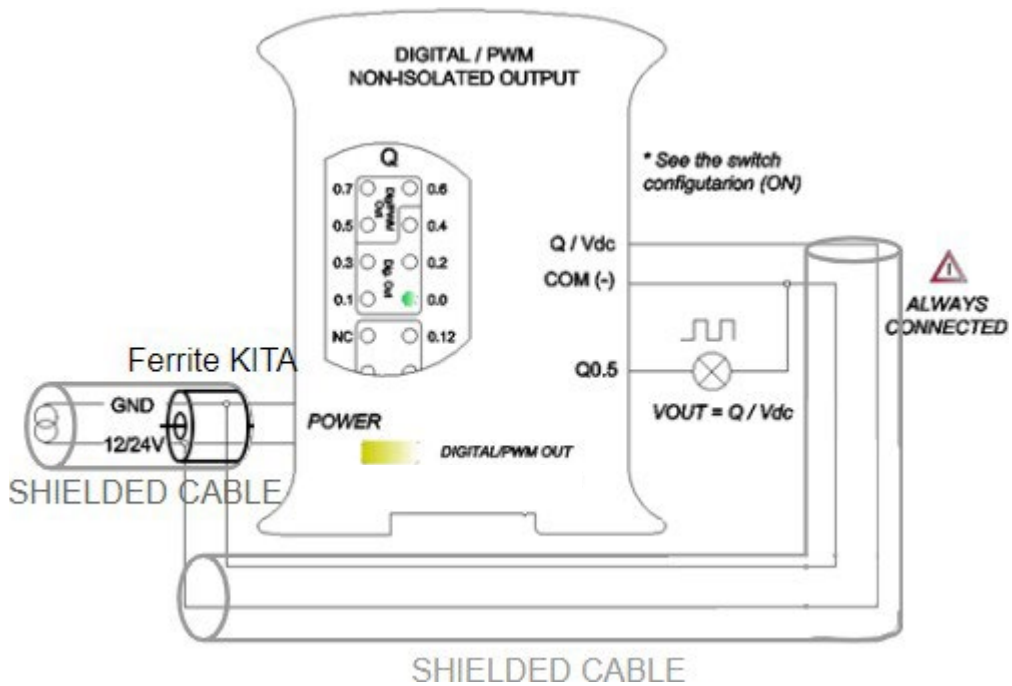
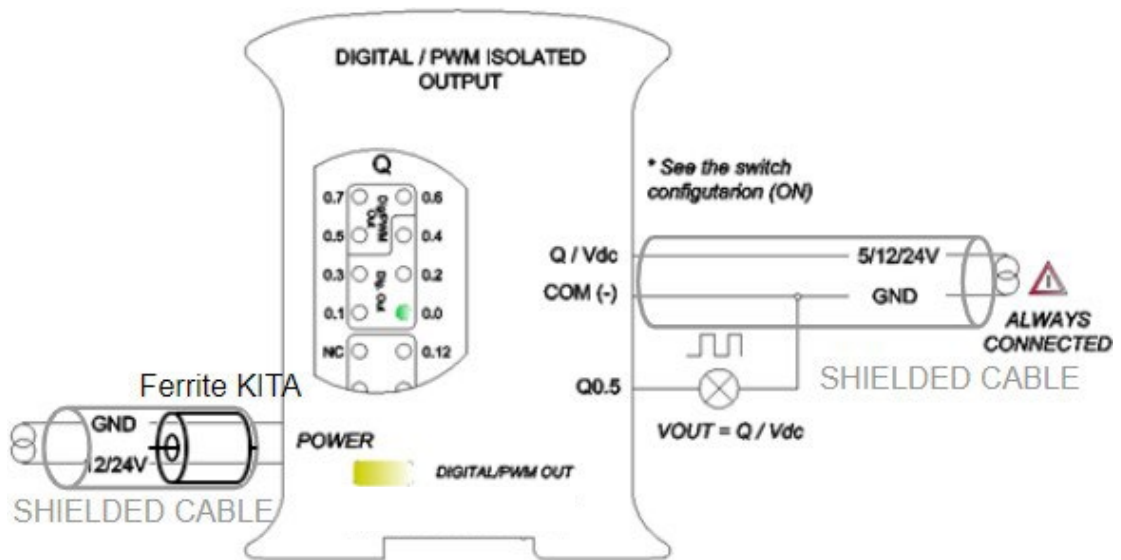
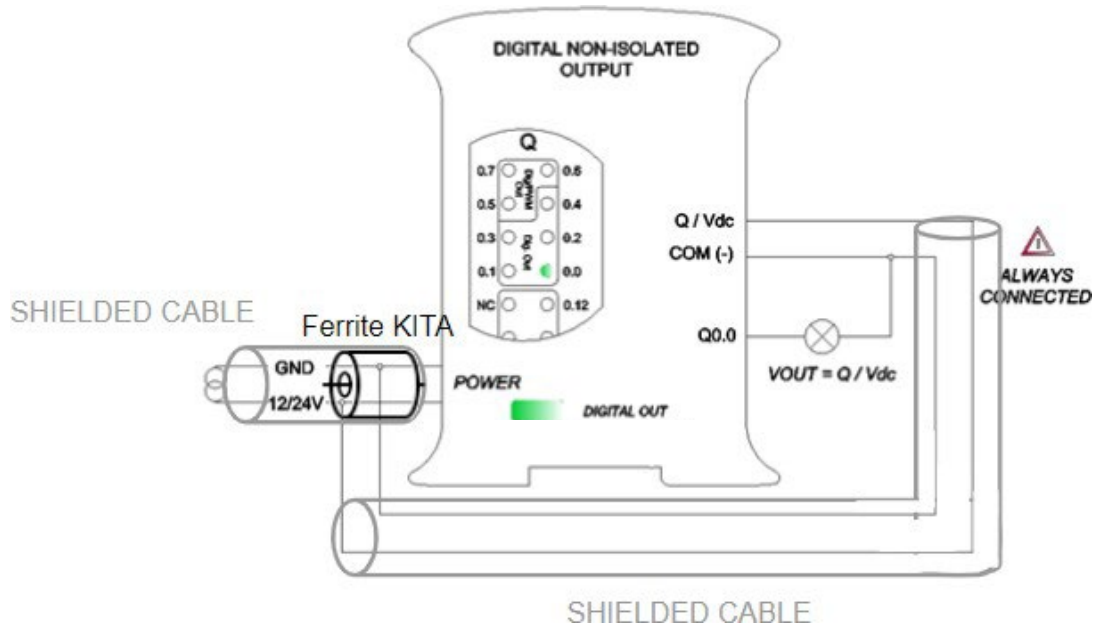

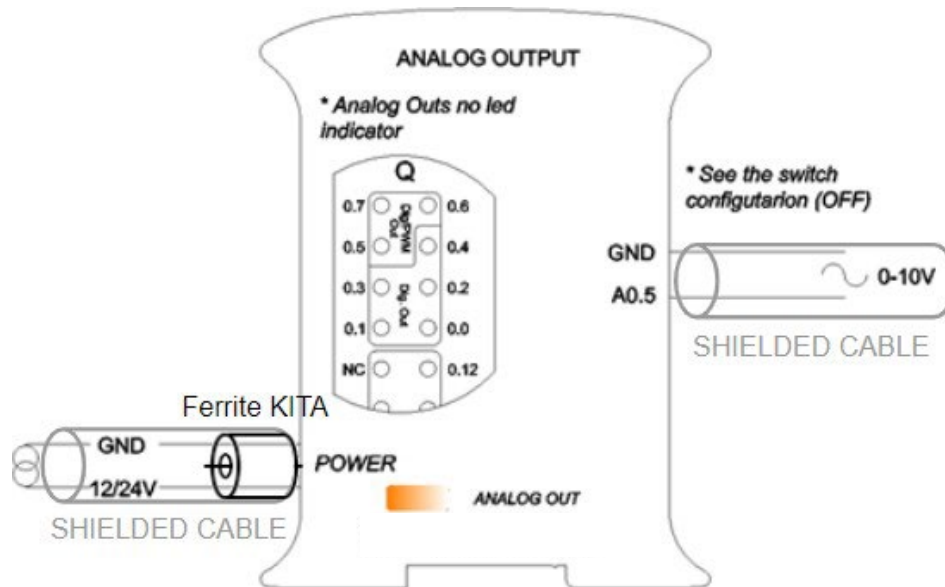

14. Connector details:

The connector inside the PLCs that mounts on the PCB is MC 0,5/10-G-2,5 THT – 1963502 from Phoenix contact. [MC0,5/10-G-2,5THT](#)

For I/O and power supply there is a FK-MC 0,5/10-ST-2,5 - 1881406 connector from Phoenix contact. [FK-MC 0,5/10-ST-2,5](#)

Connection details:

Article reference	MC 0,5/10-G-2,5 THT
Height	8,1mm
Pitch	2,5mm
Dimension	22,5mm
Pin dimensions	0,8x0,8mm
Pin spacing	2,50mm



Article reference	FK-MC 0,5/10-ST-2,5
Rigid conduit section min.	0,14 mm ²
Rigid conduit section max.	0,5 mm ²
Flexible conduit section min.	0,14 mm ²
Flexible conduit section max.	0,5 mm ²
Conduit section AWG/kcmil min.	26
Conduit section AWG/kcmil max.	20

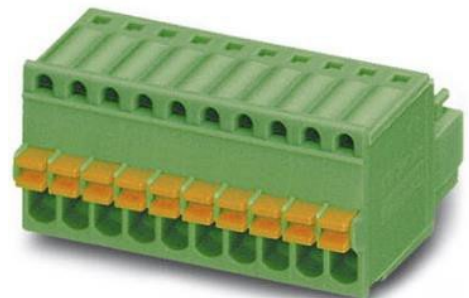

15. Mechanical Characteristics

- Dimension PLCARD21DP:

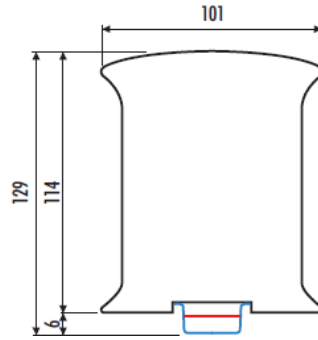

- DIN Rail mounting

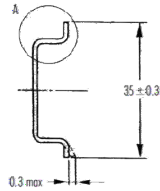
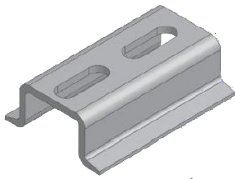

Profilato a cappello TH 35-7,5
Top hat rail FH 35-7,5

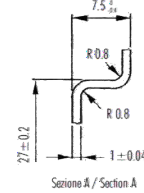

Profilato a cappello TH 35-15
Top hat rail TH 35-15

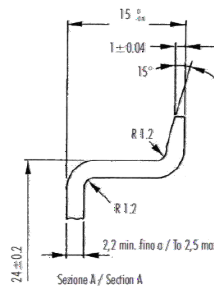

CARATTERISTICHE	METODO	UNITA' DI MISURA	BLENDE PCI/ABS
Meccaniche	Resistenza a trazione allo snervamento	ASTM D638	MPa
	Resistenza a trazione a rottura	ASTM D638	MPa
	Allungamento a rottura	ASTM D638	%
	Modulo in flessione	ASTM D790	MPa
Termiche	Temp. di ammolimento Vicat, metodo B	ASTM D1525	°C
	Temperatura Riccio 1.81 MPa	ASTM D648	°C
Fisiche	Flessione specifica	ASTM D792	g/cm ³
	Etire sulla stampa	ASTM D995	%
	Melt Flow Index 260°C - 99N	ASTM D1238	g/10'
Comportamento alla fiamma	Autestinguenza (min. di spessore)	UL94	V-0(0.8)
	Filo Intumescente 3.2 mm.	IEC695.2.1	°C

Italtronic si riserva il diritto di modificare il materiale con cui realizza i propri prodotti senza obbligo di preavviso.

FEATURES	TEST METHOD	UNITS	BLENDE PCI/ABS
Mechanical test	Resistance to tensile stress at yield	ASTM D638	MPa
	Tensile strength	ASTM D638	MPa
	Elongation at rupture	ASTM D638	%
	Bending modulus	ASTM D790	MPa
Thermal test	Heat test method	ISO 18074	KJ/m ²
	Vicat softening temperature method B	ASTM D1525	°C
Physical test	Rheology temperature 1.81 MPa	ASTM D648	°C
	Specific gravity	ASTM D792	g/cm ³
	Melt shrinkage	ASTM D995	%
Flame test	Melt Flow Index 260°C - 99N	ASTM D1238	g/10'
	Self-extinguish (thickness in mm)	UL94	V-0(0.8)
	Intumescent thread 3.2 mm.	IEC695.2.1	°C

Italtronic can operate any change of the materials without being obliged to forewarn.

For optimal operation of the product, it must be located in an electrical cabinet with IK08 mechanical protection. The minimum IP protection degree required is IP56.

16. Installation and Maintenance

Notes for installation:

- The installation position should be free from the following: dust or oil smoke, conductive dust, corrosive or flammable gas, high temperature, condensation, and rain.
- Besides, vibration and impact also affect the PLC normal operation and shorten its lifespan; electric shock, fire or misact also damages the product. During drilling or wiring, prevent the metal particles or wire segments from falling into the PLC casing, which may cause fire, fault, or misact.
- After the PLC installation, clean the ventilation duct to prevent blocking, which may cause bad ventilation, or even fire, faults, or misact.
- Do not online connect, plug or unplug cables, which is apt to cause electric shock or damage the circuit. Installation and wire connection must be firm and reliable. Poor connection could cause misact.
- Use shielded twisted pair for the I/O of high frequency signal and analog signal to improve system IMS.

The installation environment should be free from dust, oil smoke, conductive particles, corrosive or flammable gases, high temperature, condensation, and rain.

Besides, vibration and impact also affect the PLC normal operation and shorten its lifespan. It is recommended to install the PLC, together with the matching switches and contactors, in a dedicated electric cabinet and keep the cabinet ventilated. If the location has high ambient temperature or heat generating equipment nearby, install forced convection devices on top or sides of the cabinet to avoid over-temperature. During drilling or wiring, prevent the metal particles or wire segments from falling into the PLC casing, which may cause fire, fault or misact. After the PLC installation, clean the ventilation duct to prevent blocking, which may cause bad ventilation, or even fire, faults, or misact.

The only way to disconnect the equipment from the electrical network is by removing the connectors that feed the equipment. Once installed in the electrical cabinet it is very important to ensure the power connectors are for proper operation.

Separate the L-com PLC from heat, high voltage and electrical noise:

Always separate the devices that generate high voltage and high electrical noise from the PLC. When configuring the layout of the PLC inside your panel, consider the heat-generating devices and locate the electronic-type devices in the cooler areas of your cabinet. Reducing the exposure to a high-temperature environment will extend the operating life of any electronic device. Also consider the routing of the wiring for the devices in the electric cabinet. Avoid placing low-voltage signal wires and communications cables in the same tray with AC power wiring and high-energy, rapidly switched DC wiring.

Provide adequate clearance for cooling and wiring. The PLC is designed for natural convection cooling. For proper cooling, you must provide a clearance of at least 25 cm above and below the devices. Also, allow at least 25 cm of depth between the front of the modules and the inside of the enclosure.

Notes for maintenance:

A well-planned and executed maintenance program is essential to the satisfactory operation of solid-state electrical equipment. The kind and frequency of the maintenance operation will vary with the kind and complexity of the equipment as well as with the nature of the operating conditions. Maintenance recommendations of the manufacturer or appropriate product standards should be followed.

The following factors should be considered when formulating a maintenance program:

- Maintenance must be performed by qualified personnel familiar with the construction, operation, and hazards involved with control.
- Maintenance should be performed with the control out of operation and disconnected from all sources of power.
- Care should be taken when servicing electrostatic sensitive components. The manufacturer's recommendations for these components should be followed.
- Ventilation passages should be kept open. If the equipment depends upon auxiliary cooling, e.g., air, water, or oil, periodic inspection (with filter replacement when necessary) should be done by these systems.
- The means employed for grounding or insulating the equipment from the ground should be checked to assure its integrity.
- Accumulations of dust and dirt on all parts, including on semiconductor heat sinks, should be removed according to the manufacturer's instructions, if provided; otherwise, the manufacturer should be consulted. Care must be taken to avoid damaging any delicate components and to avoid displacing dust, dirt, or debris in a way that permits it to enter or settle into parts of the control equipment.
- Enclosures should be inspected for evidence of deterioration. Accumulated dust and dirt should be removed from the top of the enclosures before opening doors or removing covers.
- Certain hazardous materials removed as part of maintenance or repair procedures (e.g., polychlorinated biphenyls (PCBs) found in some liquid filled capacitors) must be disposed of as described in Federal regulations.

Safety rules for maintenance personnel

Consider the following steps to follow. A false maneuver could be the cause of an accident or material damage.

Do not disassemble or modify the modules. This could lead to breakdowns or malfunctions and could lead to injuries or fire.

- All types of radio communication devices, including mobile phones and personal handy-phone systems (PHS), must be kept more than **25cm** away from the PLC in all directions. Failure to observe this precaution exposes malfunctions caused by excess of temperature.
- Disconnect the external power supply of the system (on all phases) before connecting or disconnecting a module. Failure to observe this precaution may cause faults or malfunctions of the module.
- Tighten the screws of the terminal ports and the screws of the connectors within the prescribed tightening torque.

Insufficient tightening can lead to lose parts or wires and cause malfunctions. Excessive tightening can damage the screws and / or the module, with the risk of falling, short circuits, and malfunctions.

- Before handling a module, dispose of the electrostatic charge accumulated by the human body by touching a suitable conductive object. Failure to observe this precaution may cause faults or malfunctions of the module.

Repair note:

If the equipment is suitable to be repaired, it must be verified that the equipment remains in a safe state after repair.