

1. Quick Start Guide

This quick start guide describes how to install and use the Industrial Serial Device Server. Capable of operating at temperature extremes of -10°C to $+60^{\circ}\text{C}$, this is the Serial Device Server of choice for harsh environments constrained by space.

1.1. Physical Description

1.1.1. The Port Status LEDs and Power Inputs

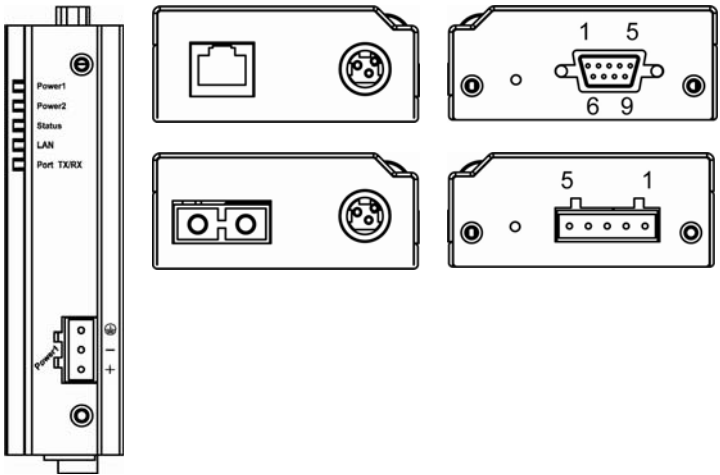

LED	State	Indication
Status (Orange)	Steady	Serial Device Server is not located by Xport utility yet.
	Flashing	Serial Device Server has been located by Xport utility.
Ethernet port: 10/100Base-TX, 100Base-FX		
LAN (Yellow)	Steady	A valid Ethernet network connection established.
	Flashing	Transmitting or receiving data.
Serial port		
Port TX/RX (Yellow)	Steady	A valid serial connection established.
	Flashing	Transmitting or receiving data.

Industrial Serial Device Server

Power Input Assignment			
Power1 (Yellow)	+	12-32VDC	Terminal Block
	-	Power Ground	
		Earth Ground	
Power2 (Yellow)		12VDC	DC Jack

There are Terminal Block and DC Jack power inputs can be used to power up this device. Redundant power supplies function is supported.

1.1.2. DIN-Rail Kits and optional Panel Mounting Kits

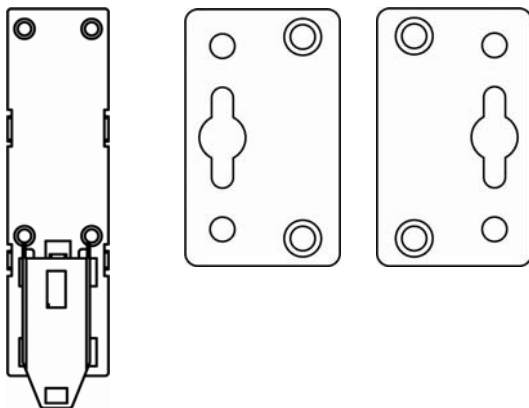

1.1.3. Pin Assignments of Serial Port

- **DB-9**

Pin	1	2	3	4	5	6	7	8	9
RS-232	DCD	RxD	TxD	DTR	Signal GND	DSR	RTS	CTS	RI
RS-422 4-wire RS-485	TxD+	RxD-	RxD+		Signal GND		TxD-		
2-wire RS-485		D-	D+		Signal GND				

- **Terminal Block**

Pin	1	2	3	4	5
RS-422 4-wire RS-485	RxD-	RxD+	Signal GND	TxD-	TxD+
2-wire RS-485	D-	D+	Signal GND		

1.2. Functional Description

- Flexible Serial Interface: DB9 for RS-232/422/485 or Terminal Block for RS-422/485.
- Isolation: 2KV isolated RS-422/485.
- Fiber Option: Support single-mode and multi-mode fiber optical.
- Flexible Power Input: Including both Terminal Block and DC Jack.
- Latch: DC Jack with latch secures higher stability of connection.
- Flexible Installation Method: Aluminum housing with panel and DIN-Rail mounting.
- Port Buffering: 64KB port buffer prevents data loss when connection fails.
- Warning: Inform user by relay output and E-mail in case of disconnection.
- Multiple Operation Mode: Support Virtual COM, TCP Server, TCP Client, UDP, Pair Connection.
- Reset button:
 - Reboot device: Press Reset button for 0~10 secs, Status LED flashes every 500 msecs.
 - Default password: Press Reset button for 11~30

Industrial Serial Device Server

secs, Status LED flashes every 200 msec.

- Factory default: Press Reset button for over 30 secs, Status LED flashes every 1 sec.

1.3. Utility Configuration

- Install Xport utility to the operating system of your computer and follow the on-screen instructions to finish the installation.
- Double click the Xport icon on your computer screen to launch the Xport utility.
- Double click IP Address 192.168.1.10 on the Device List. A web-based login window will be shown as below.

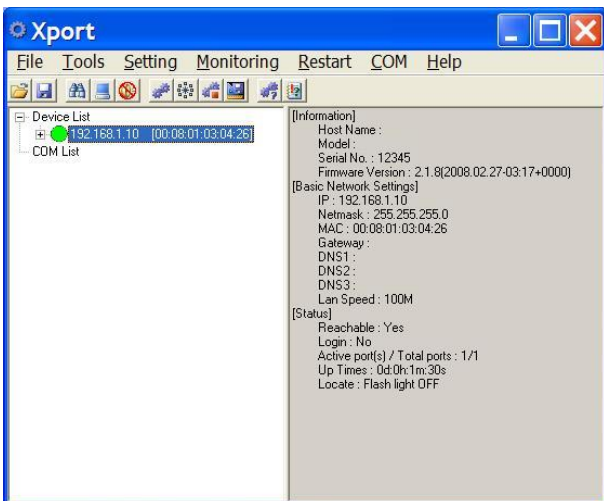

1.4. Web Configuration

- Login the Serial Device Server:
Specify the default IP address (192.168.1.10) of the Serial Device Server in the web browser. A web-based login window will be shown as below:

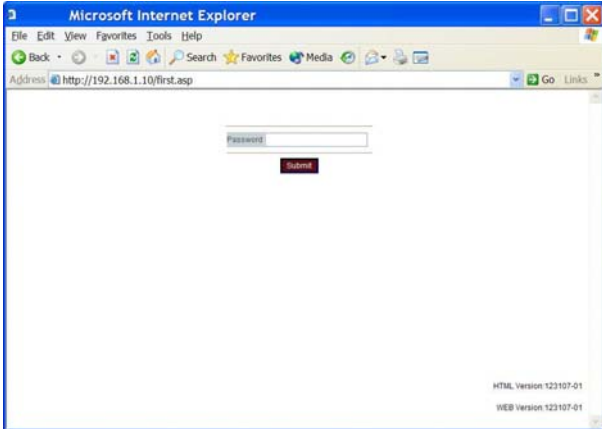

- Enter the factory default password: admin.
Then click on the "Submit" button to log on to the Serial Device Server.

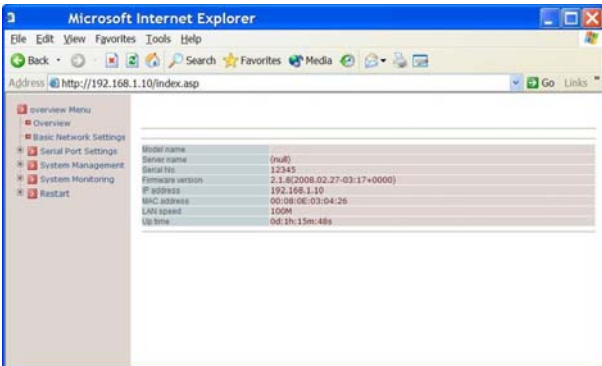

2. Table of Contents

1.	Quick Start Guide	1
1.1.	Physical Description	1
1.1.1.	The Port Status LEDs and Power Inputs.....	1
1.1.2.	DIN-Rail Kits and optional Panel Mounting Kits.....	2
1.1.3.	Pin Assignments of Serial Port.....	3
1.2.	Functional Description	3
1.3.	Utility Configuration	4
1.4.	Web Configuration	5
2.	Table of Contents	6
3.	Introduction	8
3.1.	Overview.....	8
3.2.	Features.....	9
4.	Getting Started	10
4.1.	Packaging.....	10
4.2.	Interfaces.....	10
4.3.	Installation Procedures.....	12
5.	Software Setup	13
5.1.	Default Settings.....	13
5.2.	IP Assignment.....	13
5.2.1.	Configure IP by Xport Utility.....	13
5.2.2.	Configure IP by web interface.....	14
5.2.3.	Configure IP by Telnet utility.....	15
5.2.4.	Auto IP with DHCP.....	15
5.3.	TCP/IP Port Number.....	15
6.	Configure Serial Device Server by web interface	16
6.1.	Login to System.....	16
6.2.	Overview Menu.....	16
6.2.1.	Overview.....	17
6.2.2.	Basic Network Settings.....	18
6.3.	Serial Port Settings.....	19
6.3.1.	Port Status.....	20
6.3.2.	Port.....	20
6.4.	System Management.....	36
6.4.1.	Server Name Setting.....	36
6.4.2.	Change Password.....	37
6.4.3.	E-mail Alert.....	38
6.4.4.	SNMP Trap.....	38
6.4.5.	Restore Factory Default.....	39
6.4.6.	Firmware Update.....	40
6.5.	System Monitoring.....	40
6.5.1.	Serial to Network Connections.....	40
6.5.2.	System Log.....	41
6.5.3.	Event Log.....	41
6.6.	Restart.....	42
6.6.1.	Restart Port.....	42
6.6.2.	Restart System.....	43
7.	Telnet Configuration	44
7.1.	Overview.....	45
7.2.	Basic Network Settings.....	45
7.3.	Serial Port Settings.....	46
7.3.1.	Port Status.....	46
7.3.2.	Operation Modes.....	47
7.3.3.	Communication Parameters.....	50

Industrial Serial Device Server

7.3.4.	Accessible IP List	51
7.4.	System Management	51
7.4.1.	Server Name Setting	52
7.4.2.	Change Password	52
7.4.3.	E-mail Alert	52
7.4.4.	SNMP Trap	53
7.4.5.	Restore Factory Default	53
7.5.	System Monitoring	53
7.5.1.	Serial to Network Connections	54
7.5.2.	System Log	54
7.5.3.	Event Log	55
7.6.	Restart.....	55
7.6.1.	Restart Port	56
7.6.2.	Restart System	56
8.	Xport Utility	57
8.1.	Xport Utility Introduction	57
8.2.	Interface.....	57
8.3.	Device List	57
8.3.1.	Login to System by Web Interface	57
8.3.2.	Functions	58
8.3.3.	Serial port	59
8.3.4.	COM List.....	64
8.4.	File.....	66
8.4.1.	Logon	66
8.4.2.	Logoff	67
8.4.3.	Load utility setting.....	67
8.4.4.	Save utility setting.....	68
8.4.5.	Exit	68
8.5.	Tools	68
8.5.1.	Auto-search	69
8.5.2.	Manual-search.....	69
8.5.3.	Locate.....	70
8.6.	Setting	70
8.6.1.	Serial Port Settings	70
8.6.2.	Basic Network Settings.....	89
8.6.3.	System Management.....	90
8.6.4.	Utility Setting	92
8.7.	Monitoring.....	93
8.7.1.	Port Status	94
8.7.2.	Logs	94
8.8.	Restart.....	95
8.8.1.	Restart Port	96
8.8.2.	Restart System	96
8.8.3.	Restart All Ports	97
8.9.	COM	97
8.9.1.	Create a new COM port.....	98
8.9.2.	Remove all COM ports.....	99
8.10.	Help	99
9.	Specifications.....	101
9.1.	Hardware Specifications.....	101
9.2.	Pin Assignments.....	102

3. Introduction

3.1. Overview

This Serial Device Server is a gateway between Ethernet (TCP/IP) and RS-232 / RS-422 / RS-485 communications. It allows almost any serial device to be connected to a new or existing Ethernet network. The information transmitted by this Serial Device Server is transparent to both host computers (IP network over Ethernet) and devices (RS-232 / RS-422 / RS-485). Data from the Ethernet (TCP/IP) is transmitted to the designated RS-232 / RS-422 / RS-485 port and data from RS-232 / RS-422 / RS-485 port is transmitted to the Ethernet (TCP/IP) transparently.

In the computer integration manufacturing or industrial automation area, Serial Device Server is used for field devices to direct connect to network. Terminal Server (main control program run in this Serial Device Server) transforms whatever data received from RS-232 / RS-422 / RS-485 to TCP/UDP port then connects devices to the IP network via a single application program or multiple application programs.

Many control devices provide the ability to communicate with hosts through RS-232 / RS-422 / RS-485 however RS-232 / RS-422 / RS-485 serial communication has its limitations. For instance, it is hard to transfer data through a long distance. With this Serial Device Server, it is possible to communicate with a remote device in the Intranet environment or even in the Internet and thus, increases the communication distance dramatically.

Flexible configuration options enable this unit to be setup remotely over IP network by Telnet, web browser, or Window utility. Packed in a rugged DIN Rail mountable case and 12~32V DC power input range, this Serial Device Server is ideal for almost any industrial and manufacturing automation.

3.2. Features

- Flexible Serial Interface- RS-232 / 422 / 485 or RS-422 / 485
- Isolation- 2KV isolated RS-422 / 485
- Fiber Option- Support single-mode and multi-mode fiber optics
- Flexible Power Input- Including both terminal block and DC jack
- Latch- DC jack with latch secures a stable connection
- Flexible Installation Method- Aluminum housing with panel and DIN-Rail mounting
- Port Buffering- 64KB port buffer prevents data loss when connection fails
- Warning- Inform user by relay output and E-mail in case of disconnection
- Multiple Operation Mode- Support Real COM, TCP server, TCP client, UDP, Pair Connection
- Reset button:
 - Reboot device: Press Reset button for 0~10 secs, Status LED flashes every 500 msec.
 - Default password: Press Reset button for 11~30 secs, Status LED flashes every 200 msec.
 - Factory default: Press Reset button for over 30 secs, Status LED flashes every 1 sec.

4. Getting Started

4.1. Packaging

- Serial Device Server x 1
- 5 pins Terminal Block for Serial Connector x 1
- 3 pins Terminal Block for Power Connector x 1
- Mini DIN to DB-9 cable x 1
- Serial Device Server Quick Start Guide x 1
- Product CD containing configuration utility and other tools

4.2. Interfaces



Fig 1. Serial Device Server Interfaces

Industrial Serial Device Server

LED	State	Indication
Status (Orange)	Steady	Serial Device Server is not located by Xport utility yet.
	Flashing	Serial Device Server has been located by Xport utility.
Ethernet port: 10/100Base-TX, 100Base-FX		
LAN (Yellow)	Steady	A valid Ethernet network connection established.
	Flashing	Transmitting or receiving data.
Serial port		
Port TX/RX (Yellow)	Steady	A valid serial connection established.
	Flashing	Transmitting or receiving data.

Power Input Assignment			
Power1 (Yellow)	+	12-32VDC	Terminal Block
	-	Power Ground	
		Earth Ground	
Power2 (Yellow)		12VDC	DC Jack

4.3. Installation Procedures

- Prepare necessary cables, DC power adapter and serial connector.
- Connect Serial Device Server to Ethernet cable with RJ45 connector.
- Connect serial port of Serial Device Server to serial device, make sure the connector and wiring of RS-232 is correct.
- Plug in Serial Device Server to 12-32VDC power source (3-pin terminal block connector) or 12VDC power source (DC jack connector).

Use Xport utility on the product CD to check the status of Serial Device Server. If it starts up successfully, User shall find the IP and MAC address of Serial Device Server. User can change IP address, gateway IP address and subnet mask networking parameters of Serial Device Server according to user networking configurations.

5. Software Setup

Now the Serial Device Server hardware is installed and power is on, network IP configuration will be set in this section.

5.1. Default Settings

These default IP addresses settings are shown from under information.

Default IP addresses

Interface	Device IP	Subnet mask	Gateway IP
LAN Port	192.168.1.10	255.255.255.0	

The other default settings of Serial Device Server are shown in the following table.

Property	Default Value
Ethernet Port	
IP Address	192.168.1.10
Gateway	
Subnet Mask	255.255.255.0
Security	
Password	admin
Serial	
COM	9600/None/8/1, No flow control
Link Mode	TCP Server, TCP port 601

Table 1. Default settings of the Serial Device Server

- * **Note:** Press reset button for 3 to 10 seconds to the default password. Press reset button for over 10 seconds to reboot the Serial Device Server.

5.2. IP Assignment

5.2.1. Configure IP by Xport Utility

Use Xport utility that comes with product CD or diskette to configure the network parameters.

Find new device and IP assignment

Industrial Serial Device Server

- Use Xport Utility for finding new device IP address, get device's current IP from Device List.
- Re-assigned IP, network mask and gateway if need with Xport Utility.
- User can configure Password and Server Name with Xport Utility.

Network setting

Network Settings

DHCP

IP address: 192.168.1.10

Netmask: 255.255.255.0

Gateway: . . .

DNS server 1: . . .

DNS server 2: . . .

DNS server 3: . . .

Time Settings

Time zone (24-hour): [dropdown]

Local time: 2008/03/27 [dropdown] 18:34:11 [spinner]

Time server: [text box] Enable

[Update] [Close]

Fig 2. IP settings for Xport Utility tool

5.2.2. Configure IP by web interface

Use common Web browser, ex. Microsoft Internet Explorer or Mozilla Firefox, to configure the network parameters of Serial Device Server.

- Open web browser, type in the IP address (default IP: 192.168.1.10) of Serial Device Server to be configured. Default password is admin.
- Configure IP settings from web Network links page then click "Submit" to save settings.
- Click on "Restart" button to reboot the Serial Device

Server.

5.2.3. Configure IP by Telnet utility

Use common Telnet utility, ex. Microsoft Command Prompt or Hyper-terminal, to configure the network parameters of Serial Device Server.

- Run command telnet "IP address" to telnet to Serial Device Server. Default IP address is 192.168.1.10 and default password is admin.
- Configure IP settings from Basic Network Settings menu, and restart system after saved settings.

5.2.4. Auto IP with DHCP

DHCP server will automatically supply an IP address, gateway address, and subnet mask to Serial Device Server. By default, the DHCP client function on Serial Device Server is disabled, user can activate the DHCP functions by the following steps.

- Execute Xport Utility
- Click on the IP address (of Serial Device Server)
- Click "Basic Network Settings" from "Setting" to pop-up the Network setting Window
- Check "DHCP"
- Click "Update" (The Serial Device Server will restart and obtain the IP from the DHCP server automatically)

5.3. TCP/IP Port Number

Default Port number of Serial Device Server is 601 (1st port) and it can be associated with the serial COM port of host computer by using Xport utility. After the application program being connected to the TCP port 601 on the Serial Device Server, data of user's application program are transmitted transparently to Serial Device Server and vice versa.

6. Configure Serial Device Server by web interface

User has to assign IP address to Serial Device Server before working on web configuration operations.

6.1. Login to System

Open one of the web browsers, ex. Microsoft IE or Firefox etc. Enter the IP address of Serial Device Server on the URL. Example: *http://192.168.1.10*

The following authentication screen shall appear. Enter password then click on “Submit”. The default password is “admin”.

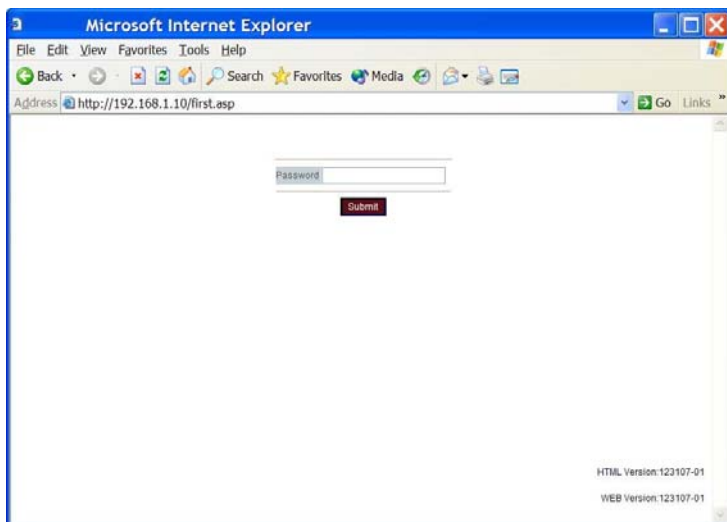

Fig 3. Authorization request for system security
The overview screen shall appear (Fig. 4).

6.2. Overview Menu

This system overview window gives the general information on Serial Device Server that includes Overview and Basic

Network Settings.

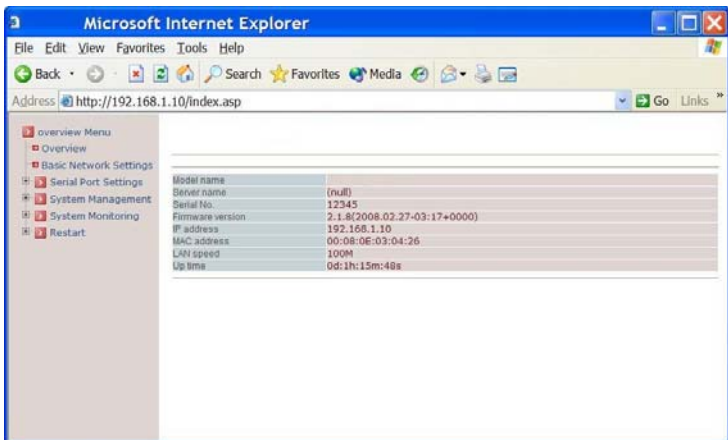

Fig 4. Overview for system information by Web Interface

6.2.1. Overview

Serial Device Server's system information includes model name, Server Name, Serial No., Firmware version, IP address, MAC address, LAN speed, and Up time. The information is read only and is attributed from another setting page or system status.

Industrial Serial Device Server

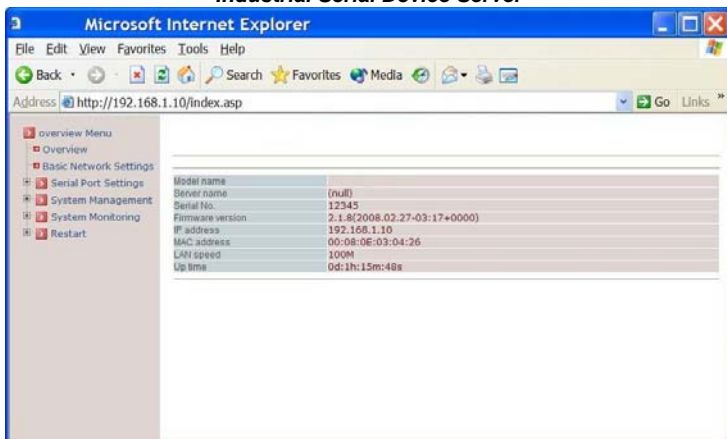

Fig 5. Device Information from Overview web page

6.2.2. Basic Network Settings

There are two sections allowed to be changed on Basic Network Settings page that includes Network Settings and Time Settings.

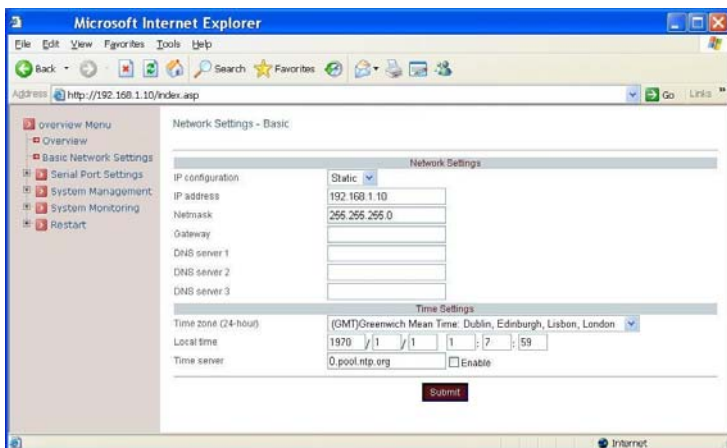

Fig 6. Network information by Web page

Network Settings

Operation: Basic Network Settings → Network Settings

- IP configuration: Click “IP configuration” drop-down menu to choose “Static” or “DHCP” from the “IP configuration” drop-down list so user manually assigns or DHCP server automatically supplies an IP address, gateway address, and subnet mask to Serial Device Server.
- IP address: Click in “IP address” text box and type a new address to change the IP address.
- Netmask: Click in “Netmask” text box and type a new address to change the Netmask.
- Gateway: Click in “Gateway” text box and type a new address to change the Gateway.
- DNS server 1, 2, 3: Click in “DNS server 1”, “DNS server 2”, or “DNS server 3” text box and fill in DNS information.

Time Settings

Operation: Basic Network Settings → Time Settings

- Time zone (24-hour): Click “Time zone” drop-down menu to select a different time zone from the “Time zone” drop-down list.
- Local time: Click in “Local time” text box to set date and time the Serial Device Server.
- Time server: Click in “Time server” text box to enter Time server address for the Serial Device Server. And check “Enable” to enable this setting.

Click “Submit” button when you finished Basic Network Settings.

6.3. Serial Port Settings

Here User can configure Serial Port Settings that includes Port Status and Port defined by user.

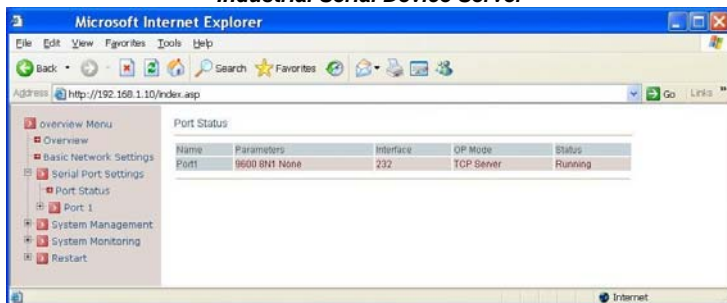

Fig 7. Port Status Web Page

6.3.1. Port Status

Click on the “Port Status” link from “Serial Port Settings” and the Fig 7. screen will appear.

6.3.2. Port

Virtual Com Mode Setting

The Xport utility map a serial port to a COM port on a PC.

1. Operation Modes

- Application: Click “Application” drop-down menu to select “Virtual Com” from the “Application” drop-down list.
- RFC2217: RFC2217 is used to establish a transparent connection between a host computer and a serial device by mapping the serial port on the Serial Device Server to a local COM port on the host computer. RFC2217 is always enabled for Virtual Com Mode Setting.
- TCP Port: Click in “TCP Port” text box and type a TCP Port number assigned to the serial port on the Serial Device Server. The default TCP Port number is 601.
- Max-client: The maximum number of host computers that can receive data from the Serial Device Server simultaneously. Click “Max-client” drop-down menu to select 1 ~ 8 from the “Max-client” drop-down list.
- Apply the above settings to all serial ports: Check this option to apply the above settings to all serial ports.

Click “Submit” button when you finished Virtual Com Mode Setting.

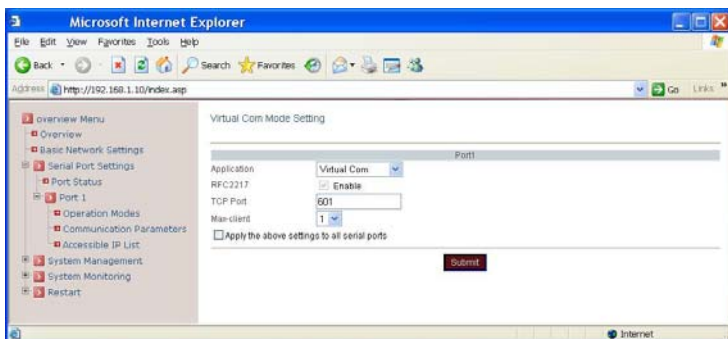

Fig 8. Virtual Com Mode Setting

2. Communication Parameters

- Protocol timeout auto-detect: Check this option to support Protocol timeout auto-detect. The Serial Device Server will automatically test the TCP connection to remote host. If the TCP connection is idle, the TCP connection will be closed and the port will be freed for other hosts.
- Protocol timeout: Click in “Protocol timeout” text box and type a period of Protocol timeout assigned to the serial port on the Serial Device Server. The connection will be closed and the port will be freed for connection with other hosts when serial port stops data transmission for a defined period of time (Protocol timeout). The default Protocol timeout is 0ms.
- Baud rate: Click “Baud rate” drop-down menu to select Baud rate 50 ~ 460800bps from the “Baud rate” drop-down list for the serial port. The default Baud rate of the serial port is 9600bps.
- Data bits: Click “Data bits” drop-down menu to select Data bits 5, 6, 7, or 8 from the “Data bits” drop-down list for the serial port. The default Data bits of the serial port is 8 bits.
- Stop bits: Click “Stop bits” drop-down menu to select Stop bits 1 or 2 from the “Stop bits” drop-down list for the serial port. The default Stop bits of the serial port is 1 bit.

Industrial Serial Device Server

- Parity: Click “Parity” drop-down menu to select Parity None, Odd, Even, Mark, or Space from the “Parity” drop-down list for the serial port. The default Parity of the serial port is None.
- Flow control: Click “Flow control” drop-down menu to select Flow control None, Hardware, or Software from the “Flow control” drop-down list for the serial port. The default Flow control of the serial port is None.
- Mode: Click “Mode” drop-down menu to select Mode RS232, RS485, or RS422 from the “Mode” drop-down list for the serial port. The default Mode of the serial port is RS232.
- Delimiter1, 2: Click in “Delimiter1, 2” text box and Delimiter1, 2 assigned to the serial port on the Serial Device Server. Check this option to enable Delimiter1, 2. The data will be transmitted if the Delimiter1 is received or Delimiter1 and Delimiter are received.
- Force transmit: Click in “Force transmit” text box and specify Force transmit to the serial port on the Serial Device Server. The data will be transmitted when the Force transmit is reached. The default Force transmit of the serial port is 0 to disable Force transmit.
- Apply the above settings to all serial ports: Check this option to apply the above settings to all serial ports.

Click “Submit” button when you finished Communication Parameters.

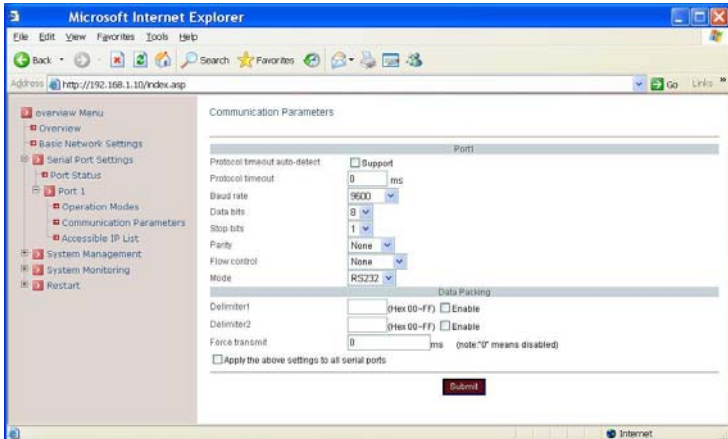

Fig 9. Communication Parameters

3. Accessible IP List

- Enable the accessible IP list: Check this option to enable the accessible IP list. Disable will allow all IP's connection request.
- IP1 ~ 8: Click in "IP1 ~ 8" text box and specify IP addresses that can access to the serial port on the Serial Device Server. Check this option to enable the IP addresses.
- Apply the above settings to all serial ports: Check this option to apply the above settings to all serial ports.

Click "Submit" button when you finished Accessible IP List.

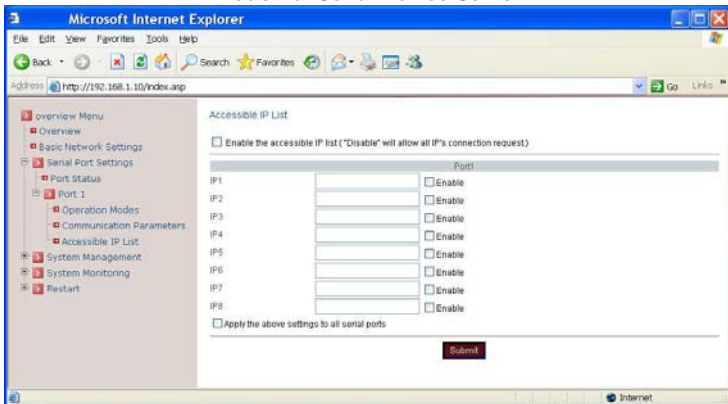

Fig 10. Accessible IP List

Pair Connection

One Serial Device Server is assigned as the “master” and the other Serial Device Server as the “slave”.

1. Operation Modes

- Application: Click “Application” drop-down menu to select “Pair Connection” from the “Application” drop-down list.
- RFC2217: RFC2217 is used to establish a transparent connection between a host computer and a serial device by mapping the serial port on the Serial Device Server to a local COM port on the host computer. RFC2217 is always enabled for Pair Connection Setting.
- Mode: Click “Mode” drop-down menu to select Master or Slave from the “Mode” drop-down list.
- IP: Click in “IP” text box and specify the IP address of the Slave Serial Device Server of Pair Connection.
- TCP Port: Click in “TCP Port” text box and type a TCP Port number assigned to the serial port on the Serial Device Server. The default TCP Port number is 601.
- Apply the above settings to all serial ports: Check this option to apply the above settings to all serial ports.

Click “Submit” button when you finished Pair Connection Setting.

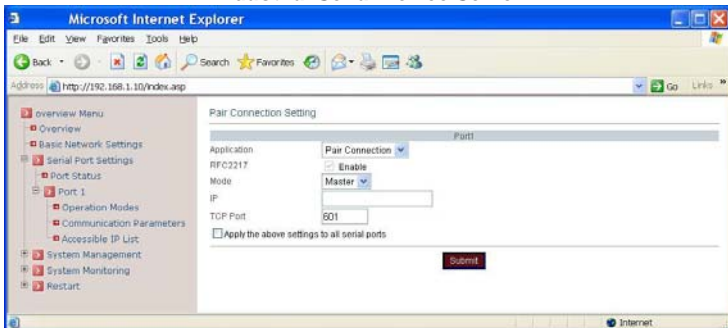

Fig 11. Pair Connection Setting

2. Communication Parameters

- Protocol timeout auto-detect: Check this option to support Protocol timeout auto-detect. The Serial Device Server will automatically test the TCP connection to remote host. If the TCP connection is idle, the TCP connection will be closed and the port will be freed for other hosts.
- Protocol timeout: Click in “Protocol timeout” text box and type a period of Protocol timeout assigned to the serial port on the Serial Device Server. The connection will be closed and the port will be freed for connection with other hosts when serial port stops data transmission for a defined period of time (Protocol timeout). The default Protocol timeout is 0ms.
- Baud rate: Click “Baud rate” drop-down menu to select Baud rate 50 ~ 460800bps from the “Baud rate” drop-down list for the serial port. The default Baud rate of the serial port is 9600bps.
- Data bits: Click “Data bits” drop-down menu to select Data bits 5, 6, 7, or 8 from the “Data bits” drop-down list for the serial port. The default Data bits of the serial port is 8 bits.
- Stop bits: Click “Stop bits” drop-down menu to select Stop bits 1 or 2 from the “Stop bits” drop-down list for the serial port. The default Stop bits of the serial port is 1 bit.
- Parity: Click “Parity” drop-down menu to select Parity None, Odd, Even, Mark, or Space from the “Parity” drop-down list for the serial port. The default Parity of the serial port is None.

Industrial Serial Device Server

- Flow control: Click “Flow control” drop-down menu to select Flow control None, Hardware, or Software from the “Flow control” drop-down list for the serial port. The default Flow control of the serial port is None.
- Mode: Click “Mode” drop-down menu to select Mode RS232, RS485, or RS422 from the “Mode” drop-down list for the serial port. The default Mode of the serial port is RS232.
- Delimiter1, 2: Click in “Delimiter1, 2” text box and Delimiter1, 2 assigned to the serial port on the Serial Device Server. Check this option to enable Delimiter1, 2. The data will be transmitted if the Delimiter1 is received or Delimiter1 and Delimiter are received.
- Force transmit: Click in “Force transmit” text box and specify Force transmit to the serial port on the Serial Device Server. The data will be transmitted when the Force transmit is reached. The default Force transmit of the serial port is 0 to disable Force transmit.
- Apply the above settings to all serial ports: Check this option to apply the above settings to all serial ports.

Click “Submit” button when you finished Communication Parameters.

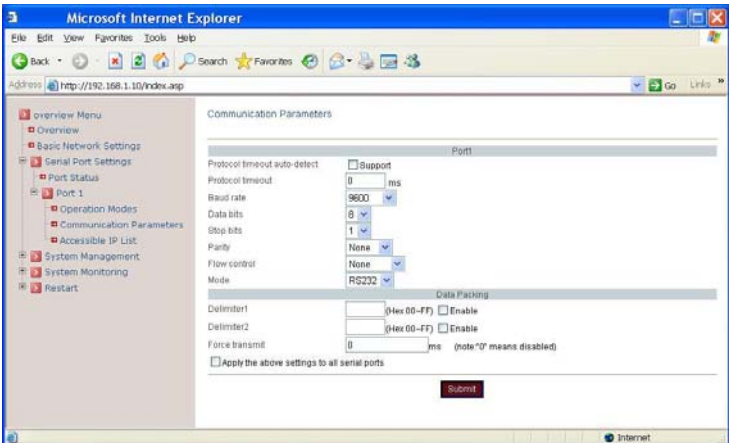

Fig 12. Communication Parameters

TCP Server Setting

TCP Server mode is default Link mode of Serial Settings, and it can wait for connecting requests from remote host PCs which running Xport utility. Default TCP Port number of serial port on Serial Device Server is 601.

1. Operation Modes

- Application: Click “Application” drop-down menu to select “TCP Server” from the “Application” drop-down list.
- RFC2217: RFC2217 is used to establish a transparent connection between a host computer and a serial device by mapping the serial port on the Serial Device Server to a local COM port on the host computer. Check this option to enable RFC2217 for TCP Server Setting.
- TCP Port: Click in “TCP Port” text box and type a TCP Port number assigned to the serial port on the Serial Device Server. The default TCP Port number is 601.
- Max-client: The maximum number of host computers that can receive data from the Serial Device Server simultaneously. Click “Max-client” drop-down menu to select 1 ~ 8 from the “Max-client” drop-down list.
- Apply the above settings to all serial ports: Check this option to apply the above settings to all serial ports.

Click “Submit” button when you finished TCP Server Setting.

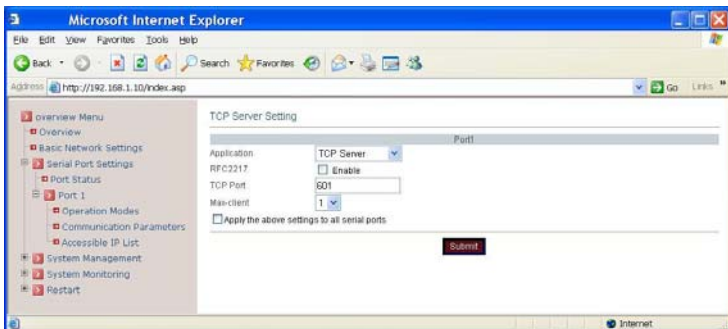

Fig 13. TCP Server Setting

2. Communication Parameters

Industrial Serial Device Server

- Protocol timeout auto-detect: Check this option to support Protocol timeout auto-detect. The Serial Device Server will automatically test the TCP connection to remote host. If the TCP connection is idle, the TCP connection will be closed and the port will be freed for other hosts.
- Protocol timeout: Click in “Protocol timeout” text box and type a period of Protocol timeout assigned to the serial port on the Serial Device Server. The connection will be closed and the port will be freed for connection with other hosts when serial port stops data transmission for a defined period of time (Protocol timeout). The default Protocol timeout is 0ms.
- Baud rate: Click “Baud rate” drop-down menu to select Baud rate 50 ~ 460800bps from the “Baud rate” drop-down list for the serial port. The default Baud rate of the serial port is 9600bps.
- Data bits: Click “Data bits” drop-down menu to select Data bits 5, 6, 7, or 8 from the “Data bits” drop-down list for the serial port. The default Data bits of the serial port is 8 bits.
- Stop bits: Click “Stop bits” drop-down menu to select Stop bits 1 or 2 from the “Stop bits” drop-down list for the serial port. The default Stop bits of the serial port is 1 bit.
- Parity: Click “Parity” drop-down menu to select Parity None, Odd, Even, Mark, or Space from the “Parity” drop-down list for the serial port. The default Parity of the serial port is None.
- Flow control: Click “Flow control” drop-down menu to select Flow control None, Hardware, or Software from the “Flow control” drop-down list for the serial port. The default Flow control of the serial port is None.
- Mode: Click “Mode” drop-down menu to select Mode RS232, RS485, or RS422 from the “Mode” drop-down list for the serial port. The default Mode of the serial port is RS232.
- Delimiter1, 2: Click in “Delimiter1, 2” text box and Delimiter1, 2 assigned to the serial port on the Serial Device Server. Check this option to enable Delimiter1, 2. The data will be transmitted if the Delimiter1 is received or Delimiter1 and Delimiter are received.
- Force transmit: Click in “Force transmit” text box and

Industrial Serial Device Server

specify Force transmit to the serial port on the Serial Device Server. The data will be transmitted when the Force transmit is reached. The default Force transmit of the serial port is 0 to disable Force transmit.

- Apply the above settings to all serial ports: Check this option to apply the above settings to all serial ports.

Click “Submit” button when you finished Communication Parameters.

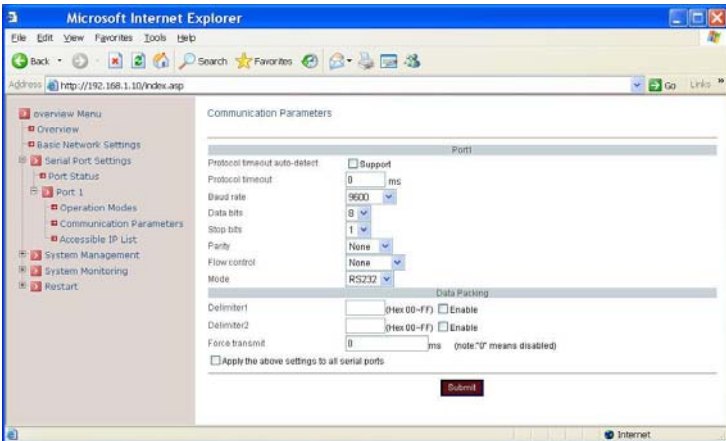

Fig 14. Communication Parameters

3. Accessible IP List

- Enable the accessible IP list: Check this option to enable the accessible IP list. Disable will allow all IP's connection request.
- IP1 ~ 8: Click in “IP1 ~ 8” text box and specify IP addresses that can access to the serial port on the Serial Device Server. Check this option to enable the IP addresses.
- Apply the above settings to all serial ports: Check this option to apply the above settings to all serial ports.

Click “Submit” button when you finished Accessible IP List.

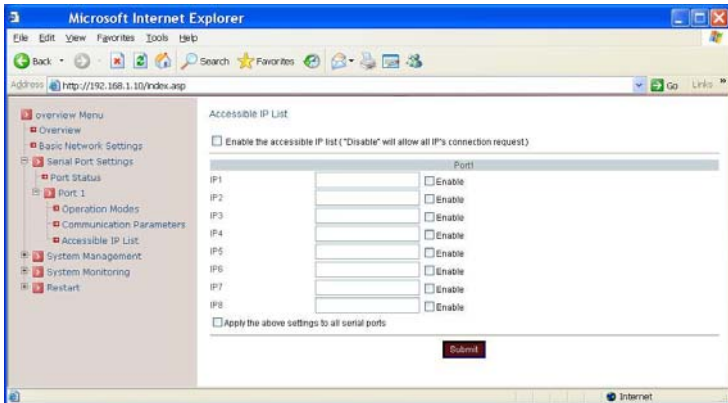

Fig 15. Accessible IP List

TCP Client Setting

User may enter IP addresses and port numbers of remote host computers to establish connection from Serial Device Server to remote host computers.

1. Operation Modes

- Application: Click “Application” drop-down menu to select “TCP Client” from the “Application” drop-down list.
- RFC2217: RFC2217 is used to establish a transparent connection between a host computer and a serial device by mapping the serial port on the Serial Device Server to a local COM port on the host computer. Check this option to enable RFC2217 for TCP Client Setting.
- Connect timeout: Click in “Connect timeout” text box and type a period of Connect timeout assigned to the serial port on the Serial Device Server. The connection will be closed and the port will be freed for connection with other hosts when serial port stops data transmission for a defined period of time (Connect timeout). The default Connect timeout is 3 seconds.
- Re-connect interval: Click in “Re-connect interval” text box and type a period of Re-connect interval assigned to the serial port on the Serial Device Server. The connection will be reestablished with other hosts for a defined period of time (Re-connect interval). The default

Industrial Serial Device Server

Re-connect interval is 3 seconds.

- IP1 ~ 8, Port: Click in “IP1 ~ 8” and “Port” text boxes to specify IP addresses and Port numbers of remote host computers.
- Apply the above settings to all serial ports: Check this option to apply the above settings to all serial ports.

Click “Submit” button when you finished TCP Client Setting.

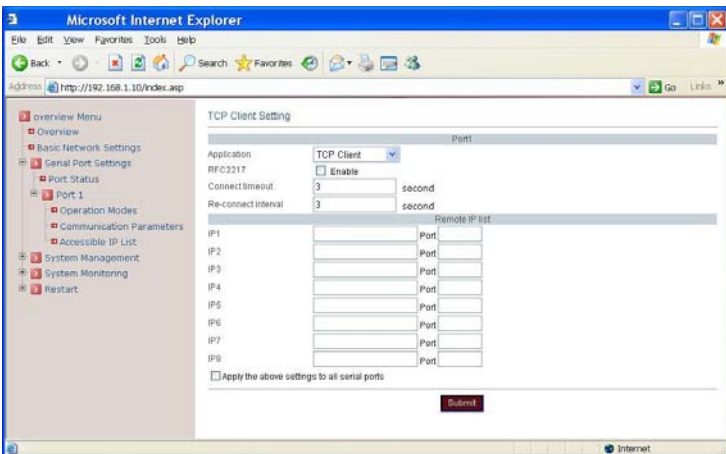

Fig 16. TCP Client Setting

2. Communication Parameters

- Protocol timeout auto-detect: Check this option to support Protocol timeout auto-detect. The Serial Device Server will automatically test the TCP connection to remote host. If the TCP connection is idle, the TCP connection will be closed and the port will be freed for other hosts.
- Protocol timeout: Click in “Protocol timeout” text box and type a period of Protocol timeout assigned to the serial port on the Serial Device Server. The connection will be closed and the port will be freed for connection with other hosts when serial port stops data transmission for a defined period of time (Protocol timeout). The default Protocol timeout is 0ms.
- Baud rate: Click “Baud rate” drop-down menu to select Baud rate 50 ~ 460800bps from the “Baud rate”

Industrial Serial Device Server

drop-down list for the serial port. The default Baud rate of the serial port is 9600bps.

- Data bits: Click “Data bits” drop-down menu to select Data bits 5, 6, 7, or 8 from the “Data bits” drop-down list for the serial port. The default Data bits of the serial port is 8 bits.
- Stop bits: Click “Stop bits” drop-down menu to select Stop bits 1 or 2 from the “Stop bits” drop-down list for the serial port. The default Stop bits of the serial port is 1 bit.
- Parity: Click “Parity” drop-down menu to select Parity None, Odd, Even, Mark, or Space from the “Parity” drop-down list for the serial port. The default Parity of the serial port is None.
- Flow control: Click “Flow control” drop-down menu to select Flow control None, Hardware, or Software from the “Flow control” drop-down list for the serial port. The default Flow control of the serial port is None.
- Mode: Click “Mode” drop-down menu to select Mode RS232, RS485, or RS422 from the “Mode” drop-down list for the serial port. The default Mode of the serial port is RS232.
- Delimiter1, 2: Click in “Delimiter1, 2” text box and Delimiter1, 2 assigned to the serial port on the Serial Device Server. Check this option to enable Delimiter1, 2. The data will be transmitted if the Delimiter1 is received or Delimiter1 and Delimiter are received.
- Force transmit: Click in “Force transmit” text box and specify Force transmit to the serial port on the Serial Device Server. The data will be transmitted when the Force transmit is reached. The default Force transmit of the serial port is 0 to disable Force transmit.
- Apply the above settings to all serial ports: Check this option to apply the above settings to all serial ports.

Click “Submit” button when you finished Communication Parameters.

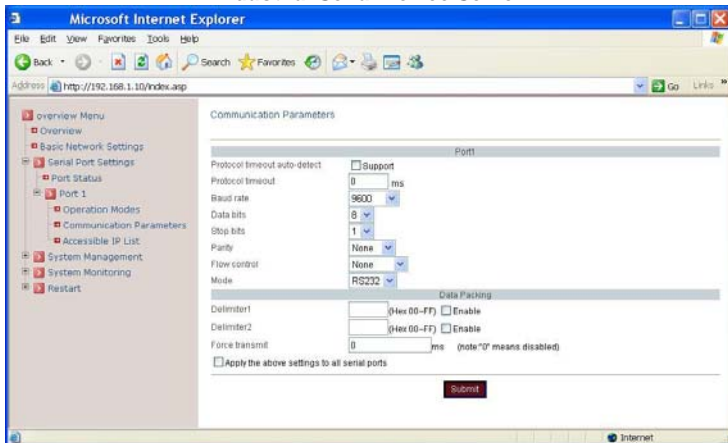

Fig 17. Communication Parameters

UDP Setting

Serial Device Server can be configured in a UDP mode to establish connection using Unicast or Multicast data from the serial device to one or multiple host computers. Vice versa is also true.

1. Operation Modes

- Application: Click “Application” drop-down menu to select “UDP” from the “Application” drop-down list.
- Server1 ~ 8, Port: Click in “Server1 ~ 8” and “Port” text boxes to specify IP addresses and Port numbers of remote UDP Servers.
- UDP Port: Click in “UDP Port” text box and type a UDP Port number assigned to the Source UDP Clients. The default UDP Port number is 601.
- Source IP 1 ~ 8: Click in “Source IP 1 ~ 8” text box to specify IP addresses of Source UDP Clients.
- Apply the above settings to all serial ports: Check this option to apply the above settings to all serial ports.

Click “Submit” button when you finished UDP Setting.

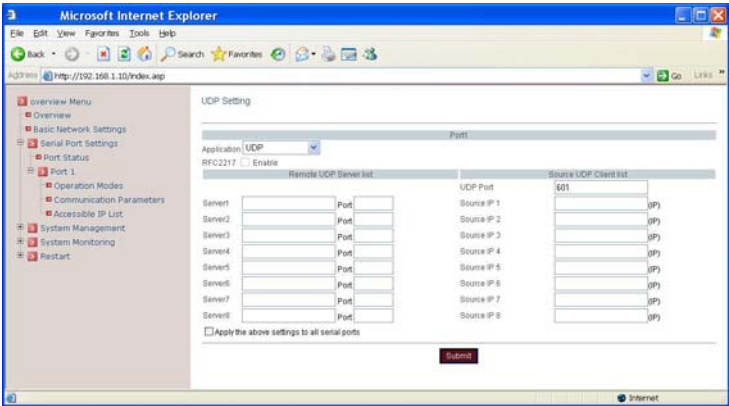

Fig 18. UDP Setting

2. Communication Parameters

- Protocol timeout auto-detect: Check this option to support Protocol timeout auto-detect. The Serial Device Server will automatically test the TCP connection to remote host. If the TCP connection is idle, the TCP connection will be closed and the port will be freed for other hosts.
- Protocol timeout: Click in “Protocol timeout” text box and type a period of Protocol timeout assigned to the serial port on the Serial Device Server. The connection will be closed and the port will be freed for connection with other hosts when serial port stops data transmission for a defined period of time (Protocol timeout). The default Protocol timeout is 0ms.
- Baud rate: Click “Baud rate” drop-down menu to select Baud rate 50 ~ 460800bps from the “Baud rate” drop-down list for the serial port. The default Baud rate of the serial port is 9600bps.
- Data bits: Click “Data bits” drop-down menu to select Data bits 5, 6, 7, or 8 from the “Data bits” drop-down list for the serial port. The default Data bits of the serial port is 8 bits.
- Stop bits: Click “Stop bits” drop-down menu to select Stop bits 1 or 2 from the “Stop bits” drop-down list for the serial port. The default Stop bits of the serial port is 1 bit.
- Parity: Click “Parity” drop-down menu to select Parity

Industrial Serial Device Server

None, Odd, Even, Mark, or Space from the “Parity” drop-down list for the serial port. The default Parity of the serial port is None.

- Flow control: Click “Flow control” drop-down menu to select Flow control None, Hardware, or Software from the “Flow control” drop-down list for the serial port. The default Flow control of the serial port is None.
- Mode: Click “Mode” drop-down menu to select Mode RS232, RS485, or RS422 from the “Mode” drop-down list for the serial port. The default Mode of the serial port is RS232.
- Delimiter1, 2: Click in “Delimiter1, 2” text box and Delimiter1, 2 assigned to the serial port on the Serial Device Server. Check this option to enable Delimiter1, 2. The data will be transmitted if the Delimiter1 is received or Delimiter1 and Delimiter are received.
- Force transmit: Click in “Force transmit” text box and specify Force transmit to the serial port on the Serial Device Server. The data will be transmitted when the Force transmit is reached. The default Force transmit of the serial port is 0 to disable Force transmit.
- Apply the above settings to all serial ports: Check this option to apply the above settings to all serial ports.

Click “Submit” button when you finished Communication Parameters.

Industrial Serial Device Server

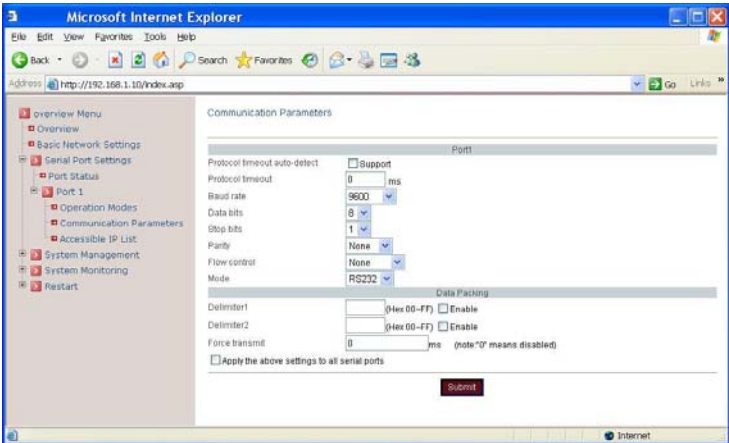

Fig 19. Communication Parameters

6.4. System Management

There are six sections for System Management that includes Server Name Setting, Change Password, E-mail Alert, SNMP Trap, Restore Factory Default, and Firmware Update.

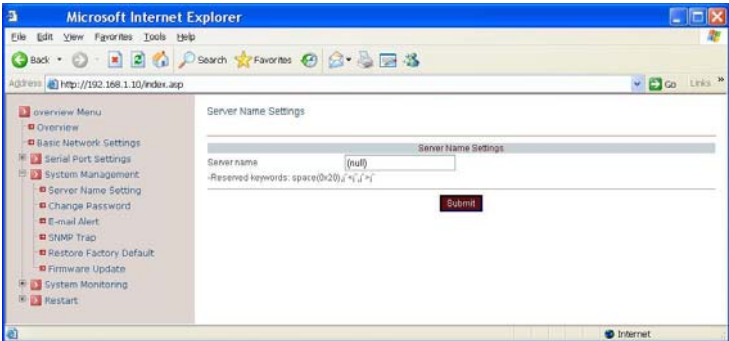

Fig 20. System Management Web Interface

6.4.1. Server Name Setting

- Server name: Click in “Server name” text box and specify Server name to the Serial Device Server.

6.4.3. E-mail Alert

- SMTP Host: SMTP (Simple Mail Transfer Protocol). Click in “SMTP Host” text box and enter IP address of the SMTP Host.
- SMTP Port: Click in “SMTP Port” text box and enter the SMTP Port number. The default SMTP Port number is 25.
- From E-mail address: Click in “From E-mail address” text box and specify the E-mail address to receive the E-mail from.
- E-mail address1 ~ 4: Click in “E-mail address1 ~ 4” text box and specify the E-mail addresses to receive the E-mail. Check this option to enable E-mail address1 ~ 4.

Click “Submit” button when you finished E-mail Alert.

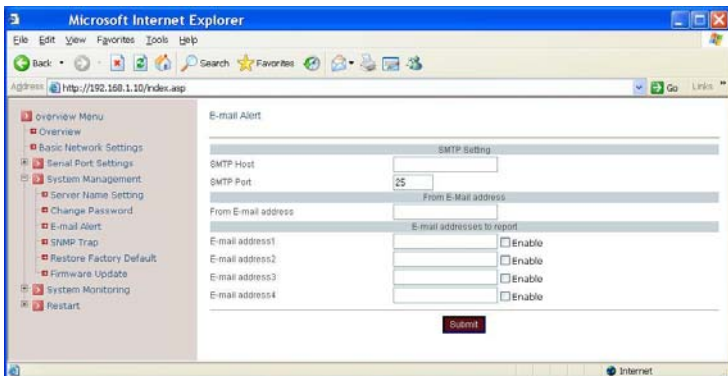

Fig 22. E-mail Alert web page

6.4.4. SNMP Trap

- IP of remote SNMP trap receiver: Click in “IP of remote SNMP trap receiver” text box and enter IP address of the remote SNMP trap receiver.

Click “Submit” button when you finished SNMP Trap.

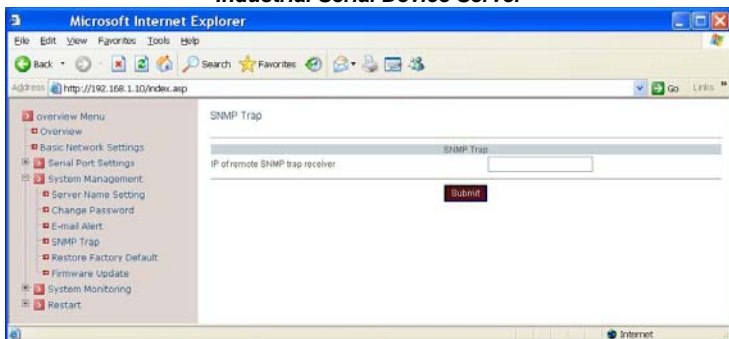

Fig 23. SNMP Trap web page

6.4.5. Restore Factory Default

- Restore factory defaults (all): Check this option to restore the Serial Device Server to the factory default values.
- Restore factory defaults (keep networking settings): Check this option to restore the Serial Device Server to the factory default values but keep networking settings of the Serial Device Server.

Click “Submit” button when you finished Restore Factory Default.

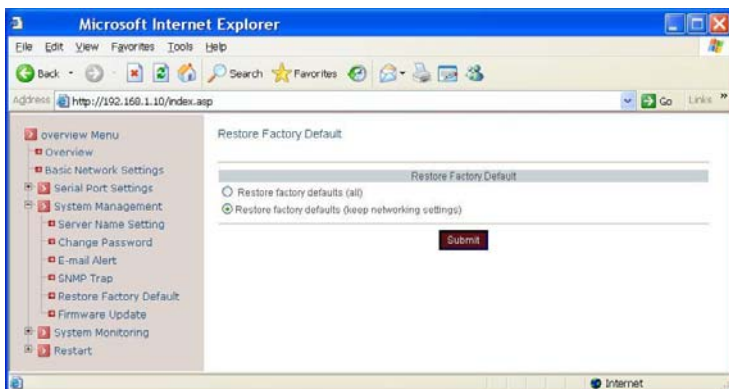

Fig 24. Restore Factory Default web page

6.4.6. Firmware Update

- Select file: Click the “Browser” button to select the firmware and click “Submit” button to update the firmware to the Serial Device Server.

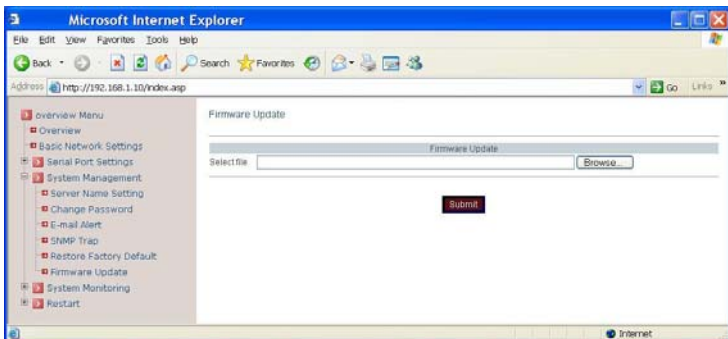

Fig 25. Firmware Update web page

6.5. System Monitoring

There are three sections for System Monitoring that includes Serial to Network Connections, System Log, and Event Log.

6.5.1. Serial to Network Connections

- Serial to Network Connections: View the network connections status of serial port on the Serial Device Server.

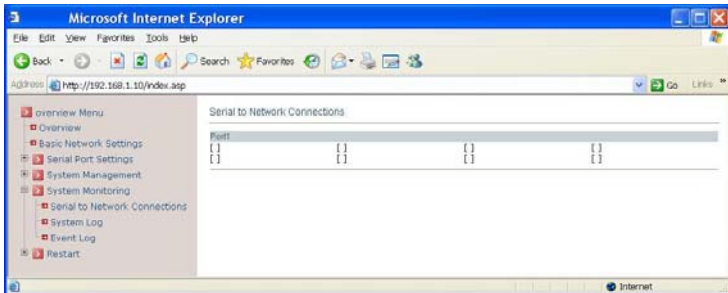

Fig 26. Serial to Network Connections web page

6.5.2. System Log

- System Log: Click the “Reload” button to reload the System Log of the Serial Device Server and click “Clean” button to clean the System Log of the Serial Device Server.

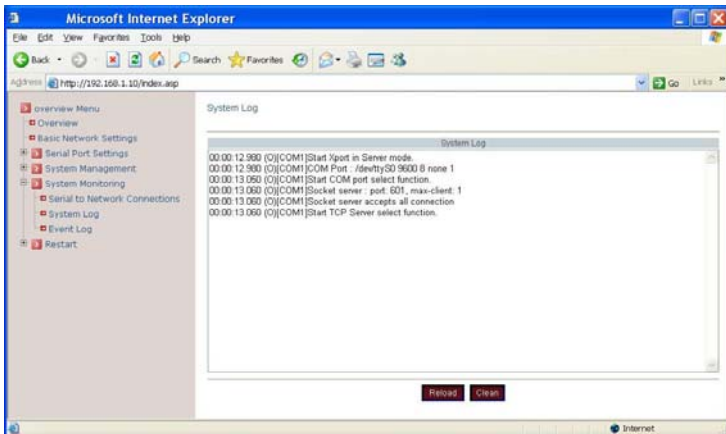

Fig 27. System Log web page

6.5.3. Event Log

- Event Log: Click the “Reload” button to reload the Event Log of the Serial Device Server and click “Clean” button to clean the Event Log of the Serial Device Server.

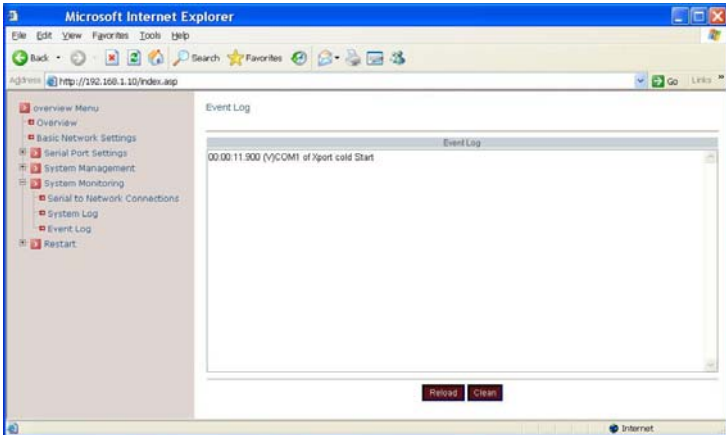

Fig 28. Event Log web page

6.6. Restart

There are two sections for Restart that includes Restart Port and Restart System.

6.6.1. Restart Port

- Select Ports: Check to select the serial port on the Serial Device Server to be restarted.

Click "Submit" button when you finished Restart Port.

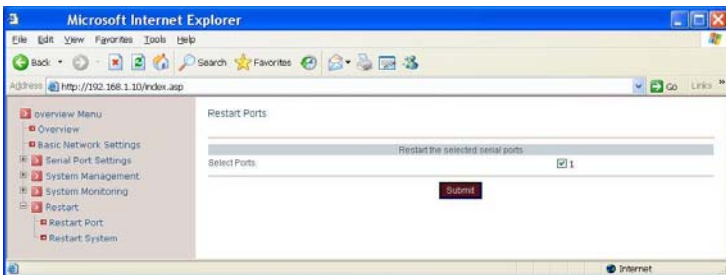

Fig 29. Restart Port web page

6.6.2. Restart System

- Select System: Click the “Restart” button to restart the Serial Device Server.

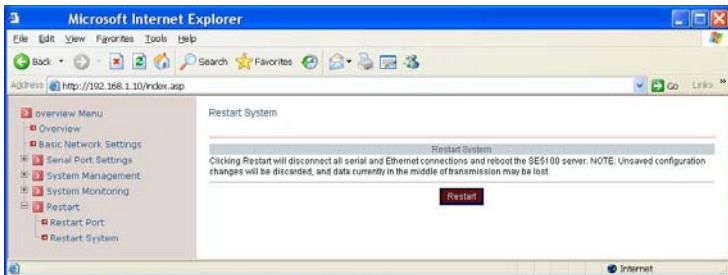

Fig 30. Restart System web page

7. Telnet Configuration

User can also use Telnet utility to change Serial Device Server configuration settings.

- Open Ms-DOS command prompt window or other telnet tools.
- Enter the “IP address” of the Serial Device Server. (Telnet 192.168.1.10).

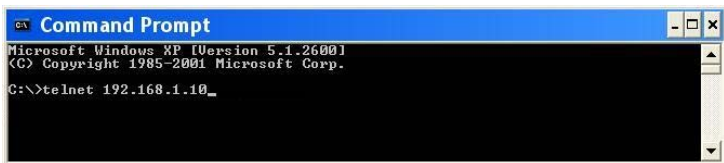

Fig 31. Login into System by Telnet

- The system then prompts for password, the default password is “admin”.



Fig 32. Password to login into System

Then the following main menu shall appear.

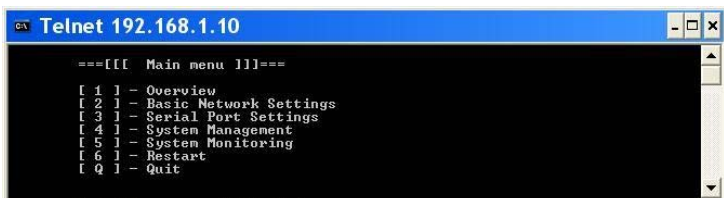

Fig 33. Main menu by telnet

7.1. Overview

Operation: [Main menu] → [1 Overview]

Please choice “1” and press <enter> to enter Overview page.

This system overview window gives the general information of Model Name, Server Name, Serial No, F/W Version, IP Address, MAC Address, Lan Speed, and Up Time for the Serial Device Server (Fig 34).

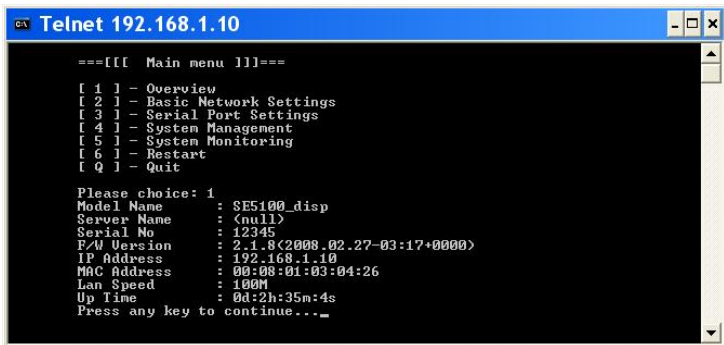

```

Telnet 192.168.1.10

==[[[ Main menu ]]]==

[ 1 ] - Overview
[ 2 ] - Basic Network Settings
[ 3 ] - Serial Port Settings
[ 4 ] - System Management
[ 5 ] - System Monitoring
[ 6 ] - Restart
[ Q ] - Quit

Please choice: 1
Model Name       : SF5100_disp
Server Name      : <null>
Serial No        : 12345
F/W Version      : 2.1.8<2008.02.27-03:17+0000>
IP Address       : 192.168.1.10
MAC Address      : 00:08:01:03:04:26
Lan Speed        : 100M
Up Time          : 0d:2h:35m:4s
Press any key to continue..._
  
```

Fig 34. System Information from Overview

7.2. Basic Network Settings

Operation: [Main menu] → [2 Basic Network Settings]

Please choice “2” and press <enter> to enter Basic Network Settings page.

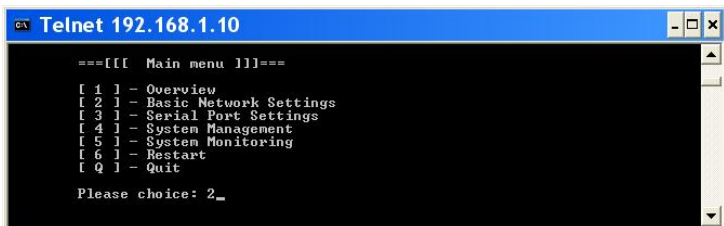

```

Telnet 192.168.1.10

==[[[ Main menu ]]]==

[ 1 ] - Overview
[ 2 ] - Basic Network Settings
[ 3 ] - Serial Port Settings
[ 4 ] - System Management
[ 5 ] - System Monitoring
[ 6 ] - Restart
[ Q ] - Quit

Please choice: 2_
  
```

Fig 35. Basic Network Settings by Telnet

* **Note:** Enter “Q” and press <Enter> to return to the Main

menu.

This section allows for changes in DHCP, IP address, Netmask address, Gateway address, DNS1 address, DNS2 address, DNS3 address, Time Server, Time Area, Year, Month, Day, Hour, Minute, and Second.

7.3. Serial Port Settings

User can configure serial parameters that includes Port Status, Operation Modes, Communication Parameters, and Accessible IP List.

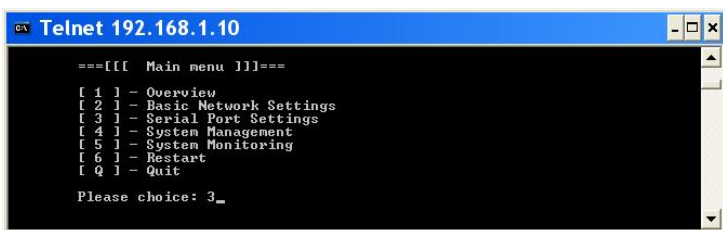

Fig 36. Select Serial Port Settings by Telnet

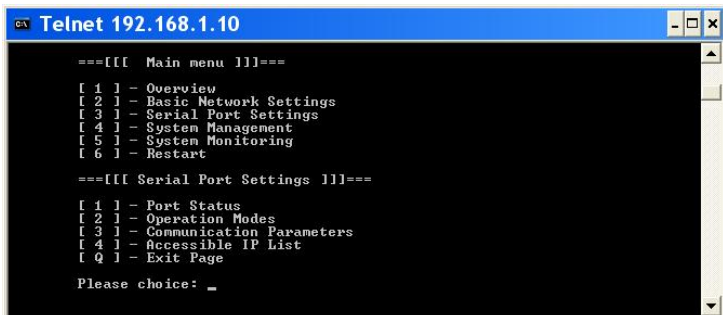

Fig 37. The Serial Port Settings page

7.3.1. Port Status

Operation: [Main menu] → [3 Serial Port Settings] → [1 Port Status]

Industrial Serial Device Server

The Port Name, Device, Parameters, Interface, and Operation Mode as the Fig 38. Port Status screen will appear.

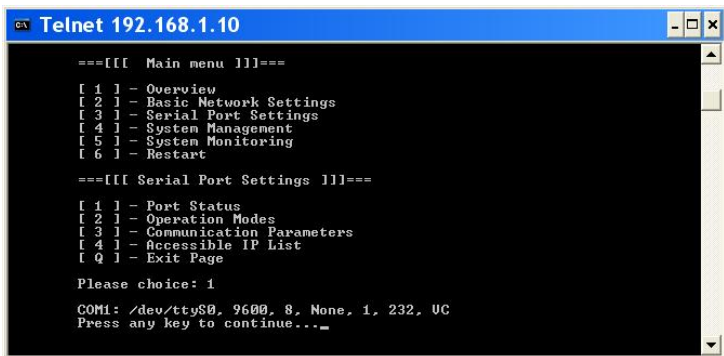

Fig 38. The Port Status page

7.3.2. Operation Modes

Operation: [Main menu] → [3 Serial Port Settings] → [2 Operation Modes]

The Cyber Com, Pair Connection, TCP Server, TCP Client, and UDP as the Fig 40. Operation Modes screen will appear.

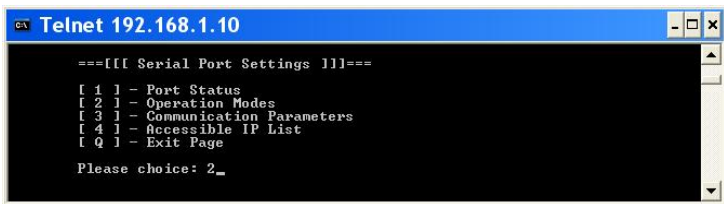

Fig 39. Select Operation Modes by Telnet

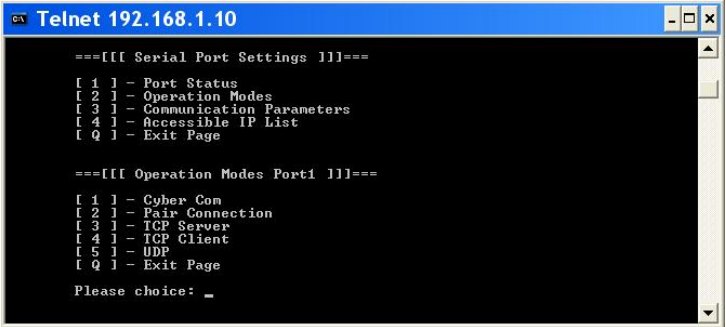

Fig 40. The Operation Modes page

Cyber Com

Operation: [Main menu] → [3 Serial Port Settings] → [2 Operation Modes] → [1 Cyber Com]

- **TCP Port:** Type a TCP Port number assigned to the serial port on the Serial Device Server. The default TCP Port number is 601.
- **RFC2217:** RFC2217 is used to establish a transparent connection between a host computer and a serial device by mapping the serial port on the Serial Device Server to a local COM port on the host computer. Type “y” or “n” to enable or disable RFC2217 for Cyber Com Operation Modes.
- **Set Max Client:** The maximum number of host computers that can receive data from the Serial Device Server simultaneously. Type “1” ~ “8” Max Client for the serial port on the Serial Device Server.

Pair Connection

Operation: [Main menu] → [3 Serial Port Settings] → [2 Operation Modes] → [2 Pair Connection]

- **TCP Port:** Type a TCP Port number assigned to the serial port on the Serial Device Server. The default TCP Port number is 601.
- Type “1” or “2” to select Master or Slave.
- **IP:** Specify the IP address of the Slave Serial Device Server of Pair Connection.

TCP Server

Operation: [Main menu] → [3 Serial Port Settings] → [2 Operation Modes] → [3 TCP Server]

- **TCP Port:** Type a TCP Port number assigned to the serial port on the Serial Device Server. The default TCP Port number is 601.
- **RFC2217:** RFC2217 is used to establish a transparent connection between a host computer and a serial device by mapping the serial port on the Serial Device Server to a local COM port on the host computer. Type “y” or “n” to enable or disable RFC2217 for TCP Server Operation Modes.
- **Set Max Client:** The maximum number of host computers that can receive data from the Serial Device Server simultaneously. Type “1” ~ “8” Max Client for the serial port on the Serial Device Server.

TCP Client

Operation: [Main menu] → [3 Serial Port Settings] → [2 Operation Modes] → [4 TCP Client]

- **RFC2217:** RFC2217 is used to establish a transparent connection between a host computer and a serial device by mapping the serial port on the Serial Device Server to a local COM port on the host computer. Type “y” or “n” to enable or disable RFC2217 for TCP Client Operation Modes.
- **Re-Connect Interval:** Type a period of Re-Connect Interval assigned to the serial port on the Serial Device Server. The connection will be reestablished with other hosts for a defined period of time (Re-Connect Interval). The default Re-Connect Interval is 3 seconds.
- **Connect Timeout:** Type a period of Connect Timeout assigned to the serial port on the Serial Device Server. The connection will be closed and the port will be freed for connection with other hosts when serial port stops data transmission for a defined period of time (Connect Timeout). The default Connect Timeout is 3 seconds.
- **Remote IP1 ~ 8, Remote Port1 ~ 8:** Specify IP addresses and Port numbers of remote host computers.

UDP

Operation: [Main menu] → [3 Serial Port Settings] → [2

Operation Modes] → [5 UDP]

- UDP Port: Type a UDP Port number assigned to the Source UDP Clients. The default UDP Port number is 601.
- Source IP1 ~ 8: Specify IP addresses of Source UDP Clients.
- Server IP1 ~ 8, Server Port1 ~ 8: Specify IP addresses and Port numbers of remote UDP Servers.

7.3.3. Communication Parameters

Operation: [Main menu] → [3 Serial Port Settings] → [3 Communication Parameters]

- Protocol timeout auto-detect: Type “y” or “n” to enable or disable Protocol timeout auto-detect. The Serial Device Server will automatically test the TCP connection to remote host. If the TCP connection is idle, the TCP connection will be closed and the port will be freed for other hosts.
- Set Protocol Timeout: Type a period of Protocol Timeout (0 ~ 99ms) assigned to the serial port on the Serial Device Server. The connection will be closed and the port will be freed for connection with other hosts when serial port stops data transmission for a defined period of time (Protocol Timeout). The default Protocol Timeout is 0ms.
- Baud rate: Select Baud rate 50 ~ 460800bps for the serial port. The default Baud rate of the serial port is 9600bps.
- Data bits: Select Data bits 5, 6, 7, or 8 for the serial port. The default Data bits of the serial port is 8 bits.
- Stop bits: Select Stop bits 1 or 2 for the serial port. The default Stop bits of the serial port is 1 bit.
- Parity: Select Parity None, Odd, Even, Mark, or Space for the serial port. The default Parity of the serial port is None.
- Mode: Select Mode RS232, RS485, or RS422 for the serial port. The default Mode of the serial port is RS232.
- Flow control: Select Flow control None, Hardware, or Software for the serial port. The default Flow control of the serial port is None.
- Delimiter1 Enable: Type “y” or “n” to enable or disable

Industrial Serial Device Server

Delimiter1 for the serial port on the Serial Device Server.

- Set Delimiter1: Type Delimiter1 (Hex 00 ~ FF) to the serial port on the Serial Device Server.
- Delimiter2 Enable: Type “y” or “n” to enable or disable Delimiter2 for the serial port on the Serial Device Server.
- Set Delimiter2: Type Delimiter2 (Hex 00 ~ FF) to the serial port on the Serial Device Server.
- Set ForceTransmit: Specify Force transmit to the serial port on the Serial Device Server. The data will be transmitted when the Force transmit is reached. The default Force transmit of the serial port is 0 to disable Force transmit.

7.3.4. Accessible IP List

Operation: [Main menu] → [3 Serial Port Settings] → [4 Accessible IP List]

- Enable the accessible IP list: Type “y” or “n” to enable or disable the accessible IP list. Disable will allow all IP’s connection request.
- Accessible IP Enable1 ~ 8: Type “y” or “n” to enable or disable IP addresses that can access to the serial port on the Serial Device Server.
- Accessible IP1 ~ 8: Specify IP addresses that can access to the serial port on the Serial Device Server.

7.4. System Management

User can configure System Management that includes Server Name Setting, Change Password, E-mail Alert, SNMP Trap, and Restore Factory Default.

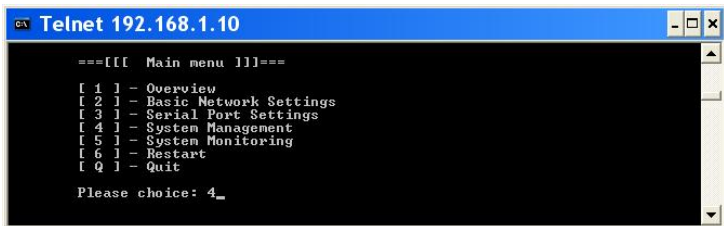

```
Telnet 192.168.1.10
===[[[ Main menu ]]]===
[ 1 ] - Overview
[ 2 ] - Basic Network Settings
[ 3 ] - Serial Port Settings
[ 4 ] - System Management
[ 5 ] - System Monitoring
[ 6 ] - Restart
[ 7 ] -
[ 8 ] -
[ 9 ] -
[ Q ] - Quit
Please choice: 4_
```

Fig 41. Select System Management by Telnet

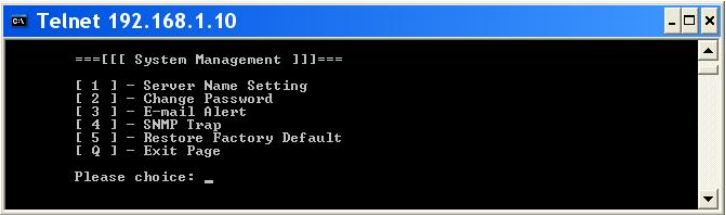

Fig 42. The System Management page

7.4.1. Server Name Setting

Operation: [Main menu] → [4 System Management] → [1 Server Name Setting]

- Set Server Name: Specify Server Name to the Serial Device Server.

7.4.2. Change Password

Operation: [Main menu] → [4 System Management] → [2 Change Password]

- Old password: Enter the Old password of the Serial Device Server.
- New password: Enter the New password for the Serial Device Server.
- Again: Enter the New password again for the Serial Device Server.

7.4.3. E-mail Alert

Operation: [Main menu] → [4 System Management] → [3 E-mail Alert]

- SMTP Host: SMTP (Simple Mail Transfer Protocol). Enter IP address of the SMTP Host.
- SMTP Port: Enter the SMTP Port number. The default SMTP Port number is 25.
- From E-mail address: Specify the E-mail address to

Industrial Serial Device Server

receive the E-mail from.

- E-mail address1 ~ 4: Type “y” or “n” to enable or disable the E-mail addresses to receive the E-mail.
- Mail 1 ~ 4 address: Specify the E-mail addresses to receive the E-mail.

7.4.4. SNMP Trap

Operation: [Main menu] → [4 System Management] → [4 SNMP Trap]

- IP of remote SNMP trap receiver: Enter IP address of the remote SNMP trap receiver.

7.4.5. Restore Factory Default

Operation: [Main menu] → [4 System Management] → [5 Restore Factory Default]

- Restore factory defaults (keep networking settings): Type “y” or “n” to enable or disable restoration the Serial Device Server to the factory default values but keep networking settings of the Serial Device Server.
- Restore factory defaults (all): Type “y” or “n” to enable or disable restoration the Serial Device Server to the factory default values.

7.5. System Monitoring

User can configure System Monitoring that includes Serial to Network Connections, System Log, and Event Log.

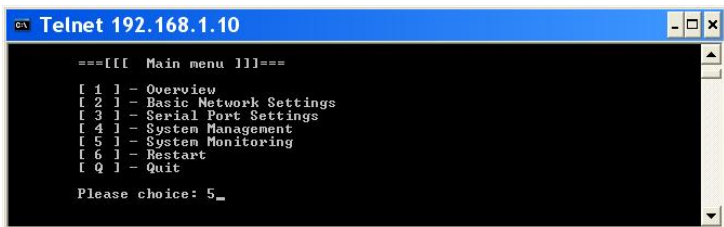

Fig 43. Select System Monitoring by Telnet

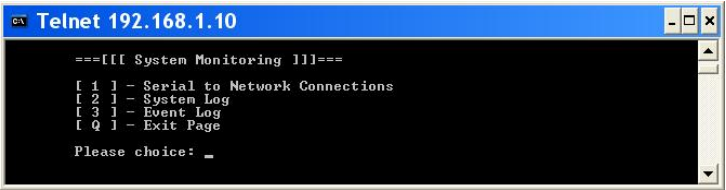

Fig 44. The System Monitoring page

7.5.1. Serial to Network Connections

Operation: [Main menu] → [5 System Monitoring] → [1 Serial to Network Connections]

- Serial to Network Connections: View the network connections status of serial port on the Serial Device Server.

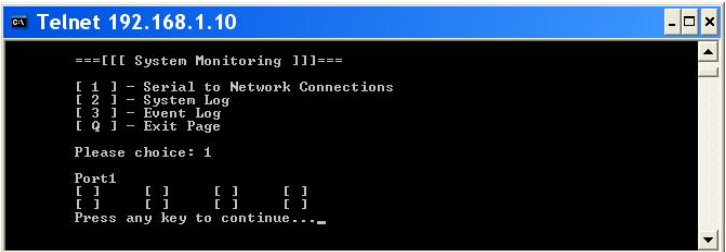

Fig 45. The Serial to Network Connections page

7.5.2. System Log

Operation: [Main menu] → [5 System Monitoring] → [2 System Log]

- Serial to Network Connections: View the System Log of serial port on the Serial Device Server.

```

Telnet 192.168.1.10

===[[[ System Monitoring ]]]===

[ 1 ] - Serial to Network Connections
[ 2 ] - System Log
[ 3 ] - Event Log
[ Q ] - Exit Page

Please choice: 2
00:00:24.610 (<)ICOMI Start Xport in Server mode.
00:00:24.620 (<)ICOMI COM Port : /dev/ttyS0 9600 8 none 1
00:00:24.730 (<)ICOMI Start COM port select function.
00:00:24.730 (<)ICOMI Socket server : port: 601, max-client: 1
00:00:24.730 (<)ICOMI Socket server accepts all connection
00:00:24.740 (<)ICOMI Start TCP Server select function.
00:04:14.280 (<)ICOMI Stop Xport.
00:04:14.980 (<)ICOMI Start Xport in UC mode.
00:04:14.990 (<)ICOMI COM Port : /dev/ttyS0 9600 8 none 1
00:04:15.030 (<)ICOMI Start COM port select function.
00:04:15.040 (<)ICOMI Socket server : port: 601, max-client: 1
00:04:15.040 (<)ICOMI Socket server accepts all connection
00:04:15.040 (<)ICOMI Start TCP Server select function.
13:49:37.090 (<)ICOMI Stop Xport.
13:49:37.780 (<)ICOMI Start Xport in UC mode.
13:49:37.790 (<)ICOMI COM Port : /dev/ttyS0 9600 8 none 1
13:49:37.840 (<)ICOMI Socket server : port: 601, max-client: 1
13:49:37.850 (<)ICOMI Socket server accepts all connection
13:49:37.850 (<)ICOMI Start TCP Server select function.
13:49:37.850 (<)ICOMI Start COM port select function.
Press any key to continue..._

```

Fig 46. The System Log page

7.5.3. Event Log

Operation: [Main menu] → [5 System Monitoring] → [3 Event Log]

- Serial to Network Connections: View the Event Log of serial port on the Serial Device Server.

```

Telnet 192.168.1.10

===[[[ System Monitoring ]]]===

[ 1 ] - Serial to Network Connections
[ 2 ] - System Log
[ 3 ] - Event Log
[ Q ] - Exit Page

Please choice: 3
00:00:22.160 (<)COM1 of Xport cold Start
00:04:14.290 (<)COM1 of Xport warm Start
13:49:37.100 (<)COM1 of Xport warm Start
Press any key to continue..._

```

Fig 47. The Event Log page

7.6. Restart

User can configure Restart that includes Restart Port and Restart System.



Fig 48. Select Restart by Telnet

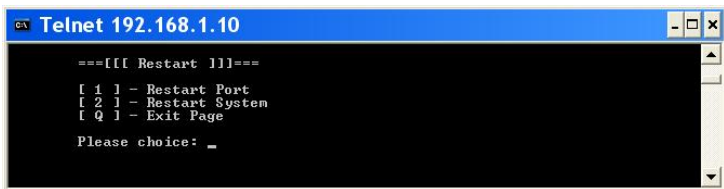

Fig 49. The Restart page

7.6.1. Restart Port

Operation: [Main menu] → [6 Restart] → [1 Restart Port]

- Restart all Port: Type “y” or “n” to enable or disable all the serial port on the Serial Device Server to be restarted.

7.6.2. Restart System

Operation: [Main menu] → [6 Restart] → [1 Restart System]

- Are you sure: Type “y” or “n” to enable or disable the Serial Device Server to be restarted.

8. Xport Utility

8.1. Xport Utility Introduction

Xport Utility is a tool for device management and configuration, and can realize the daily management on various network devices for address search, device positioning, parameter configuring, firmware downloading and so on.

8.2. Interface

The operating interface of the Xport utility shown as below:

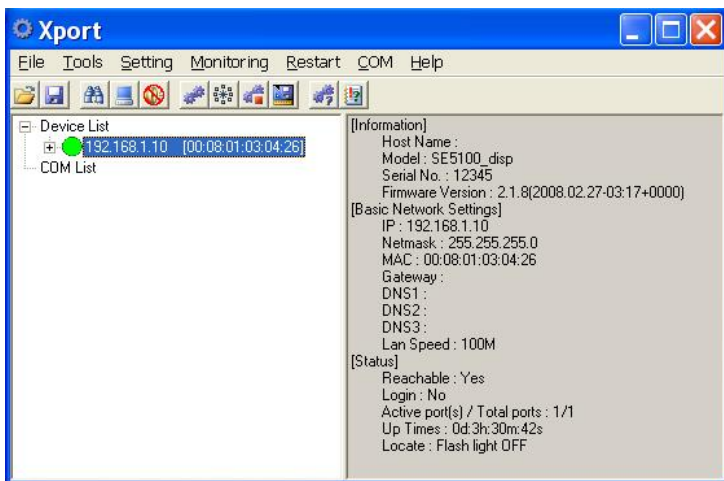

Fig 50. The operating interface of the Xport utility

8.3. Device List

8.3.1. Login to System by Web Interface

User can double click on the IP address of the Serial Device Server to login to Serial Device Server by web interface.

Industrial Serial Device Server

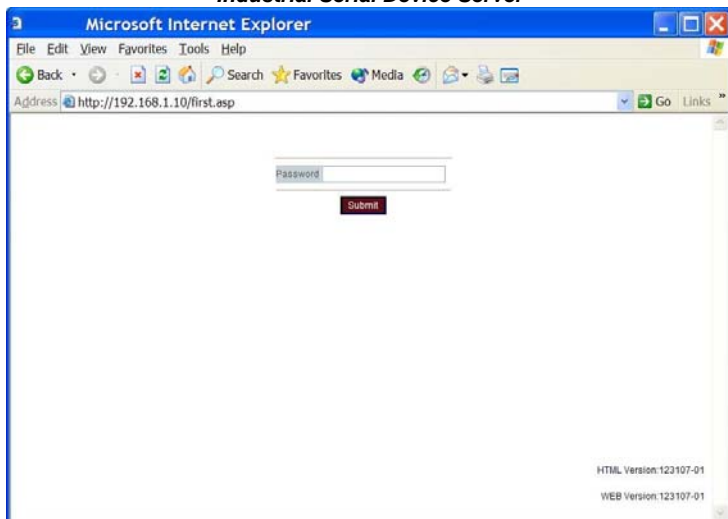

Fig 50. Login to System by Web Interface

8.3.2. Functions

User can click right button of mouse on the IP address of the Serial Device Server to show functions as Fig 51.

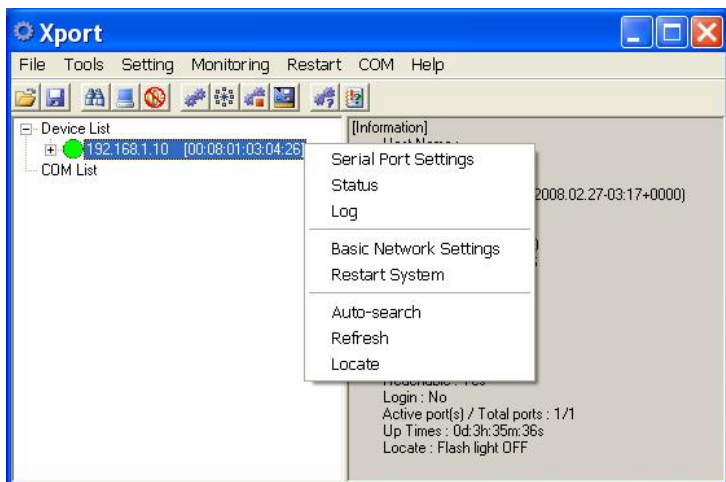

Fig 51. Functions

8.3.3. Serial port

User can click right button of mouse on the serial port of the Serial Device Server to show as Fig 52.

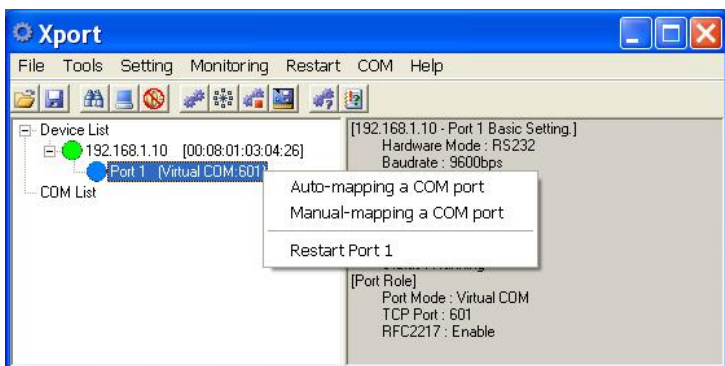

Fig 52. Serial port

Auto-mapping a COM port

User can use the Xport utility to automatically map a serial port to a COM port on a PC. The serial port on the Serial Device Server has to be set to Virtual Com mode when mapping COM port with Xport utility.

1. Map successfully: The serial port on the Serial Device Server has been successfully mapped to a COM port on a PC.

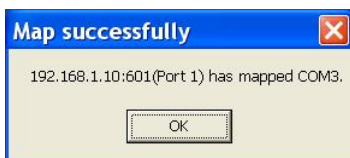

Fig 53. Auto-mapping a COM port

2. COM List: Click right button of mouse on the COM port to show as Fig 54.

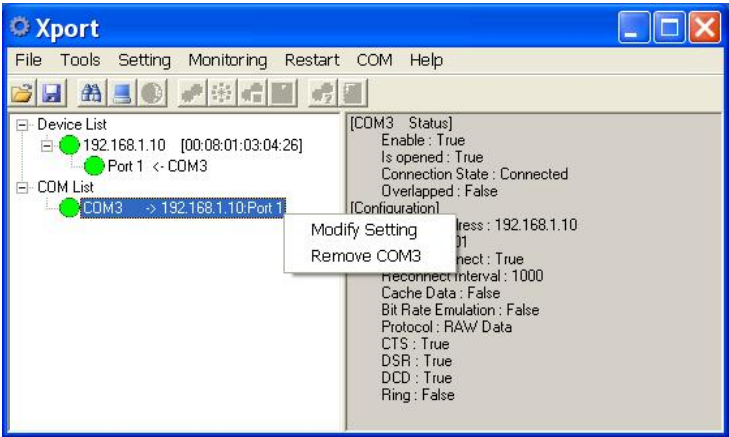

Fig 54. COM List

3. Modify Setting: User can modify Network setting and Serial setting of COM port settings as Fig 55. and Fig 56.

- Network setting:

Remote IP address: Input the IP address of the remote Serial Device Server.

TCP port: Choose TCP port number assigned to the COM port. The default TCP port number is 601.

Active auto-reconnect: Check this option to support Active auto-reconnect. The Xport utility will automatically attempt to reconnect COM port to the serial port on the Serial Device Server.

Reconnect interval: The Xport utility will automatically attempt to reconnect COM port to the serial port on the Serial Device Server in defined time interval (Reconnect interval). The default Reconnect interval is 1000ms.

Cache data when connection was broken: Check this option to ensure that data is buffered if the connection is broken.

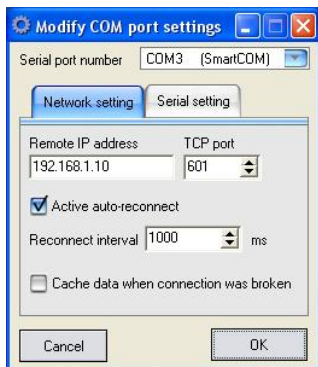

Fig 55. Network setting

- **Serial setting:**

Serial port protocol: Choose Raw protocol or RFC2217 protocol.

Serial port preset signals: There are CTS, DSR, DCD, and RING serial port preset signals that can be chosen.

Enable bitrate emulation: Check this option to limit data transmission speed to that was specified to serial port. Transmission speed depends on bandwidth of the serial connection if bitrate emulation is disabled.

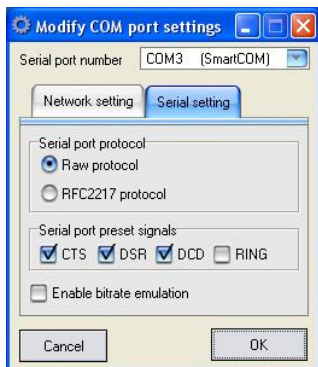

Fig 56. Serial setting

Industrial Serial Device Server

4. Remove COM port: Remove the COM port and remove mapping the serial port to a COM port on a PC.

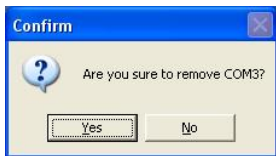

Fig 57. Serial setting

Manual-mapping a COM port

User can use the Xport utility to manually map a serial port to a COM port on a PC. The serial port on the Serial Device Server has to be set to Virtual Com mode when mapping COM port with Xport utility.

1. Network setting:
 - TCP port: Choose TCP port number assigned to the COM port. The default TCP port number is 601.
 - Active auto-reconnect: Check this option to support Active auto-reconnect. The Xport utility will automatically attempt to reconnect COM port to the serial port on the Serial Device Server.
 - Reconnect interval: The Xport utility will automatically attempt to reconnect COM port to the serial port on the Serial Device Server in defined time interval (Reconnect interval). The default Reconnect interval is 1000ms.
 - Cache data when connection was broken: Check this option to ensure that data is buffered if the connection is broken.

Industrial Serial Device Server

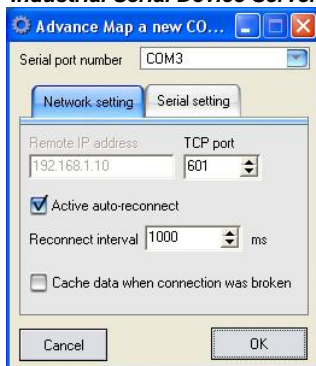

Fig 58. Network setting

2. Serial setting:

- Serial port protocol: Choose Raw protocol or RFC2217 protocol.
- Serial port preset signals: There are CTS, DSR, DCD, and RING serial port preset signals that can be chosen.
- Enable bitrate emulation: Check this option to limit data transmission speed to that was specified to serial port. Transmission speed depends on bandwidth of the serial connection if bitrate emulation is disabled.

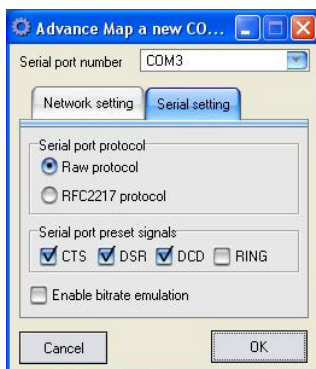

Fig 59. Serial setting

Restart port

Click "Restart port" to restart serial port on the Serial Device Server.

8.3.4. COM List

Click right button of mouse on the COM List to show as Fig 54.

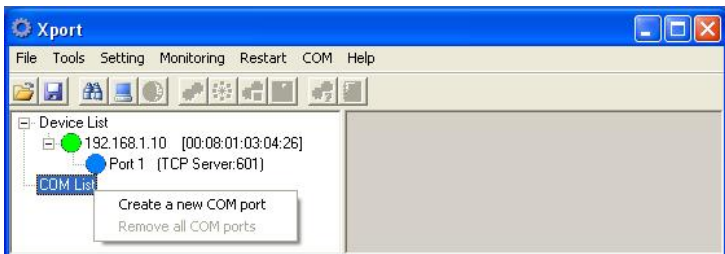

Fig 60. COM List

Create a new COM port

User can use the Xport utility to map a serial port to a COM port on a PC. The serial port on the Serial Device Server has to be set to Virtual Com mode when mapping COM port with Xport utility.

1. Network setting:
 - TCP port: Choose TCP port number assigned to the COM port. The default TCP port number is 601.
 - Active auto-reconnect: Check this option to support Active auto-reconnect. The Xport utility will automatically attempt to reconnect COM port to the serial port on the Serial Device Server.
 - Reconnect interval: The Xport utility will automatically attempt to reconnect COM port to the serial port on the Serial Device Server in defined time interval (Reconnect interval). The default Reconnect interval is 1000ms.
 - Cache data when connection was broken: Check this option to ensure that data is buffered if the connection is broken.

Industrial Serial Device Server

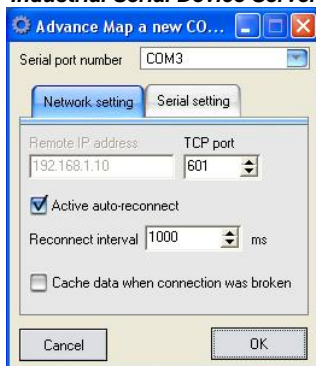

Fig 61. Network setting

2. Serial setting:

- Serial port protocol: Choose Raw protocol or RFC2217 protocol.
- Serial port preset signals: There are CTS, DSR, DCD, and RING serial port preset signals that can be chosen.
- Enable bitrate emulation: Check this option to limit data transmission speed to that was specified to serial port. Transmission speed depends on bandwidth of the serial connection if bitrate emulation is disabled.

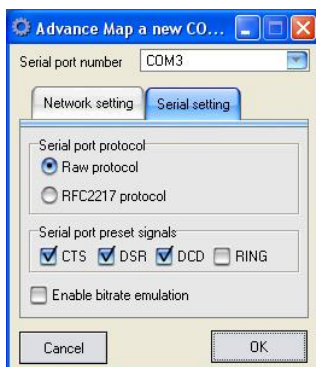

Fig 62. Serial setting

Remove all COM ports

Click "Remove all COM ports" to remove all the COM ports and remove all the mapping from the serial ports to COM

ports on a PC.

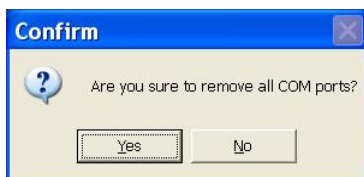

Fig 63. Remove all COM ports

8.4. File

Click "File" from menu bar to show as Fig 64.

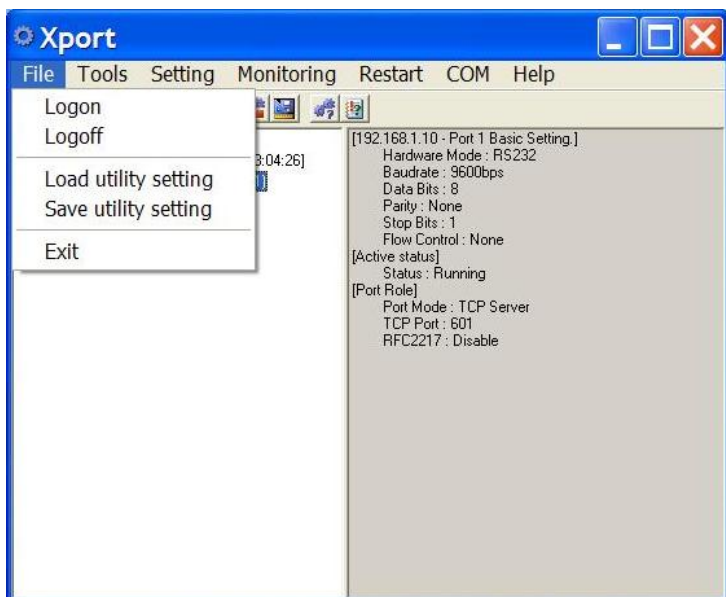

Fig 64. File

8.4.1. Logon

Click "Logon" from "File" to show the authentication screen as Fig 64. Enter password then click on "OK" button to logon to

Industrial Serial Device Server

the Serial Device Server. The default password is “admin”.



Fig 64. Logon

8.4.2. Logoff

Click “Logoff” from “File” to logoff from the Serial Device Server.

8.4.3. Load utility setting

Click “Load utility setting” from “File” to load utility setting file to the Serial Device Server.

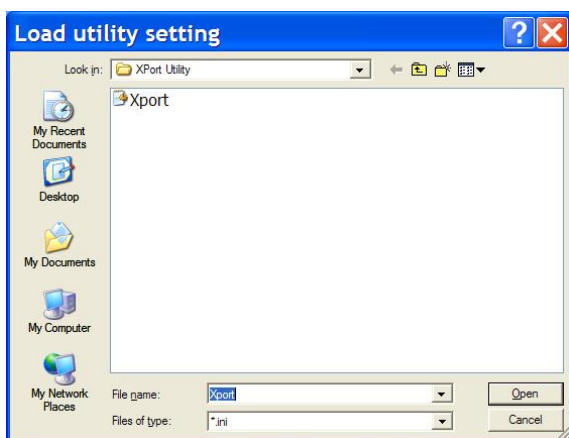

Fig 65. Load utility setting

8.4.4. Save utility setting

Click “Save utility setting” from “File” to save utility setting file from the Serial Device Server.

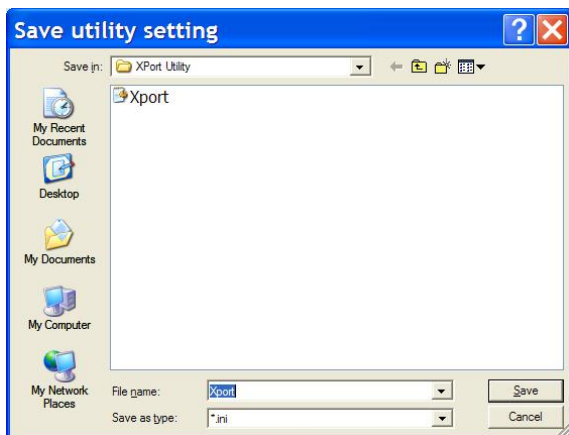

Fig 66. Save utility setting

8.4.5. Exit

Click “Exit” from “File” to exit from Xport utility.

8.5. Tools

Click “Tools” from menu bar to show as Fig 67.

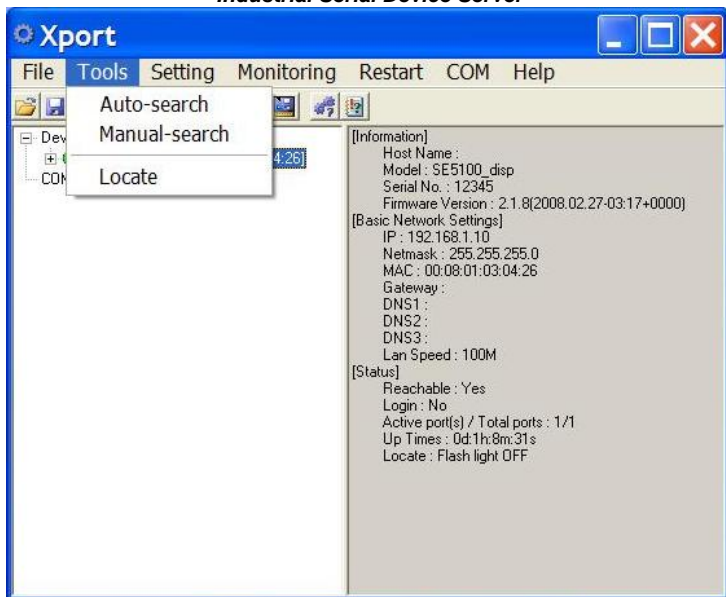

Fig 67. Tools

8.5.1. Auto-search

Click “Auto-search” from “Tools” to search all Serial Device Servers connected to the same LAN as your host PC.

8.5.2. Manual-search

Click “Manual-search” from “Tools” to search all Serial Device Servers in a range of IP addresses.



Fig 68. Manual-search

8.5.3. Locate

The user can apply this function to locate a Serial Device Server. The flash LED of the Serial Device Server will light on if the Serial Device Server is located.

8.6. Setting

Click “Setting” from menu bar to show as Fig 69.

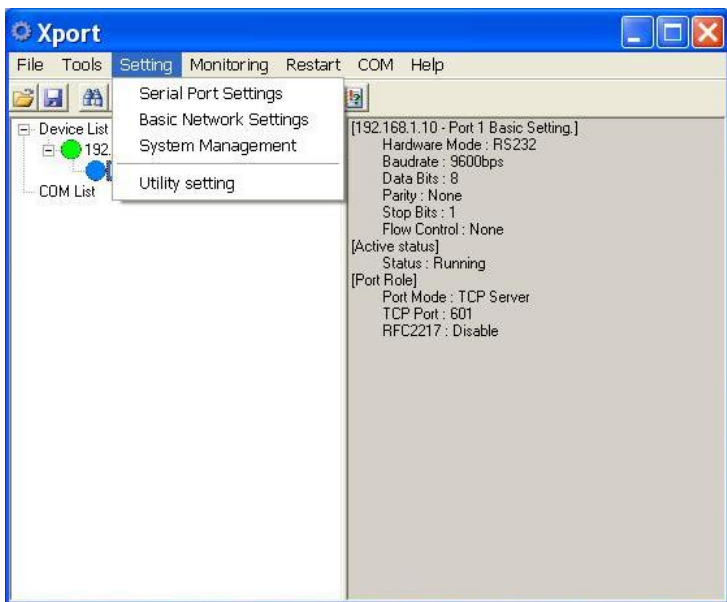

Fig 69. Setting

8.6.1. Serial Port Settings

Click “Serial Port Settings” from “Setting” to configure the serial port of the Serial Device Server.

Industrial Serial Device Server

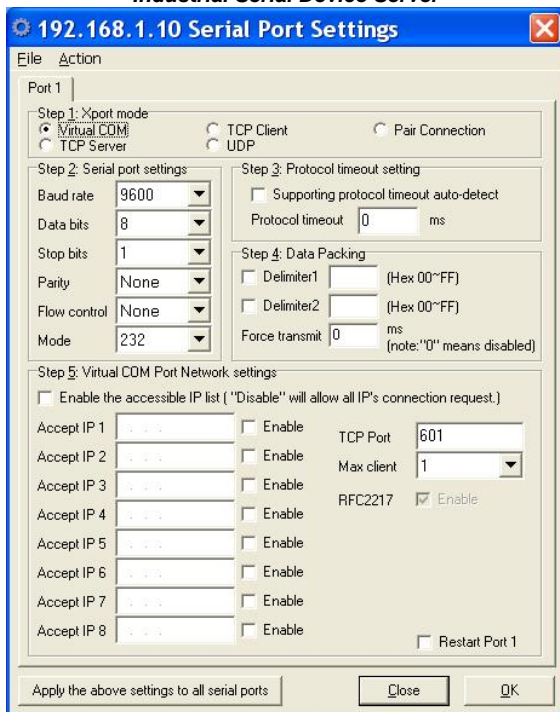

Fig 70. Serial Port Settings

File

Click "File" from menu bar to show as Fig 71.

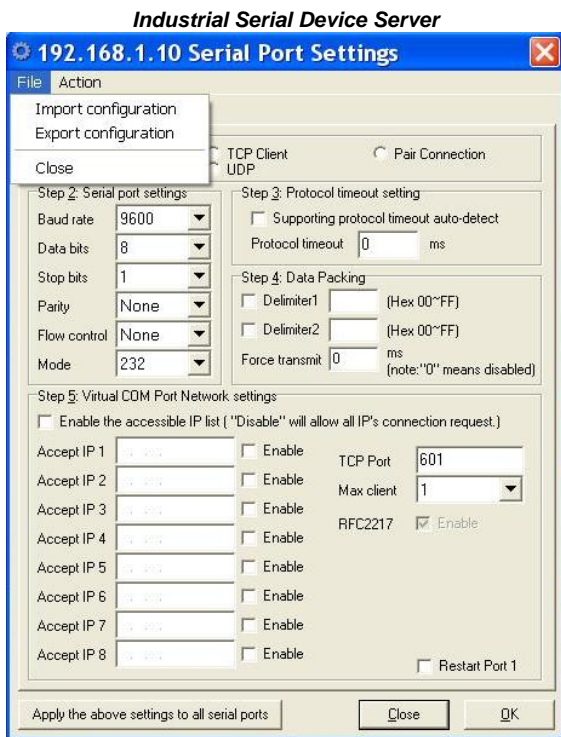

Fig 71. File

1. Import Configuration

Click “Import Configuration” from “File” to import configuration file to the Serial Device Server.

Industrial Serial Device Server

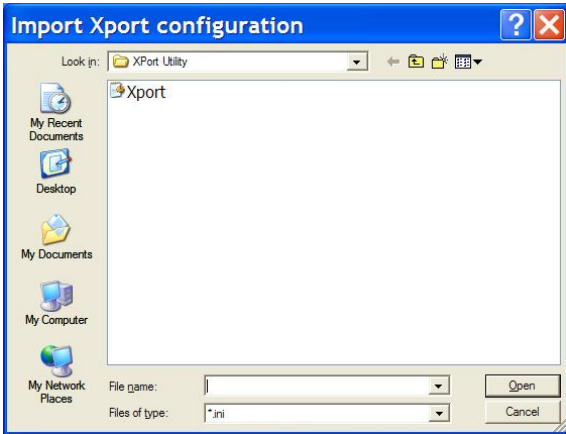

Fig 72. Import Configuration

2. Export Configuration

Click “Export Configuration” from “File” to export configuration file from the Serial Device Server.

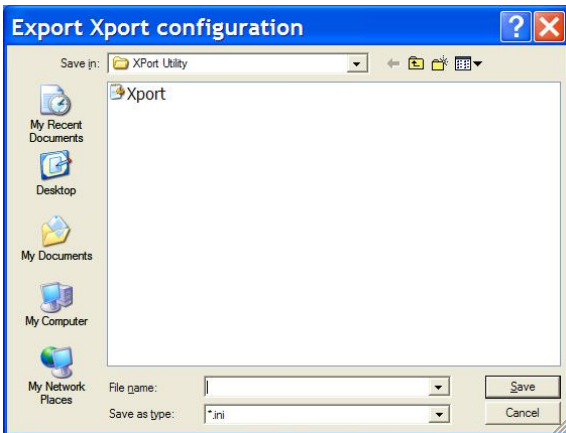

Fig 73. Export Configuration

3. Close

Click “Close” from “File” to exit from “Serial Port Settings” to the Serial Device Server.

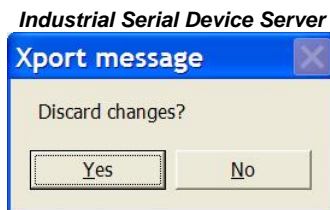

Fig 74. Close

Action

Click "Action" from menu bar to show as Fig 75.

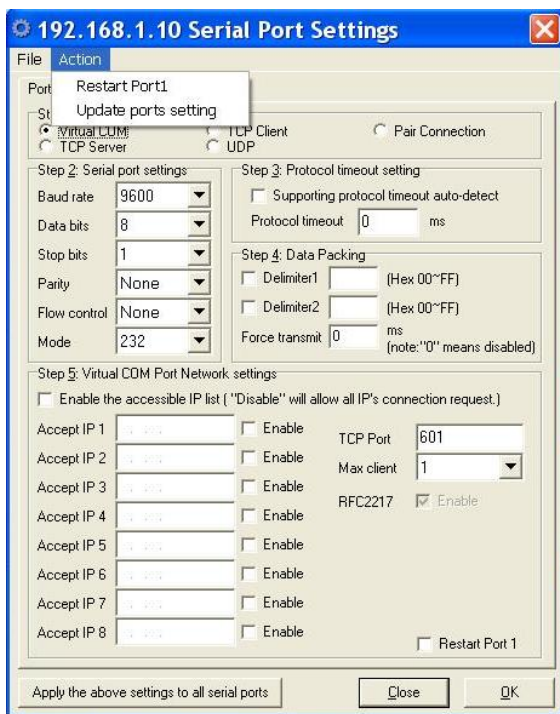

Fig 75. Action

1. Restart Port

Click "Restart Port" from "Action" to restart the serial port on the Serial Device Server.

2. Update ports setting

Industrial Serial Device Server

Click “Update ports setting” from “Action” to update the settings of serial port on the Serial Device Server.

Port

1. Virtual COM

- Step 1: Xport mode

Choose “Virtual Com” from the “Step 1: Xport mode”.

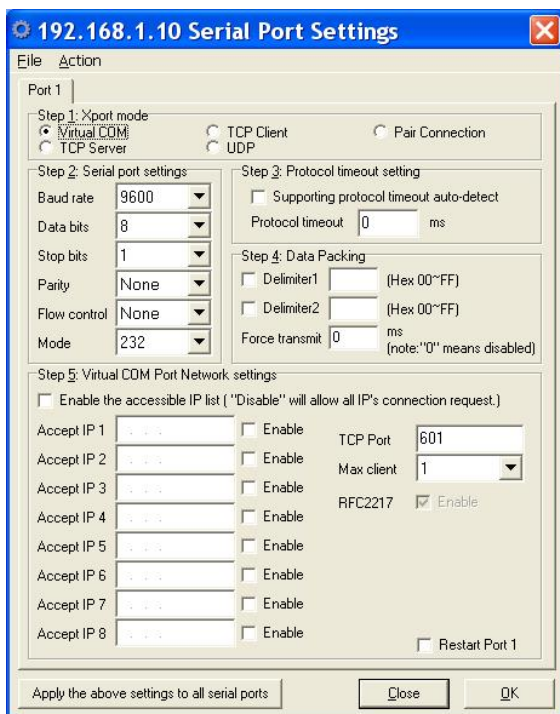

Fig 76. Virtual COM

- Step 2: Serial port settings

Baud rate: Click “Baud rate” drop-down menu to select Baud rate 50 ~ 460800bps from the “Baud rate” drop-down list for the serial port. The default Baud rate of the serial port is 9600bps.

Data bits: Click “Data bits” drop-down menu to select Data

Industrial Serial Device Server

bits 5, 6, 7, or 8 from the “Data bits” drop-down list for the serial port. The default Data bits of the serial port is 8 bits.

Stop bits: Click “Stop bits” drop-down menu to select Stop bits 1 or 2 from the “Stop bits” drop-down list for the serial port. The default Stop bits of the serial port is 1 bit.

Parity: Click “Parity” drop-down menu to select Parity None, Even, Odd, Mark, or Space from the “Parity” drop-down list for the serial port. The default Parity of the serial port is None.

Flow control: Click “Flow control” drop-down menu to select Flow control None, Hardware, or Software from the “Flow control” drop-down list for the serial port. The default Flow control of the serial port is None.

Mode: Click “Mode” drop-down menu to select Mode RS232, RS422, or RS485 from the “Mode” drop-down list for the serial port. The default Mode of the serial port is RS232.

- Step 3: Protocol timeout setting

Support protocol timeout auto-detect: Check this option to support protocol timeout auto-detect. The Serial Device Server will automatically test the TCP connection to remote host. If the TCP connection is idle, the TCP connection will be closed and the port will be freed for other hosts.

Protocol timeout: Click in “Protocol timeout” text box and type a period of Protocol timeout assigned to the serial port on the Serial Device Server. The connection will be closed and the port will be freed for connection with other hosts when serial port stops data transmission for a defined period of time (Protocol timeout). The default Protocol timeout is 0ms.

- Step 4: Data Packing

Delimiter1, 2: Check this option to enable Delimiter1, 2. Click in “Delimiter1, 2” text box and Delimiter1, 2 assigned to the serial port on the Serial Device Server. The data will be transmitted if the Delimiter1 is received or Delimiter1 and Delimiter are received.

Industrial Serial Device Server

Force transmit: Click in “Force transmit” text box and specify Force transmit to the serial port on the Serial Device Server. The data will be transmitted when the Force transmit is reached. The default Force transmit of the serial port is 0 to disable Force transmit.

- Step 5: Virtual COM Port Network settings

Enable the accessible IP list: Check this option to enable the accessible IP list. Disable will allow all IP’s connection request.

Accept IP 1 ~ 8: Click in “Accept IP 1 ~ 8” text box and specify Accept IP addresses that can access to the serial port on the Serial Device Server. Check this option to enable the Accept IP addresses.

TCP Port: Click in “TCP Port” text box and type a TCP Port number assigned to the serial port on the Serial Device Server. The default TCP Port number is 601.

Max client: The maximum number of host computers that can receive data from the Serial Device Server simultaneously. Click “Max client” drop-down menu to select 1 ~ 8 from the “Max client” drop-down list.

RFC2217: RFC2217 is used to establish a transparent connection between a host computer and a serial device by mapping the serial port on the Serial Device Server to a local COM port on the host computer. RFC2217 is always enabled for Virtual Com Mode Setting.

Restart Port: Check this option to restart the serial port on the Serial Device Server when you click the “OK” button to finish Virtual Com Mode Setting.

Apply the above settings to all serial ports: Click this button to apply the above settings to all serial ports.

2. TCP Server

- Step 1: Xport mode

Choose “TCP Server” from the “Step 1: Xport mode”.

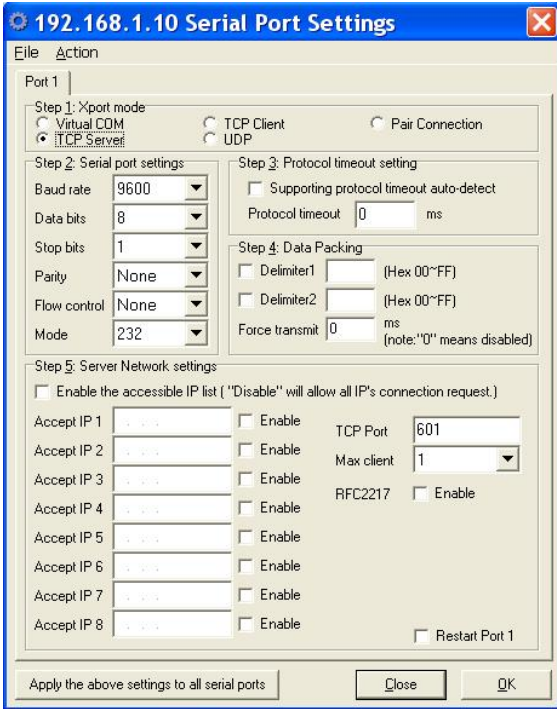

Fig 77. TCP Server

- Step 2: Serial port settings

Baud rate: Click “Baud rate” drop-down menu to select Baud rate 50 ~ 460800bps from the “Baud rate” drop-down list for the serial port. The default Baud rate of the serial port is 9600bps.

Data bits: Click “Data bits” drop-down menu to select Data bits 5, 6, 7, or 8 from the “Data bits” drop-down list for the serial port. The default Data bits of the serial port is 8 bits.

Stop bits: Click “Stop bits” drop-down menu to select Stop bits 1 or 2 from the “Stop bits” drop-down list for the serial port. The default Stop bits of the serial port is 1 bit.

Industrial Serial Device Server

Parity: Click “Parity” drop-down menu to select Parity None, Even, Odd, Mark, or Space from the “Parity” drop-down list for the serial port. The default Parity of the serial port is None.

Flow control: Click “Flow control” drop-down menu to select Flow control None, Hardware, or Software from the “Flow control” drop-down list for the serial port. The default Flow control of the serial port is None.

Mode: Click “Mode” drop-down menu to select Mode RS232, RS422, or RS485 from the “Mode” drop-down list for the serial port. The default Mode of the serial port is RS232.

- Step 3: Protocol timeout setting

Support protocol timeout auto-detect: Check this option to support protocol timeout auto-detect. The Serial Device Server will automatically test the TCP connection to remote host. If the TCP connection is idle, the TCP connection will be closed and the port will be freed for other hosts.

Protocol timeout: Click in “Protocol timeout” text box and type a period of Protocol timeout assigned to the serial port on the Serial Device Server. The connection will be closed and the port will be freed for connection with other hosts when serial port stops data transmission for a defined period of time (Protocol timeout). The default Protocol timeout is 0ms.

- Step 4: Data Packing

Delimiter1, 2: Check this option to enable Delimiter1, 2. Click in “Delimiter1, 2” text box and Delimiter1, 2 assigned to the serial port on the Serial Device Server. The data will be transmitted if the Delimiter1 is received or Delimiter1 and Delimiter are received.

Force transmit: Click in “Force transmit” text box and specify Force transmit to the serial port on the Serial Device Server. The data will be transmitted when the Force transmit is reached. The default Force transmit of the serial port is 0 to disable Force transmit.

- Step 5: Server Network settings

Industrial Serial Device Server

Enable the accessible IP list: Check this option to enable the accessible IP list. Disable will allow all IP's connection request.

Accept IP 1 ~ 8: Click in "Accept IP 1 ~ 8" text box and specify Accept IP addresses that can access to the serial port on the Serial Device Server. Check this option to enable the Accept IP addresses.

TCP Port: Click in "TCP Port" text box and type a TCP Port number assigned to the serial port on the Serial Device Server. The default TCP Port number is 601.

Max client: The maximum number of host computers that can receive data from the Serial Device Server simultaneously. Click "Max client" drop-down menu to select 1 ~ 8 from the "Max client" drop-down list.

RFC2217: RFC2217 is used to establish a transparent connection between a host computer and a serial device by mapping the serial port on the Serial Device Server to a local COM port on the host computer. Check this option to enable RFC2217 for TCP Server Setting.

Restart Port: Check this option to restart the serial port on the Serial Device Server when you click the "OK" button to finish TCP Server Setting.

Apply the above settings to all serial ports: Click this button to apply the above settings to all serial ports.

3. TCP Client

- Step 1: Xport mode

Choose "TCP Client" from the "Step 1: Xport mode".

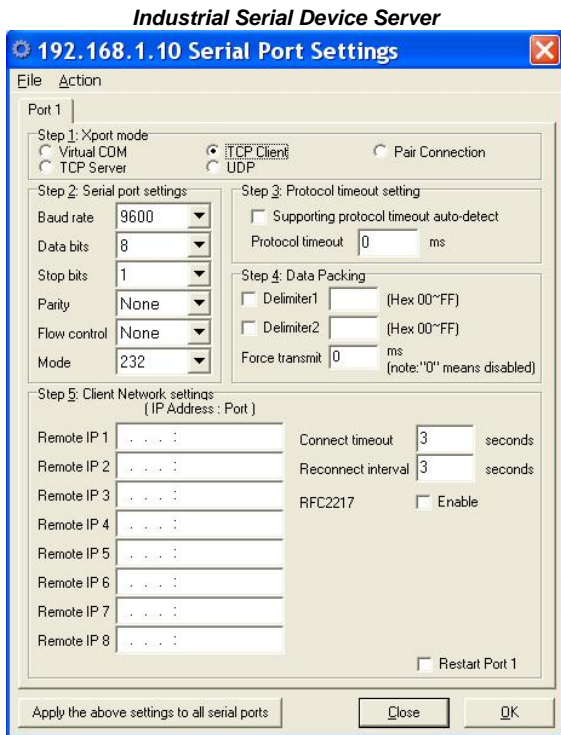

Fig 78. TCP Client

- Step 2: Serial port settings

Baud rate: Click “Baud rate” drop-down menu to select Baud rate 50 ~ 460800bps from the “Baud rate” drop-down list for the serial port. The default Baud rate of the serial port is 9600bps.

Data bits: Click “Data bits” drop-down menu to select Data bits 5, 6, 7, or 8 from the “Data bits” drop-down list for the serial port. The default Data bits of the serial port is 8 bits.

Stop bits: Click “Stop bits” drop-down menu to select Stop bits 1 or 2 from the “Stop bits” drop-down list for the serial port. The default Stop bits of the serial port is 1 bit.

Parity: Click “Parity” drop-down menu to select Parity None,

Industrial Serial Device Server

Even, Odd, Mark, or Space from the “Parity” drop-down list for the serial port. The default Parity of the serial port is None.

Flow control: Click “Flow control” drop-down menu to select Flow control None, Hardware, or Software from the “Flow control” drop-down list for the serial port. The default Flow control of the serial port is None.

Mode: Click “Mode” drop-down menu to select Mode RS232, RS422, or RS485 from the “Mode” drop-down list for the serial port. The default Mode of the serial port is RS232.

- Step 3: Protocol timeout setting

Support protocol timeout auto-detect: Check this option to support protocol timeout auto-detect. The Serial Device Server will automatically test the TCP connection to remote host. If the TCP connection is idle, the TCP connection will be closed and the port will be freed for other hosts.

Protocol timeout: Click in “Protocol timeout” text box and type a period of Protocol timeout assigned to the serial port on the Serial Device Server. The connection will be closed and the port will be freed for connection with other hosts when serial port stops data transmission for a defined period of time (Protocol timeout). The default Protocol timeout is 0ms.

- Step 4: Data Packing

Delimiter1, 2: Check this option to enable Delimiter1, 2. Click in “Delimiter1, 2” text box and Delimiter1, 2 assigned to the serial port on the Serial Device Server. The data will be transmitted if the Delimiter1 is received or Delimiter1 and Delimiter are received.

Force transmit: Click in “Force transmit” text box and specify Force transmit to the serial port on the Serial Device Server. The data will be transmitted when the Force transmit is reached. The default Force transmit of the serial port is 0 to disable Force transmit.

- Step 5: Client Network settings

Remote IP 1 ~ 8: Click in “Remote IP 1 ~ 8” text boxes to

Industrial Serial Device Server

specify IP addresses and Port numbers of remote host computers.

Connect timeout: Click in “Connect timeout” text box and type a period of Connect timeout assigned to the serial port on the Serial Device Server. The connection will be closed and the port will be freed for connection with other hosts when serial port stops data transmission for a defined period of time (Connect timeout). The default Connect timeout is 3 seconds.

Reconnect interval: Click in “Reconnect interval” text box and type a period of Reconnect interval assigned to the serial port on the Serial Device Server. The connection will be reestablished with other hosts for a defined period of time (Reconnect interval). The default Reconnect interval is 3 seconds.

RFC2217: RFC2217 is used to establish a transparent connection between a host computer and a serial device by mapping the serial port on the Serial Device Server to a local COM port on the host computer. Check this option to enable RFC2217 for TCP Client Setting.

Restart Port: Check this option to restart the serial port on the Serial Device Server when you click the “OK” button to finish TCP Client Setting.

Apply the above settings to all serial ports: Click this button to apply the above settings to all serial ports.

4. UDP

- Step 1: Xport mode

Choose “UDP” from the “Step 1: Xport mode”.

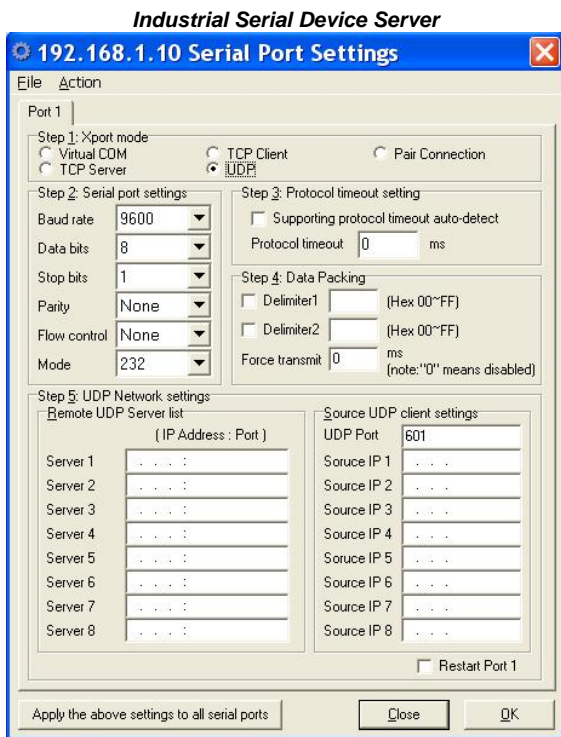

Fig 79. UDP

- Step 2: Serial port settings

Baud rate: Click “Baud rate” drop-down menu to select Baud rate 50 ~ 460800bps from the “Baud rate” drop-down list for the serial port. The default Baud rate of the serial port is 9600bps.

Data bits: Click “Data bits” drop-down menu to select Data bits 5, 6, 7, or 8 from the “Data bits” drop-down list for the serial port. The default Data bits of the serial port is 8 bits.

Stop bits: Click “Stop bits” drop-down menu to select Stop bits 1 or 2 from the “Stop bits” drop-down list for the serial port. The default Stop bits of the serial port is 1 bit.

Parity: Click “Parity” drop-down menu to select Parity None,

Industrial Serial Device Server

Even, Odd, Mark, or Space from the “Parity” drop-down list for the serial port. The default Parity of the serial port is None.

Flow control: Click “Flow control” drop-down menu to select Flow control None, Hardware, or Software from the “Flow control” drop-down list for the serial port. The default Flow control of the serial port is None.

Mode: Click “Mode” drop-down menu to select Mode RS232, RS422, or RS485 from the “Mode” drop-down list for the serial port. The default Mode of the serial port is RS232.

- Step 3: Protocol timeout setting

Support protocol timeout auto-detect: Check this option to support protocol timeout auto-detect. The Serial Device Server will automatically test the TCP connection to remote host. If the TCP connection is idle, the TCP connection will be closed and the port will be freed for other hosts.

Protocol timeout: Click in “Protocol timeout” text box and type a period of Protocol timeout assigned to the serial port on the Serial Device Server. The connection will be closed and the port will be freed for connection with other hosts when serial port stops data transmission for a defined period of time (Protocol timeout). The default Protocol timeout is 0ms.

- Step 4: Data Packing

Delimiter1, 2: Check this option to enable Delimiter1, 2. Click in “Delimiter1, 2” text box and Delimiter1, 2 assigned to the serial port on the Serial Device Server. The data will be transmitted if the Delimiter1 is received or Delimiter1 and Delimiter are received.

Force transmit: Click in “Force transmit” text box and specify Force transmit to the serial port on the Serial Device Server. The data will be transmitted when the Force transmit is reached. The default Force transmit of the serial port is 0 to disable Force transmit.

- Step 5: UDP Network settings

Server 1 ~ 8: Click in “Server 1 ~ 8” text boxes to specify IP

Industrial Serial Device Server

addresses and Port numbers of remote UDP Servers.

UDP Port: Click in “UDP Port” text box and type a UDP Port number assigned to the Source UDP Clients. The default UDP Port number is 601.

Source IP 1 ~ 8: Click in “Source IP 1 ~ 8” text box to specify IP addresses of Source UDP Clients.

Restart Port: Check this option to restart the serial port on the Serial Device Server when you click the “OK” button to finish UDP Setting.

Apply the above settings to all serial ports: Click this button to apply the above settings to all serial ports.

5. Pair Connection

- Step 1: Xport mode

Choose “Pair Connection” from the “Step 1: Xport mode”.

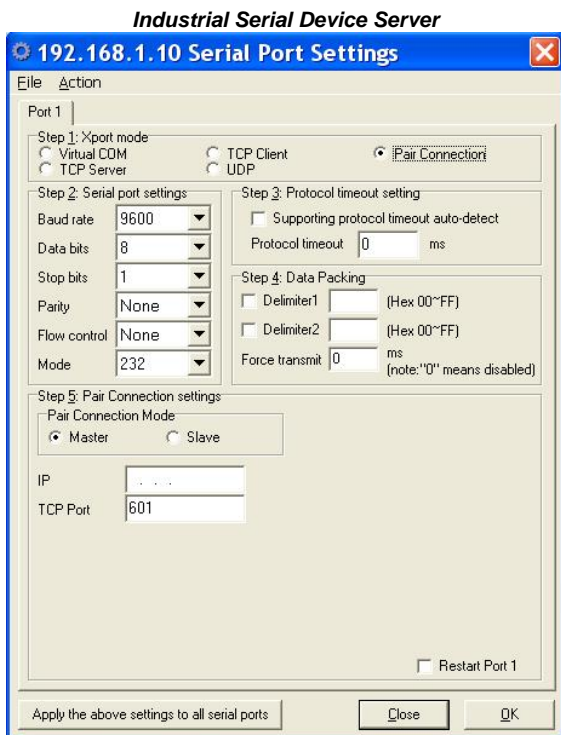

Fig 80. Pair Connection

- Step 2: Serial port settings

Baud rate: Click “Baud rate” drop-down menu to select Baud rate 50 ~ 460800bps from the “Baud rate” drop-down list for the serial port. The default Baud rate of the serial port is 9600bps.

Data bits: Click “Data bits” drop-down menu to select Data bits 5, 6, 7, or 8 from the “Data bits” drop-down list for the serial port. The default Data bits of the serial port is 8 bits.

Stop bits: Click “Stop bits” drop-down menu to select Stop bits 1 or 2 from the “Stop bits” drop-down list for the serial port. The default Stop bits of the serial port is 1 bit.

Parity: Click “Parity” drop-down menu to select Parity None,

Industrial Serial Device Server

Even, Odd, Mark, or Space from the “Parity” drop-down list for the serial port. The default Parity of the serial port is None.

Flow control: Click “Flow control” drop-down menu to select Flow control None, Hardware, or Software from the “Flow control” drop-down list for the serial port. The default Flow control of the serial port is None.

Mode: Click “Mode” drop-down menu to select Mode RS232, RS422, or RS485 from the “Mode” drop-down list for the serial port. The default Mode of the serial port is RS232.

- Step 3: Protocol timeout setting

Support protocol timeout auto-detect: Check this option to support protocol timeout auto-detect. The Serial Device Server will automatically test the TCP connection to remote host. If the TCP connection is idle, the TCP connection will be closed and the port will be freed for other hosts.

Protocol timeout: Click in “Protocol timeout” text box and type a period of Protocol timeout assigned to the serial port on the Serial Device Server. The connection will be closed and the port will be freed for connection with other hosts when serial port stops data transmission for a defined period of time (Protocol timeout). The default Protocol timeout is 0ms.

- Step 4: Data Packing

Delimiter1, 2: Check this option to enable Delimiter1, 2. Click in “Delimiter1, 2” text box and Delimiter1, 2 assigned to the serial port on the Serial Device Server. The data will be transmitted if the Delimiter1 is received or Delimiter1 and Delimiter are received.

Force transmit: Click in “Force transmit” text box and specify Force transmit to the serial port on the Serial Device Server. The data will be transmitted when the Force transmit is reached. The default Force transmit of the serial port is 0 to disable Force transmit.

- Step 5: Pair Connection settings

Pair Connection Mode: Choose Master or Slave from the

Pair Connection Mode.

IP: Click in “IP” text box and specify the IP address of the Slave Serial Device Server of Pair Connection.

TCP Port: Click in “TCP Port” text box and type a TCP Port number assigned to the serial port on the Serial Device Server. The default TCP Port number is 601.

Restart Port: Check this option to restart the serial port on the Serial Device Server when you click the “OK” button to finish Pair Connection Setting.

Apply the above settings to all serial ports: Click this button to apply the above settings to all serial ports.

8.6.2. Basic Network Settings

Click “Basic Network Settings” from “Setting” to configure the Serial Device Server.

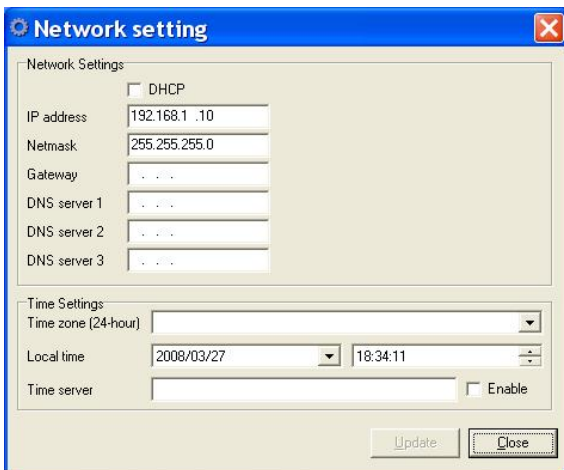

Fig 81. Basic Network Settings

Network Settings

1. DHCP: Click this option to enable “DHCP” so that DHCP

Industrial Serial Device Server

server automatically supplies an IP address, gateway address, and subnet mask to Serial Device Server.

2. IP address: Click in “IP address” text box and type a new address to change the IP address.
3. Netmask: Click in “Netmask” text box and type a new address to change the Netmask.
4. Gateway: Click in “Gateway” text box and type a new address to change the Gateway.
5. DNS server 1, 2, 3: Click in “DNS server 1”, “DNS server 2”, or “DNS server 3” text box and fill in DNS information.

Time Settings

1. Time zone (24-hour): Click “Time zone” drop-down menu to select a different time zone from the “Time zone” drop-down list.
2. Local time: Click “Local time” drop-down menu to change date for the Serial Device Server. And adjust time for the Serial Device Server.
3. Time server: Click in “Time server” text box to enter Time server address for the Serial Device Server. And check “Enable” to enable this setting.

8.6.3. System Management

Click “System Management” from “Setting” to configure the Serial Device Server.

Fig 82. System Management

Server Name Settings

Server Name: Click in “Server name” text box and specify Server name to the Serial Device Server.

Change Password

1. Old password: Click in “Old password” text box and enter the Old password of the Serial Device Server.
2. New password: Click in “New password” text box and enter the New password for the Serial Device Server.
3. Confirm password: Click in “Confirm password” text box and enter the New password again for the Serial Device Server.

SNMP Trap

IP of remote SNMP trap receiver: Click in “IP of remote SNMP trap receiver” text box and enter IP address of the remote SNMP trap receiver.

E-mail Alert

1. SMTP Setting:

Industrial Serial Device Server

- SMTP Host: SMTP (Simple Mail Transfer Protocol). Click in “SMTP Host” text box and enter IP address of the SMTP Host.
 - SMTP Port: Click in “SMTP Port” text box and enter the SMTP Port number. The default SMTP Port number is 25.
2. From E-Mail address
 - From E-mail address: Click in “From E-mail address” text box and specify the E-mail address to receive the E-mail from.
 3. E-mail addresses to report
 - E-mail address1 ~ 4: Click in “E-mail address1 ~ 4” text box and specify the E-mail addresses to receive the E-mail. Check this option to enable E-mail address1 ~ 4.

Firmware Update

Select file: Click the “Search File” button to search the firmware file to be updated to the Serial Device Server.

8.6.4. Utility Setting

Click “Utility Setting” from “Setting” to configure the Serial Device Server.

Environment

1. Auto-detect Device on start: Check this option to enable the Serial Device Server to automatically detect whether the connected serial device is started up.
2. Auto-polling: Click in “Auto-polling” text box and type a period of Auto-polling time assigned to Serial Device Server. The default Auto-polling is per 2 seconds.

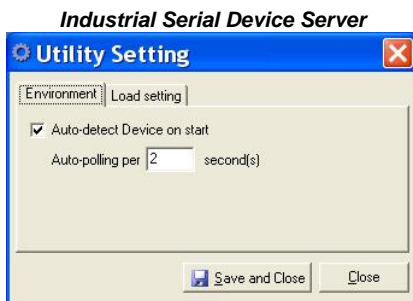

Fig 83. Environment

Load setting

1. Replace network setting: Check this option to replace the network setting of the Serial Device Server when you load setting to the Serial Device Server.
2. Replace account and password: Check this option to replace the account and password of the Serial Device Server when you load setting to the Serial Device Server.
3. Replace host name: Check this option to replace the host name of the Serial Device Server when you load setting to the Serial Device Server.
4. Show this page when load file: Check this option to show this Utility Setting page when user loads setting to the Serial Device Server.



Fig 84. Load setting

8.7. Monitoring

Click "Monitoring" from menu bar to show as Fig 85.

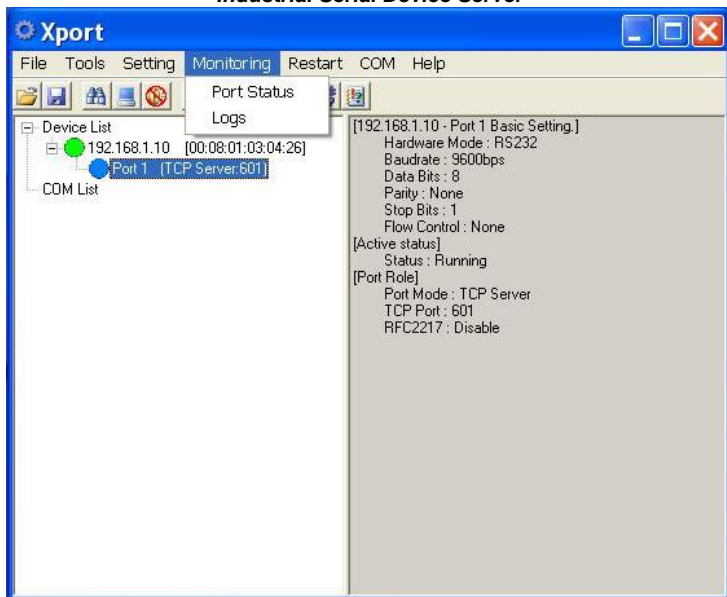

Fig 85. Monitoring

8.7.1. Port Status

Click “Port Status” from “Monitoring” to view the Port Status of the Serial Device Server.

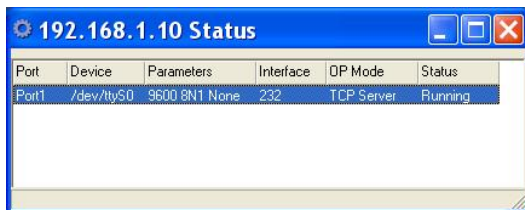

Fig 86. Port Status

8.7.2. Logs

System

User can view the System Log of the Serial Device Server.

Industrial Serial Device Server

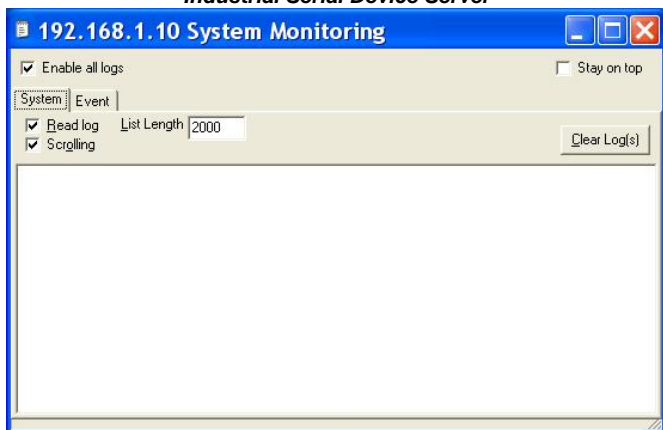

Fig 87. System

Event

User can view the Event Log of the Serial Device Server.

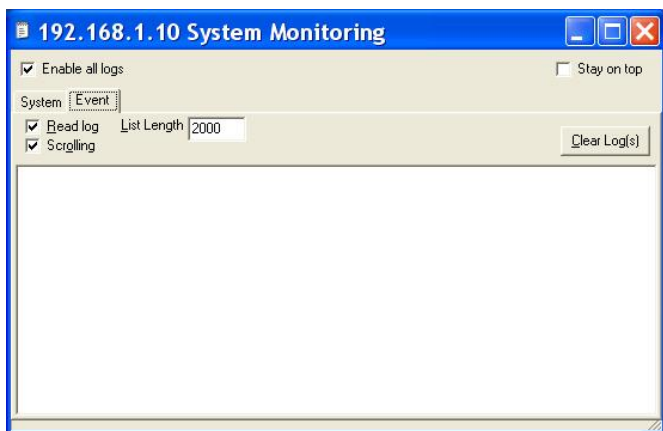

Fig 88. Event

8.8. Restart

Click "Restart" from menu bar to show as Fig 89.

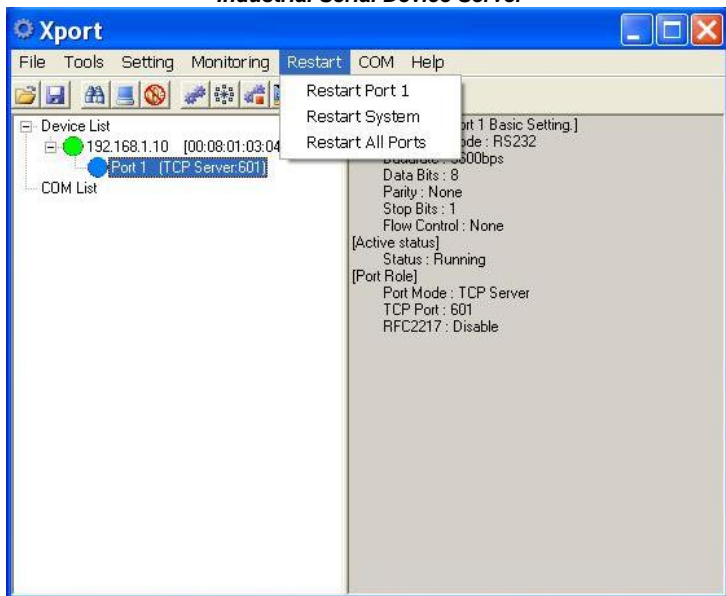

Fig 89. Monitoring

8.8.1. Restart Port

Click “Restart Port” from “Restart” to select the serial port on the Serial Device Server to be restarted.

8.8.2. Restart System

Click “Restart System” from “Restart” to restart the Serial Device Server.



Fig 90. Restart System

8.8.3. Restart All Ports

Click “Restart All Ports” from “Restart” to select all serial ports on the Serial Device Server to be restarted.

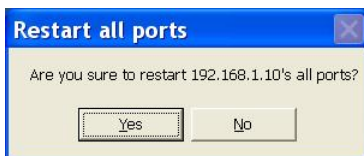

Fig 91. Restart All Ports

8.9. COM

Click “COM” from menu bar to show as Fig 92.

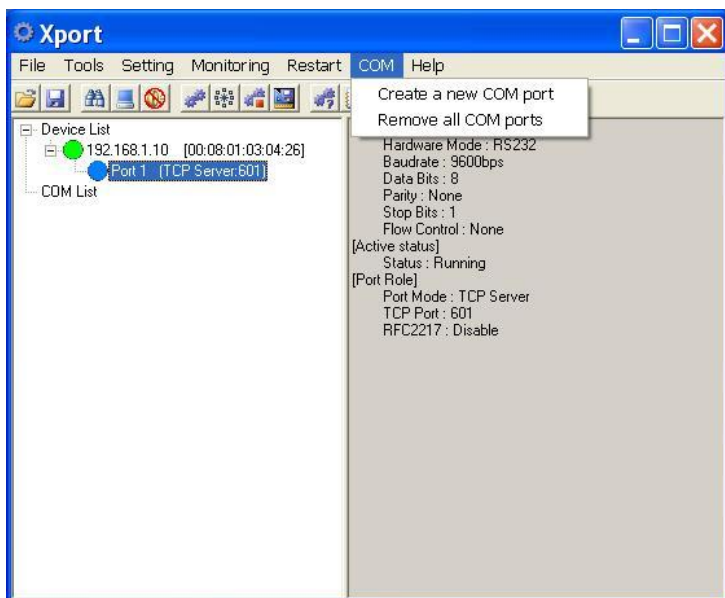

Fig 92. COM

8.9.1. Create a new COM port

Click “Create a new COM port” from “COM” to map a serial port to a COM port on a PC. The serial port on the Serial Device Server has to be set to Virtual Com mode when mapping COM port with Xport utility.

Network setting

1. Remote IP address: Input the IP address of the remote Serial Device Server.
2. TCP port: Choose TCP port number assigned to the COM port. The default TCP port number is 601.
3. Active auto-reconnect: Check this option to support Active auto-reconnect. The Xport utility will automatically attempt to reconnect COM port to the serial port on the Serial Device Server.
4. Reconnect interval: The Xport utility will automatically attempt to reconnect COM port to the serial port on the Serial Device Server in defined time interval (Reconnect interval). The default Reconnect interval is 1000ms.
5. Cache data when connection was broken: Check this option to ensure that data is buffered if the connection is broken.

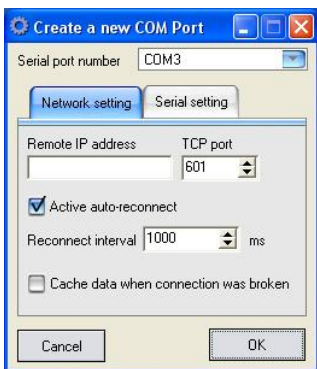

Fig 93. Network setting

Serial setting

1. Serial port protocol: Choose Raw protocol or RFC2217 protocol.

Industrial Serial Device Server

2. Serial port preset signals: There are CTS, DSR, DCD, and RING serial port preset signals that can be chosen.
3. Enable bitrate emulation: Check this option to limit data transmission speed to that was specified to serial port. Transmission speed depends on bandwidth of the serial connection if bitrate emulation is disabled.

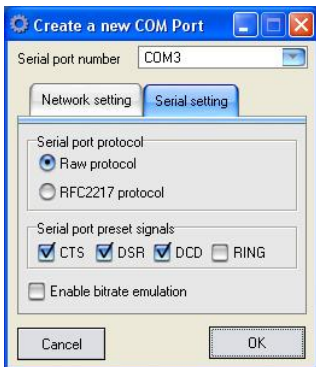

Fig 94. Serial setting

8.9.2. Remove all COM ports

Click "Remove all COM ports" to remove all the COM ports and remove all the mapping from the serial ports to COM ports on a PC.

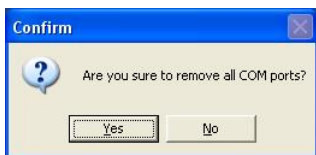

Fig 95. Remove all COM ports

8.10. Help

Click "Help" from menu bar to show as Fig 96. Click "About utility" from "Help" to show the version of Xport utility as Fig 97.

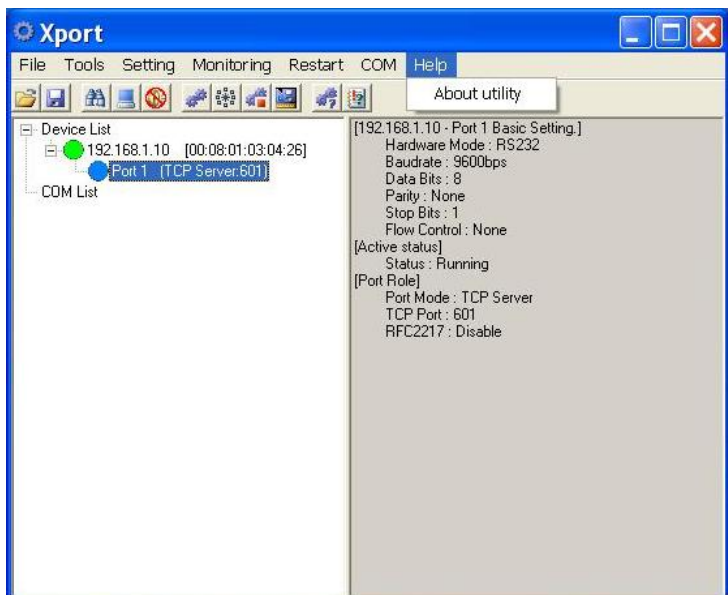

Fig 96. Help



Fig 97. About utility

9. Specifications

9.1. Hardware Specifications

Applicable Standards	IEEE 802.3 10Base-T IEEE 802.3u 100Base-TX/FX
Switching Method	Store-and-Forward
Forwarding Rate	
10Base-T	10 / 20Mbps half / full-duplex
100Base-TX	100 / 200Mbps half / full-duplex
100Base-FX	200Mbps full-duplex
Performance	14,880pps for 10Mbps 148,810pps for 100Mbps
Cable	
10Base-T	2-pair UTP/STP Cat. 3, 4, 5 Up to 100m (328ft)
100Base-TX	2-pair UTP/STP Cat. 5 Up to 100m (328ft)
100Base-FX	50 or 62.5/125µm multi-mode fiber (1300nm) up to 2km 9 or 10/125µm single-mode fiber (1300nm) up to 75km
Serial Port	
Interface	RS-232/422/485
Connector	DB9 (RS-232/422/485), Terminal Block (RS-422/485)
Line Protection	15KV ESD
Isolation	2KV
Serial Communication Parameters	
Parity	None, Even, Odd, Mark, Space
Data Bits	5, 6, 7, 8
Stop Bit	1, 2
Flow Control	None, Hardware, Software
Speed	50bps to 460.8Kbps
LED Indicators	Per unit – Power status (Power 1, 2), Status Ethernet port – LAN (Link/Activity) Serial port – Port TX/RX (Link/Activity)
Dimensions	70mm (W) x 110mm (D) x 30mm (H) (2.76" (W) x 4.33" (D) x 1.18" (H))
Net Weight	0.25Kg (0.55lb.)
Power Input	DC Jack: 12VDC Terminal Block: 12~32VDC
Power Consumption	2.88W Max. 0.24A @ 12VDC, 0.12A @ 24VDC
Operating Temperature	-10°C to 60°C (14°F to 140°F)
Storage Temperature	-20°C to 85°C (-4°F to 185°F)
Humidity	5%-95% non-condensing
Emission Compliance	CE Mark Class A FCC Part 15 Class A VCCI Class A

9.2. Pin Assignments

Pin assignments for serial port

- DB-9:

Pin#	RS-232	RS-422 4-wire RS-485	2-wire RS-485
1	DCD	TxD+	
2	RxD	RxD-	D-
3	TxD	RxD+	D+
4	DTR		
5	Signal GND	Signal GND	Signal GND
6	DSR		
7	RTS	TxD-	
8	CTS		
9	RI		

- Terminal Block:

Pin#	RS-422 4-wire RS-485	2-wire RS-485
1	RxD-	D-
2	RxD+	D+
3	Signal GND	Signal GND
4	TxD-	
5	TxD+	