

Installation Instructions

SP100, SP200, SP300 Series

AC Panel Surge Protective Devices

These UL 1449 certified Type 2 SPDs are compact, high performance surge protection solutions for all typical commercial and industrial AC power environments with critical operations. They are available in 100~300kA per phase surge ratings.

Damaging overvoltage transients can result from:

- Direct and indirect lightning strikes
- Power company load switching
- Motor/Generator switching

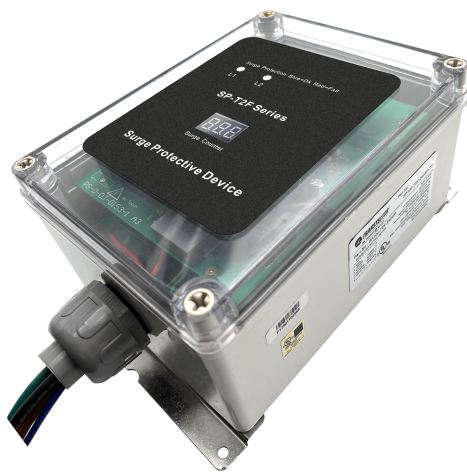

PRODUCT SPECIFICATIONS

8/20 μ s Surge capacity per phase	100 kA, SP100 series
	200 kA, SP200 series
	300 kA, SP300 series
Certifications	UL1449 4th, CSA C22.2 Type 2 SPD UL 1283 EMI/RFI filter
Connection type	Parallel Connected
Ports	1
Nominal discharge current (In)	20 kA
SCCR rating	200kArms
UL 1283 EMI/RFI filtering	Sine wave tracking
Lightning counter current threshold	$\geq 200A$ (with Reset button)
Power Status Indication	Normal=Blue LED ON
Working Status Indication	Normal= Blue LED ON; Fail= Blue LED turn to Red
Audible alarm	Buzzer inside, beep while SPD fail
AC power connections	#10 AWG, 762mm (30") length A(L1)=black; B(L2)=red; C(L3)=blue; N=white; PE=green
Remote alarm contacts	#16 AWG, 762mm (30") length C=red; NC=blue; NO=brown
Operating environments	Temperature $-40^{\circ}C \sim +75^{\circ}C$, Humidity relative 5~95% (25 $^{\circ}C$) , Altitude $\leq 3km$
Storage environments	Temperature $0^{\circ}C \sim +45^{\circ}C$, Humidity relative $\leq 75\%$ (25 $^{\circ}C$)
Dimensions, W x D x H	200 x 150 x 100 mm
Threaded NPT	3/4"NPT
Enclosure	Plastic

The SPD Types Per ANSI/UL 1449 4th:

Type 1 – Permanently connected SPDs intended for installation between the secondary of the service transformer and the line side of the service equipment overcurrent device, as well as the load side, including watt-hour meter socket enclosures and Molded Case SPDs intended to be installed without an external overcurrent protective device. Type 1 SPDs for use in PV systems can be connected between the PV array and the main service disconnect.

Type 2 – Permanently connected SPDs intended for installation on the load side of the service equipment overcurrent device; including SPDs located at the branch panel and Molded Case SPDs.

Type 3 – Point of utilization SPDs, installed at a minimum conductor length of 10 meters (30 feet) from the electrical service panel to the point of utilization, for example cord connected, direct plug-in, receptacle type and SPDs installed at the utilization equipment being protected. The distance (10 meters) is exclusive of conductors provided with or used to attach SPDs.

WARNING!



Only qualified personnel should install or service this system. Electrical safety precautions must be followed when installing or servicing this equipment. To prevent risk of electrical shock, turn off and lock out all power sources to the unit before making electrical connections or servicing.

For proper and safe operation, neutral and ground **MUST** be reliably connected. Failure to operate this unit from a solidly grounded power source of the proper configuration will reduce or impede operation and may result in unit failure.

AVERTISSEMENT !



Seul du personnel qualifié doit installer ou réparer ce système. Des précautions de sécurité électrique doivent être suivies lors de l'installation ou de l'entretien de cet équipement.

Pour éviter tout risque de choc électrique, éteignez et verrouillez toutes les sources d'alimentation de l'unité avant d'effectuer les connexions électriques ou l'entretien. Pour un fonctionnement correct et sûr, le neutre et la terre DOIVENT être connectés de manière fiable. Le fait de ne pas faire fonctionner cet appareil à partir d'une source d'alimentation solidement mise à la terre de la configuration appropriée réduira ou gênera le fonctionnement, et peut entraîner une panne de l'appareil.

CONFIGURATION AND OPERATION

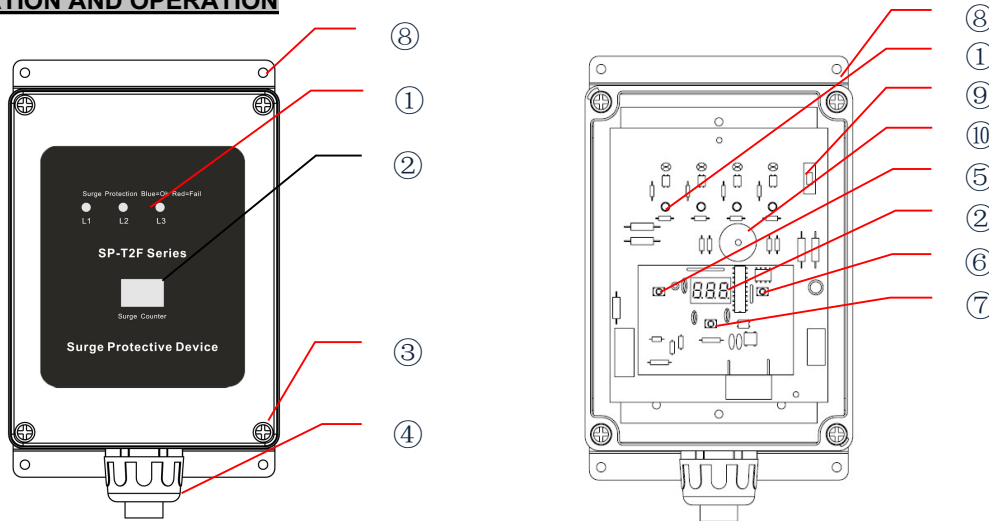

Fig 1: Diagram of SP series features

- ① **Working Status Indication**, the line status LEDs provide visual indication of SPD health status. While the SPD is connected to the electrical system supply voltage, the line status indicators will be illuminated blue. There is one LED indicator per each protected phase on SP Models. When the Line loses of protection, the LED will be illuminated red.
- ② **Lightning counter**, the lightning counter will detect the lightning strike /surge, and the screen will show the cumulative times of surge event, which can help user to investigate.
- ③ **Cover plate mounting screw**, to lock the cover.
- ④ **Threaded NPT**, 3/4" NPT, #10 AWG for power connection (L1=black; L2=red; L3=blue; N=white; PE=green); #16 AWG for remote signal connection (C=red; NC=blue; NO=brown).
- ⑤ **Failure pre-test button**, while press the button for 2 seconds, it will simulate that the protection mode of Line 1 failure, then the Working status indication of Line 1 will turn red, and remote signal (optional, if using) will change-over.
- ⑥ **Lightning Counting Circuit Reset Button**, press the button to reset the circuit /chip of surge counting.
- ⑦ **Lightning Counter reset button**, press this button to simply zero out the counter if needed.
- ⑧ **Fixed support**, used to mount the SP series models on the wall by bolt.
- ⑨ **Buzzer turn off/on toggle switch**, used to turn off/on buzzer.
- ⑩ **Buzzer**, buzzing while SPD fail.

INSTALLATION

Mounting – Mount unit as close as possible to the service panel, using mounting hardware. For best performance, unit should be positioned so that the length of the wiring to the surge protective device (SPD) unit is minimized.

Installation Instructions

Wire Sizing/Routing - #10 AWG and 762mm (30”) length wiring is provided with unit. The length of wiring to the SP series must be kept at a minimum for the best performance, excess wires need to be cut and not coiled up. Wire lengths should be short, straight runs between the SP series and power source. To reduce the wiring impedance to surge currents, the phase, neutral (if required), and ground conductors are recommended to be twisted together and routed in the same race way (conduit). Avoid any sharp bends in the conductors. All wiring must comply with the National Electrical Code (NEC) and applicable local codes.

Conduit Connection - Feed all wires into the panel through the knockout selected and secure.

Wiring Connections – Before making connections to the unit, verify that the unit model number and nameplate voltage rating are appropriate for connection to the intended power source. Please check it according to table 1 below.

WARNING !



Select the proper **L-COM** SP series SPD unit according to your system voltage, configuration, and the anticipated surge environment.

Prior to install the SPD, ensure that your facility electric supply system is properly installed and connected in according with all applicable national and local codes and safety procedure.

Never Hi-Pot Test Any SPD. (Will prematurely fail SPD)

AVERTISSEMENT !



Sélectionnez l'unité SPD **L-COM** SP appropriée en fonction de la tension de votre système, de la configuration et de l'environnement de surtension prévu.

Avant d'installer le SPD, assurez-vous que le système d'alimentation électrique de votre installation est correctement installé et connecté conformément à tous les codes nationaux et locaux applicables et à la procédure de sécurité.

Table 1 - AC power service diagrams & SPD wire connections

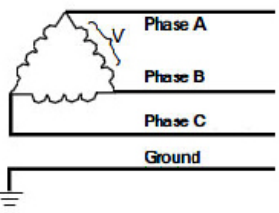
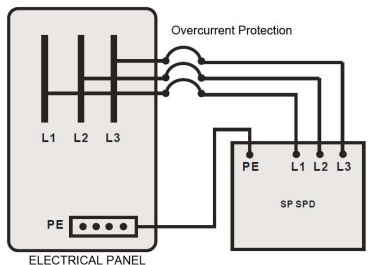
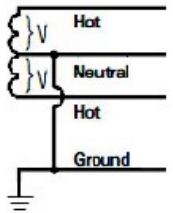
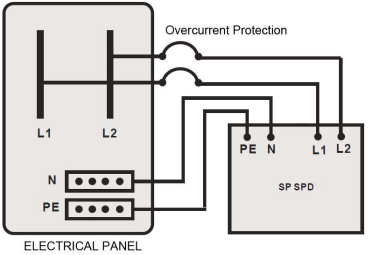
Part No.	Nominal Voltage (50/60Hz)	MCOV	Service Diagrams	Wire Connections
SP100-T2F-2403D-LC SP100-T2F-2403D-LC SP100-T2F-2403D-LC	240 V	320 V	Three phase Delta, 3W+G 	
SP100-T2F-4803D-LC SP100-T2F-4803D-LC SP100-T2F-4803D-LC	480 V	550 V		
SP100-T2F-240SP-LC SP100-T2F-240SP-LC SP100-T2F-240SP-LC	120/240 V	150 V	Split phase 	

Installation Instructions

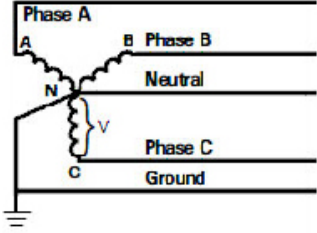
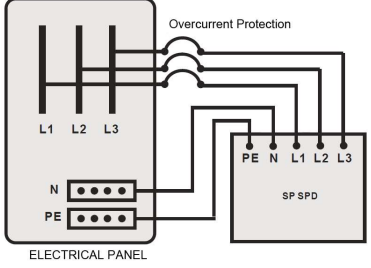
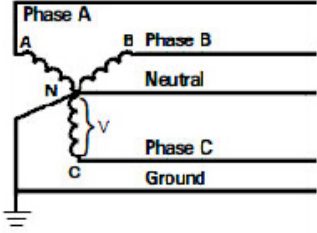
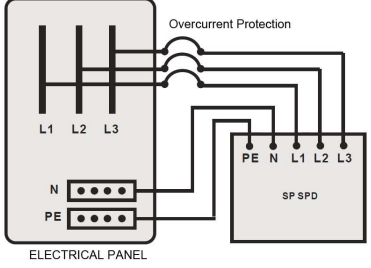
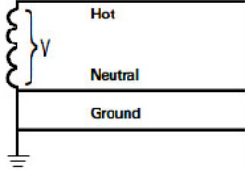
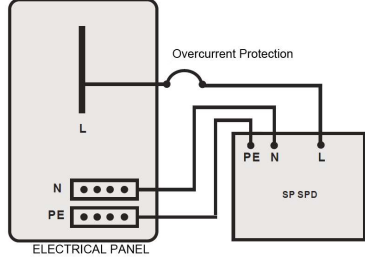
SP100-T2F-1203Y-LC SP200-T2F-1203Y-LC SP300-T2F-1203Y-LC	120/208 V	150 V	Three phase WYE, 4W+G 	
SP100-T2F-2773Y-LC SP200-T2F-2773Y-LC SP300-T2F-2773Y-LC	277/480 V	320 V		
SP100-T2F-1201P-LC SP100-T2F-1201P-LC SP100-T2F-1201P-LC	120 V	150 V	Single phase, 2W+G 	

1. Connect Black /Red/Blue Phase Wires to corresponding phase on the service panel.
2. Connect the White wire of the SPD (if provided) to the neutral of the supply and the Green wire of the SPD to source ground.
3. If using remote sensing, connect the Red (COM), Blue (NC), and Brown (NO) wires (#16 AWG). If not using relay contacts for remote sensing, cut and dress wires.

Remote alarm contact type	Floating changeover contact
Remote Alarm Contact	AC: 250V/5A
Capability Un/In	DC: 30V/5A
Com-No Breakover	SPD Fault, replace unit
Com-Nc Breakover	SPD is OK

Suggested Circuit Breaker

Over current Protection: 60A Recommended, 30A Minimum.

In addition to safety, the dedicated breaker performs the following functions:

- Allows power to the protector's to be removed without interrupting power to other loads.
- Should a component fail inside the protector, only the protector's breaker will trip, and power to other loads is not disturbed.

Applying Power – Apply power to the SPD and assure status indications are normal. Under normal conditions, all Blue OK LEDs are illuminated. If normal status indication does not exist, red LEDs will be illuminated.

To be noticed that indication circuit is powered by L1 (or L, if single phase), if L1 (or L) is not connected to power line, the indication circuit will not work,

FAULT INDICATION

When the phase Line loses of protection, the LED on the front panel will be illuminated red. At the same time, the COM and NO remote signal contacts will be closing.

The buzzer will sound upon SPD failure (one or more phase loss of protection)

Installation Instructions

PRODUCT RATINGS AND LIMITATIONS

Voltage Protection Rating – To obtain the voltage protection ratings (VPRs), in accordance with the Standard for Safety, Surge Protective Devices (SPDs), Standard 1449 Fourth Edition, released 2014, indicated on this product, the wire supplied must be utilized to connect the SPD to your facilities power grid. Connections made with unapproved conductors may result in different VPRs.

Circuit Ampacity Limitations – This device has been investigated to withstand, without exposing live circuits or components on power sources, a voltage of two times (2x) the device ratings, and fault currents of up to 200,000 AIC, as described in the Standard for Safety, Surge Protective Devices (SPDs), Standard 1449, Fourth Edition, released 2014.

TROUBLESHOOTING

If any of the diagnostic indicators indicates a problem, check all connections and voltages to the unit. If all connections are made and reliable, and proper voltages are supplied to the unit, please contact www.l-com.com.

NOTE

This instruction is not comprehensive. It's assumed the user will follow established safety precautions for working in an electrical environment. For more information on safety precautions and procedures, please find from related organizations as below.

- Underwriters Laboratories(UL)
- American National Standards Association(ANSI)
- Institute of Electrical and Electronics Engineers (IEEE).
- National Fire Protection Association (NFPA)
- National Electrical Manufacturers Association (NEMA)

INSTALLATION DIMENSION

Note: units are in mm

