

LINEAR AC SENSOR & OVER-CURRENT PROTECTOR

User Guide for SRCN-C267-1



Product Description >>

This module is used to measure and monitor current consumption by utilizing electromagnetic current transformer technology. A voltage output is produced in direct proportion to the measured current. If the current exceeds a preset value, the relay on the module is activated. Uses include building automation and facility management systems, where acquiring information on energy usage can lead to increased efficiency. They can also detect equipment issues and help prevent damage by detecting over-current and/or short-circuit conditions.

Features >>

- Split-core coil
- Measuring range 0 – 100 A
- CT technology
- High accuracy, $\pm 1\%$ of full scale range
- Analog and relay output with adjustable linear output (0 – 5 V)
- 35 mm DIN rail or board mount

Applications >>

- Building and facilities management
- HVAC
- Electric fans
- Electric pumps
- Devices requiring over-current & short-circuit protection

Thank you for choosing L-com product. To ensure safe, accurate performance and product longevity, please take a moment to familiarize yourself with this manual before powering the device. Please keep it handy for future reference. In case of any questions regarding the installation or use of product, please call us at 800.341.5266.

Reach out to us at customerservice@l-com.com and visit our website at www.l-com.com

Technical Parameters >>

Working voltage		24 VDC \pm 0.5 VDC
Working current	Before protection	\leq 25 mA
	After protection	\leq 90 mA
Working temperature		0 – 70 °C
Working humidity		10 – 90% (No condensation)
Detection range		0 – 100 A
Output mode		Relay output
		Analog output
Alarm mode LED judgement	Red LED ON	Overcurrent
	Red LED OFF	Normal
Installation mode	Pedestal	Mounting on 35mm DIN rail
	Module	Mounting with screws

Output Correlation Table >>

The corresponding relation table is of the output voltage and the detection current (0 – 5 V corresponds to 0 – 100 A).

Vout	A	Vout	A	Vout	A	Vout	A	Vout	A
1	20	2	40	3	60	4	80	5	100

Electrical Diagram >>

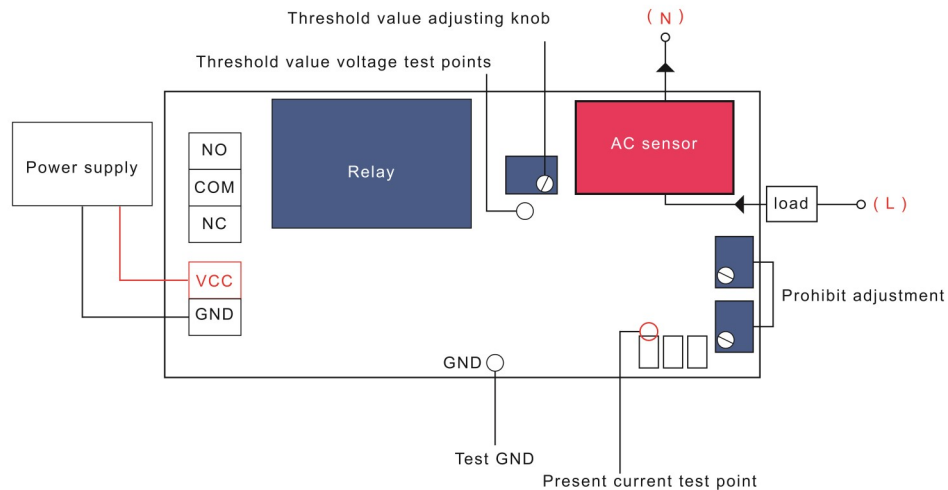

Mounting Diagram >>

35mm DIN rail mounting: Mount the sensor module onto the DIN rail (dark black) as shown in the figure.

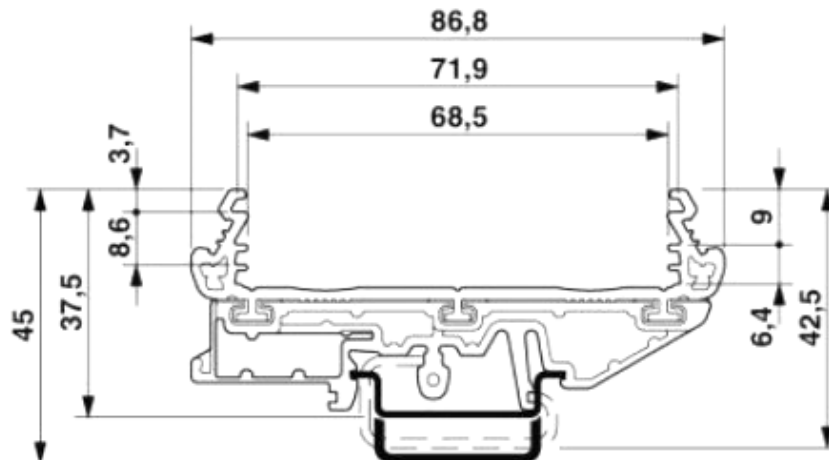

Board Mount >>

Mount the PCB to the enclosure with screws. Mounting hole diameter is 3mm.

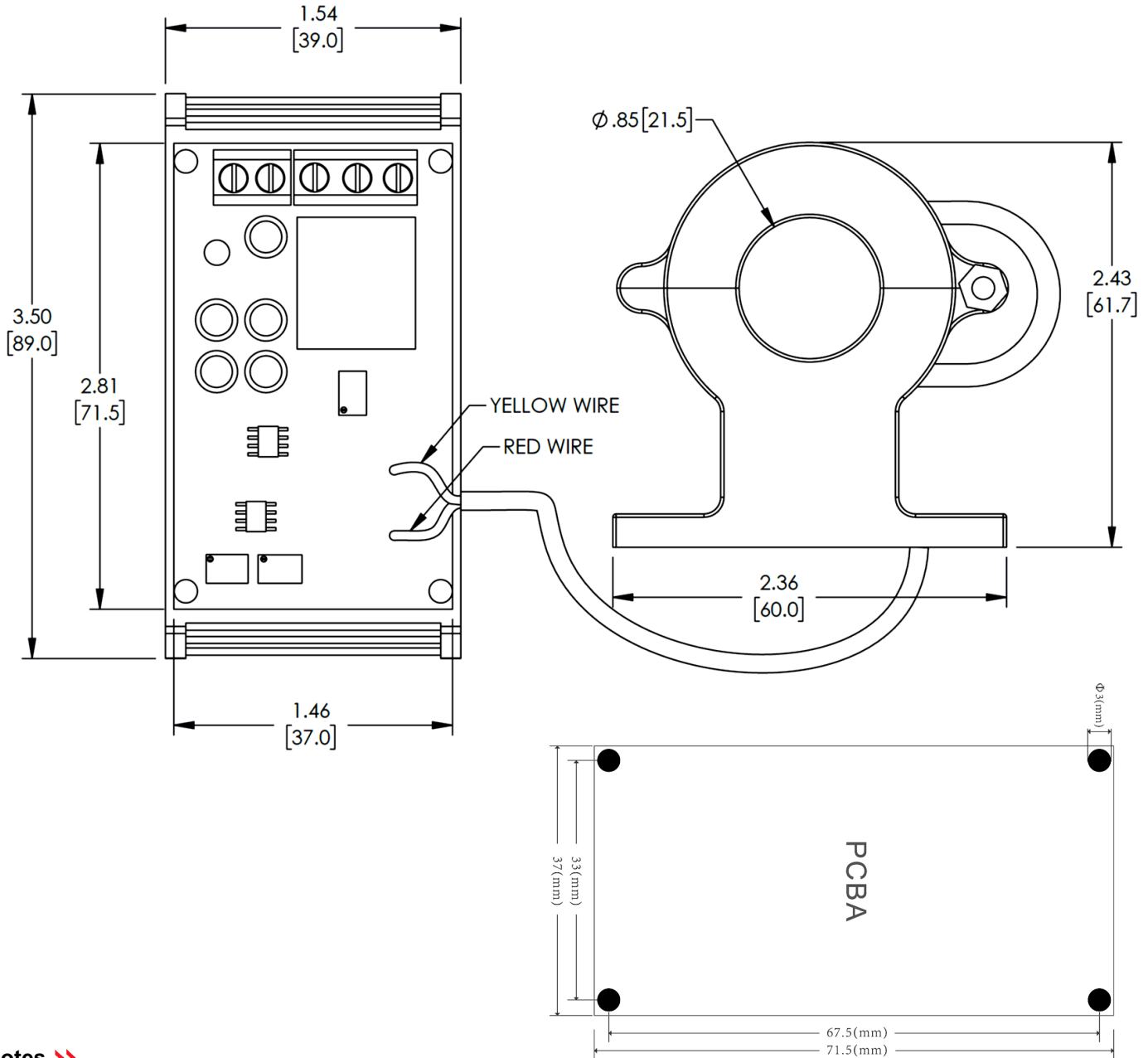

Notes >>

1. The module can only be powered by 24 VDC. The module has reverse voltage protection function and power indicator lights (N: green light, L: yellow light) to help with power connection.
2. Set the current threshold to 2 A. According to corresponding relationship between current and voltage, the corresponding voltage threshold value is 2 V. Set it at 1.97 V because of circuit characteristics.
3. The modules are tested with pure resistance loads when they leave the factory. If user uses inductive or capacitive loads, the detected current will be offset. See correction method to set this.
4. For users who have frequent current changes and need to use the relay terminal on the module to control, it is recommended to connect an AC contactor to the relay output terminal. It will prevent the relay from being frequently activated, which can cause damage.

Correction Method >>

The VR2 and VR3 potentiometers are factory set, the user cannot adjust them. Only when the module has a large error, recalibrate the two potentiometers. Following is the correction method:

1. When the module is powered ON, in the case of no current detection, measure the ground voltage at point B of the module, and adjust the voltage at this point to 0 V through the VR2 potentiometer.
2. Then add a known current such as 2 A, measure the ground voltage of point B, and adjust the voltage at this point to 2 V through the VR3 potentiometer. Calibration is completed.