

DISSOLVED OXYGEN SENSOR (WATER QUALITY ANALYSIS)

User Manual for SRWQ100-DO103-8901

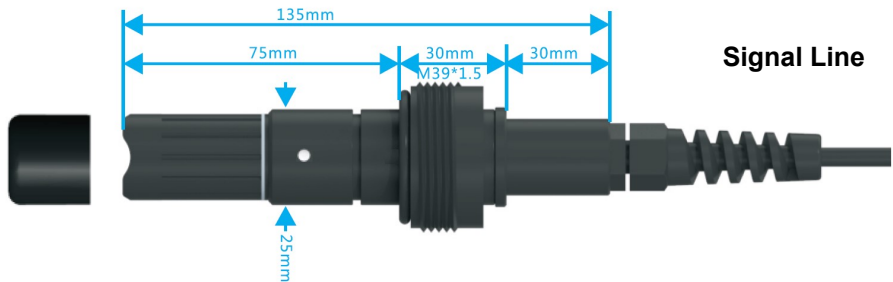

Thank you for choosing L-com product. To ensure safe, accurate performance and product longevity, please take a moment to familiarize yourself with this manual before powering the device. Please keep it handy for future reference. In case of any questions regarding the installation or use of product, please call us at 800.341.5266.

Reach out to us at customerservice@l-com.com and visit our website at www.l-com.com

Technical Indicators >>

Measuring Range	0.00 – 20.00 mg/L
Resolution	0.01 mg/L
Accuracy	±0.2% FS
Temperature Range	0 – 60.0 °C
Resolution	0.1 °C
Accuracy	±0.2 °C
Pressure Range	0 – 2 bar
Medium Flow Rate	15 – 30 L/h
Shell Material	ABS, 316 L
Output	RS485, 4 – 20 mA
Power Supply	9 – 30 VDC (Recommend 12V)
Pipe Thread	M 39*1.5
Cable Length	5m or customized
Sensitivity	±0.05% of range
Protection Grade	IP68

Instructions Before Use >>

- The membrane head is fragile, it cannot be repaired in case of damage.
- Before using the electrode, gently remove the protective cover. Put electrode in the solution to test for polarization for more than 6 hours. For more details, refer Polarization Section.
- If no electrolyte is in the membrane, the measurement will be inaccurate or fluctuating.
- After adding membrane head with electrolyte, do not store the electrode in air for more than 30 mins.
- Clean and calibrate the membrane head timely. Presence of dirt, adhesive or encrust on the membrane head can cause inaccuracy in measurement.
- Make sure no bubbles are present in membrane head for accurate results.
- Extension, cutting, joint and forcefully pulling signal line may cause inaccurate results.

Electrode Wiring >>

- Please follow the instructions carefully, wrong wiring will damage the product completely.
- Examine all the wiring carefully in the system. Make sure wiring is complete before switching ON the power.
- It is strictly forbidden that RS485A line and RS485B line should not touch the power line. It will permanently damage the communication of the electrode.

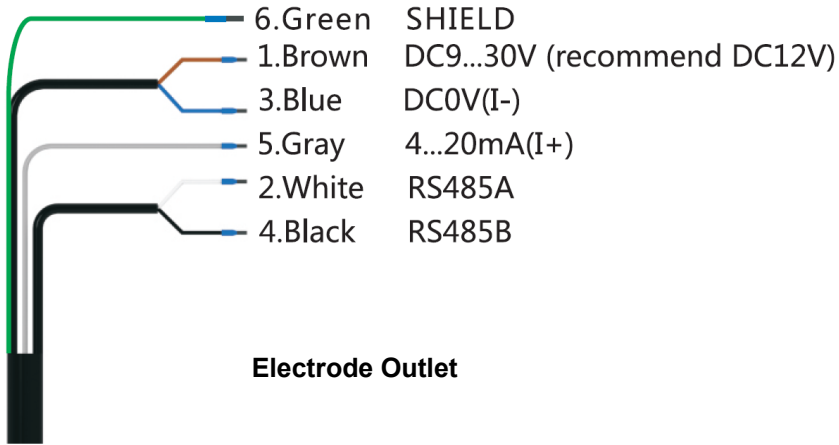

Procedure to Add Electrolyte and Replace the Membrane Head >>

- Kindly check the new membrane head is added with electrolyte before use.
- It is recommended to replace the electrolyte every three months. Also, it is subjected to the specific use of the measured medium and electrode.
- If the electrode signal is abnormal (long response time, mechanical damage, too large in zero oxygen water, too large or too small in air etc), the membrane head needs to be replaced. The normal oxygen membrane is replaced every 6 to 12 months, and the toughened oxygen membrane is replaced every 18 to 24 months.
- Follow the below procedure to replace the membrane head and add electrolyte:

<p>Disconnect the power supply. Turn the membrane head counter-clockwise. Remove the membrane head smoothly. Pour the residual electrolyte inside the membrane head to the waste solution pool.</p>	<p>Tilt the membrane head and the electrolyte bottle is vertically downward. Gently squeeze the electrolyte bottle, so that the electrolyte slowly fills into the membrane head until it is full.</p>	<p>Slowly turn the membrane head clockwise onto the inner core of the electrode until the liquid beads flow out. Tighten and loosen the membrane head 3 times to completely burst the bubbles and make the membrane head close to the electrode cathode.</p>

Electrode Polarization >>

Polarization Method: Put the electrode in the solution to be tested. Connect the power supply. Polarization starts as soon as the power is turned ON.

Polarization Cases: The electrodes needs to be polarized in the following cases:

- When the electrode is first used, polarize it for more than 6 hours.
- When the membrane head or electrolyte is replaced, polarize it for more than 6 hours.
- If electrode is disconnected from the power line. See the below table for polarization time:

Power OFF Time t1 (Minute)	Minimum Polarization Time t2 (Minute)
$t1 \leq 5$	$2 * t1$
$5 < t1 \leq 15$	$4 * t1$
$15 < t1 \leq 30$	$6 * t1$
$t1 > 30$	360

Electrode Calibration >>

- The electrode has been calibrated before shipment, user can directly use it. Online monitoring of the measured medium should keep a constant flow rate, range 15 - 30 L/h.
- The calibration of dissolved oxygen electrode is performed by zero oxygen calibration and full scale calibration, Before the calibration, ensure that the cable is connected to the instrument and the electrode has polarized for more than 6 hours.
- Users are recommended to calibrate the electrode every 1 to 2 months.

Electrode Installation >>

It is recommended DO Electrode to be installed in the flow cell for more stable and accurate measurement. If electrode is installed in the pipe, the right angle should be 15° - 165° .

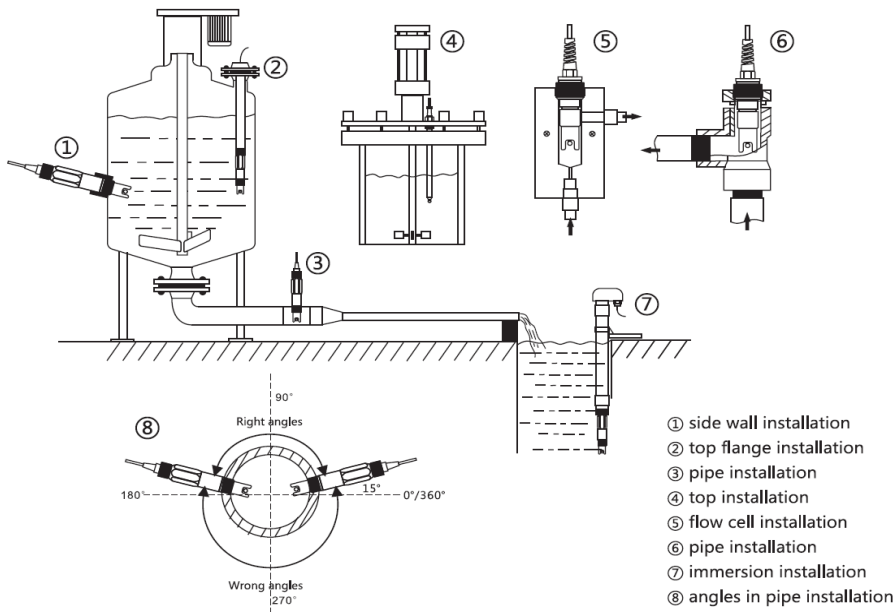

During Immersion Installation >>

- During installation procedure, there will be frequent dirt on electrode, clean it regularly.
- Measuring value is not stable.
- Different insertion depths affects the measured value.
- The position of the electrode must be above the sediment.

Electrode Communication >>

Default Communication Instructions:

- Data starting at 0x represents hexadecimal.
- The check code is 16CRC, the low byte is in the front and the high byte is in the back.
- Floating point number occupy four bytes.

Communication Description (Factory Default):

Baud Rate	9600 (Default)
Data Bit	8
Stop Bit	1
Check Bit	No
Address	1 (Default)

Host Computer Transmission Format:

	Data Type	Description	Remarks
Integer	16-Bit Integer	The high-low bytes of word component are not reversed	Ex: 0 x 0032 to decimal number is 50
Floating Point Number	(CDAB) 3412	The high-low word of the double-byte component is reversed, but the high-low byte of the word is not reversed.	Example: 72 37 41 DB transfer to floating point number. CDAB change order is ABCD. Eg: 41 DB 72 37 transfer to floating point is 27.4

Function Code Description:

- This product supports 03,06,16 and other common function codes.
- The output register uses 16 function codes when writing double word data or writing multiple data in batches.

03	Read single or multiple registers
06	Write single register
16	Write multiple registers

Read Floating Point Number >>

Host Computer Transmission Format:

	ID Address	Function Code	Register Start Address		Qty. Of Registers		CRC16	
			High Byte	Low Byte	High Byte	Low Byte	High Byte	Low Byte
Eg: Read Measured Value	0x01	0x03	0x00	0x01	0x00	0x02	0xCB	0x95
Eg: Read Temp. Value	0x01	0x03	0x00	0x03	0x00	0x02	0x0B	0x34

Slave Computer Response Format:

	ID Address	Function Code	Qty of Registers	Read Register Data in Hexadecimal Floating Point Number				CRC16	
				C	D	A	B	High Byte	Low Byte
Eg: Measured Value Return	0x01	0x03	0x04	0x2C	0x81	0x40	0x91	0xE7	0x52
Eg: Temp. Value Return	0x01	0x03	0x04	0x72	0x37	0x41	0xDB	0x8E	0x20

Note: 72 37 41 DB transfer to floating point number, CDAB change order is ABCD, i.e. 41 DB 72 37 transfer to floating point is 27.4.

Read Integer >>

Host Computer Transmission Format:

	ID Address	Function Code	Register Start Address		Qty. Of Registers		CRC16	
			High Byte	Low Byte	High Byte	Low Byte	High Byte	Low Byte
Eg: Read Warning Status	0x01	0x03	0x00	0x07	0x00	0x01	0xCB	0x35

Slave Computer Response Format:

	ID Address	Function Code	Qty of Registers	Read Register Data in Hexadecimal Floating Point Number		CRC16	
				A	B	High Byte	Low Byte
Eg: Measured Value Return	0x01	0x03	0x02	0x00	0x00	0x44	0xB8

Write Floating Point Number >>

Host Computer Transmission Format:

	ID	Function Code	Register Start Address		Qty. Of Registers		Qty Of Byte	Register Data in Hexadecimal Floating Point Number				CRC16	
			High Byte	Low Byte	High Byte	Low Byte		C	D	A	B	High Byte	Low Byte
Eg: Write Value Offset	0x01	0x10	0x00	0x12	0x00	0x02	0x04	0x00	0x00	0x3F	0x80	0x2A	0x63

Slave Computer Response Format:

	ID Address	Function Code	Register Start Address		Qty. Of Registers		CRC16	
			High Byte	Low Byte	High Byte	Low Byte	High Byte	Low Byte
Eg: Return Value Offset	0x01	0x13	0x00	0x12	0x00	0x02	0xCD	0xE1

Note: The measured value if offset by 1.00, floating point number 1.00 converts to hexadecimal 0X3F800000, transpose the high and low positions 0X00003F80 and write 0X0012.

Write Integer >>

Host Computer Transmission Format:

	ID Address	Function Code	Register Start Address		Register Data in Hexadecimal Integer		CRC16	
			High Byte	Low Byte	A	B	High Byte	Low Byte
Eg: Write Device Address	0x01	0x06	0x00	0x19	0x00	0x02	0xCC	0xD9

Slave Computer Response Format:

	ID Address	Function Code	Register Start Address		Register Data in Hexadecimal Integer		CRC16	
			High Byte	Low Byte	A	B	High Byte	Low Byte
Eg: Device Return Address	0x01	0x06	0x00	0x19	0x00	0x02	0xCC	0xD9

Note: Change the local computer address 1 to address 2 and write the hexadecimal number 0X00 02 into register 0X00 19.

Calibration Instructions >>

The First Point: Zero Calibration:

- The sensor is cleaned, dried and put in a 0 mg/L solution (i.e., anhydrous sodium sulfite solution)
- Send command: 01 03 00 66 00 01 64 15
- After the measured AD value is stable, read the AD value in the Ox66 register.
- Write the instruction to confirm the calibration to the Ox 3E register
- Send command: 01 06 00 3E 00 FF A8 46.

The Second Point: Slope Calibration:

- The sensor is cleaned and dried and put in saturated air (i.e., 100%).
- Send command: 01 03 00 66 00 01 64 15
- After the measured AD value is stable, read the AD value in the Ox66 register.
- Write the instruction to confirm the calibration to the Ox 3F register
- Send command: 01 06 00 3F 00 FF F9 86
- This product can be calibrated at 1 point or 2 points.
- If the first point is not calibrated, directly calibrate the second point.

Address Description >>

Name	Hosting Number	Data Type	Length	Read/Write	Description
Measurements	0x 00 01	Floating Point	2	Read	Storage location for measured value
Temperature Measurement	0x 00 03	Floating Point	2	Read	Storage location for measured temperature
Current Output Value	0x 00 05	Floating Point	2	Read	Output current based on DO measurements
Warning	0x 00 07	Integer	1	Read	01: Measurement exceeds the upper limit; 02: Measurement exceeds the lower limit; 03: Temperature exceeds the upper limit; 04: Temperature exceeds the lower limit
Measurement Mode	0x 00 08	Integer	1	Read/Write	00:% 01: mg/L

Name	Hosting Number	Data Type	Length	Read/Write	Description
Measurements	0x 00 01	Floating Point	2	Read	Storage location for measured value
Upper Limit Of Measurement	0x 00 0A	Floating Point	2	Read/Write	Default value 200%, Upper limit of measured value (20mA corresponding value)
Lower Limit Of Measurement	0x 00 0C	Floating Point	2	Read/Write	Default value 0, Lower limit of measurement value (4mA corresponding value)
Upper Temperature Limit	0x 00 0E	Floating Point	2	Read/Write	Default value 60°C, Upper temperature limit
Lower Temperature Limit	0x 00 10	Floating Point	2	Read/Write	Default value 0°C, Lower temperature limit
Measured Value Offset	0x 00 12	Floating Point	2	Read/Write	Default value 0, Adjust measurement
Temperature Offset	0x 00 14	Floating Point	2	Read/Write	Default value 0, Adjust temperature value
Damping Coefficient	0x 00 16	Integer	1	Read/Write	Default value 0, 0-10
Device Address	0x 00 19	Integer	1	Read/Write	Default value 01; 1-255
Baud Rate	0x 00 1A	Integer	1	Read/Write	Default value 9600; 0=2400 , 1=4800, 2=9600, 3=19200, 4=38400
Restore Default	0x 00 1B	Integer	1	Write	
Pressure Compensation	0x 00 30	Floating Point	2	Read/Write	1013 mbar
Salinity Compensation	0x 00 24	Floating Point	2	Read/Write	0.0 ppt
Calibration Slope	0x 00 2C	Integer	2	Read	-0.1984
Manual Temperature	0x 00 3A	Floating Point	2	Read/Write	25°C
Zero Calibration	0x 00 3E	Integer	1	Write	
Slope Calibration	0x 00 3F	Integer	1	Write	
Measuring AD	0x 00 66	Integer	1	Read	

Common Instruction Examples >>

Sr. No.	Function	Send command	Return command	Remarks
1	Read measured value	01 03 00 01 00 02 95 CB	01 03 04 2C 81 40 91 52 E7	The 2C814091 change order is 40912C81 and its floating point is 4.53
2	Read temperature measurement	01 03 00 03 00 02 34 0B	01 03 04 72 37 41 DB 20 8E	The 723741DB change order is 41DB7237 and its floating point is 27.4
3	Read current output value	01 03 00 05 00 02 D4 0A	01 03 04 00 00 41 40 CB 93	The 00004140 change order is 41400000 and its floating point is 12.00
4	Read warning	01 03 00 07 00 01 35 CB	01 03 02 00 00 B8 44	0000 is the current state
5	Write measurement mode	01 06 00 08 00 01 C9 C8	01 06 00 08 00 01 C9 C8	Set to mg/L mode
6	Write upper limit of measurement	01 10 00 0A 00 02 04 00 00 41 20 42 58	01 10 00 0A 00 02 61 CA	The upper measurement limit is set to 10.00
7	Write lower limit of measurement	01 10 00 0C 00 02 04 00 00 3F 80 E3 AA	01 10 00 0C 00 02 81 CB	The lower measurement limit is set to 1.00
8	Write upper temperature limit	01 10 00 0E 00 02 04 00 00 42 C8 43 15	01 10 00 0E 00 02 20 0B	The upper temperature limit is set to 100.00
9	Write lower temperature limit	01 10 00 10 00 02 04 00 00 40 A0 C3 1B	01 10 00 10 00 02 40 0D	The lower temperature limit is set to 5.00
10	Write measured value offset	01 10 00 12 00 02 04 00 00 3F 80 63 2A	01 10 00 12 00 02 E1 CD	Set to 1.00
11	Write temperature offset	01 10 00 14 00 02 04 00 00 3F 80 E3 00	01 10 00 14 00 02 01 CC	Set to 1.00
12	Write damping coefficient	01 06 00 16 00 01 A9 CE	01 06 00 16 00 01 A9 CE	Set to 1
13	Write device address	01 06 00 19 00 02 D9 CC	01 06 00 19 00 02 D9 CC	Set to 2
14	Write baud rate	01 06 00 1A 00 00 A8 0D	01 06 00 1A 00 00 A8 0D	Set to 2400
15	Write restore default	01 06 00 1B 00 FF B9 8D	01 06 00 1B 00 FF B9 8D	Factory default values are restored after sent

Sr. No.	Function	Send command	Return command	Remarks
16	Write pressure compensation	01 10 00 2C 00 02 04 00 00 44 7A 43 01	01 10 00 2C 00 02 80 01	Pressure compensation written to 1000 mbar
17	Read calibration slope	01 03 00 22 00 02 64 01	01 03 04 CC CD 3E 4C 45 09	The CCD3E4C order is 3E4CCCD and its floating point is 0.2
18	Write salinity compensation	01 10 00 24 00 02 04 CC CD 3E 4C 4F 7E	01 10 00 24 00 02 01 C3	Salinity compensation written to 0.2ppt
19	Write manual temperature	01 10 00 3A 00 02 04 00 00 41 A0 40 EC	01 10 00 3A 00 02 61 C5	Set to 20.0
20	Write zero calibration	01 06 00 3E 00 FF A8 46	01 06 00 3E 00 FF A8 46	Confirm calibration zero
21	Write slope calibration	01 06 00 3F 00 FF F9 86	01 06 00 3F 00 FF F9 86	Confirm calibration slope
22	Read measuring AD	01 03 00 66 00 01 64 15	01 03 02 2E E0 A4 6C	2EE0 turns to integer 12000

Maintenance And Storage >>

- The electrode should be cleaned regularly with deionized water.
- Be careful while disassembling and rinsing the electrode, the oxygen-permeable membrane should not brake.
- Do not wipe oxygen-permeable membrane on the electrode with filter paper or sandpaper.
- If the membrane head is fouled and clogged, the electrolyte is dry, lack or is contaminated. Stop using the membrane and its head should be removed and cleaned.
- After cleaning the electrode, replace the membrane head, add electrolyte. After long-term storage, it needs to be polarized and calibrated before use.
- The cable connector must be kept clean, dry, free from moisture, water, acids, alkalis or salts, etc.
- If water supply is cut off or electrode is not used on site, the electrode should be taken out, cleaned and covered with protective sleeve containing water for preservation.
- If the electrode is not used and stored for a long time, remove the electrode, disconnect the cable, drain the electrolyte, thoroughly clean the anode and the cathode with deionized water at 30 °C-40 °C, dry it and put on the protective cover. Place it in a dry place for storage.

Troubleshooting >>

- If the measurement is not accurate, its mostly because the condition of dissolved oxygen electrode has changed. So it is necessary to check whether the dissolved oxygen electrode is in good condition or not.
- The dissolved oxygen electrode is not easy to damage, generally the membrane head may has dirt ,the electrolyte maybe polluted or lost etc., user needs to replace the membrane head or add / change electrolyte.
- If the value of the instrument is too large, too small or no change, check whether the electrolyte is dry, missing or contaminated. If the above conditions occur, change / add the electrolyte.

MODBUS Troubleshooting >>

Problem	Possible reason	Solution
Modbus no response	The baud rate, or stop bit does not match the Modbus master settings	Verify that the settings match the Modbus master device settings, and verify that the Modbus master device parity check is set to None.
	Rs232 or RS485 cable is faulty	Replace / repair cables
	No network offsets and terminations, or network offsets and terminations are not suitable.	Check the termination or offset settings for all network devices. Only the endpoints of the network should be turned on and terminated, and there should be only a point on the network to provide an offset.
	The slave address is incorrect, or the slave address is the same as the address of another bus device	Verify that all addresses are unique and are between 1 and 247.
Modbus abnormal response	Register not supported	Verify that the register is supported.
	Incorrect data type	Verify that the requested register data type matches the Modbus master device request. For example, user cannot access a floating point data using 2-byte integer data. When a floating point data (2 registers / 4 bytes) is requested, two registers must be requested at the same time.