

THE INFORMATION CONTAINED IN THIS DRAWING IS THE SOLE PROPERTY OF L-COM, INC. ANY REPRODUCTION IN PART OR WHOLE WITHOUT THE WRITTEN PERMISSION OF L-COM, INC. IS PROHIBITED.

| REVISIONS |                 |          |           |
|-----------|-----------------|----------|-----------|
| REV       | DESCRIPTION     | DATE     | APPROVED  |
| A         | INITIAL RELEASE | 10/28/15 | D.GRIFFIN |
|           |                 |          |           |
|           |                 |          |           |

| DESCRIPTION            | MATERIAL        | FINISH  |
|------------------------|-----------------|---------|
| BODY                   | BRASS           | CuSnZn3 |
| INNER CONDUCTOR FEMALE | PHOSPHOR BRONZE | SILVER  |
| INNER CONDUCTOR MALE   | BRASS           | SILVER  |
| COUPLING NUT           | BRASS           | CuSnZn3 |
| INSULATOR              | PTFE            | ---     |
| O-RING                 | SILICONE RUBBER | ---     |

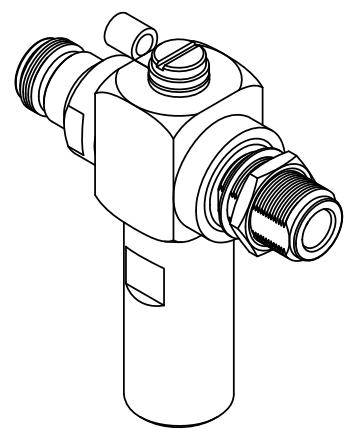
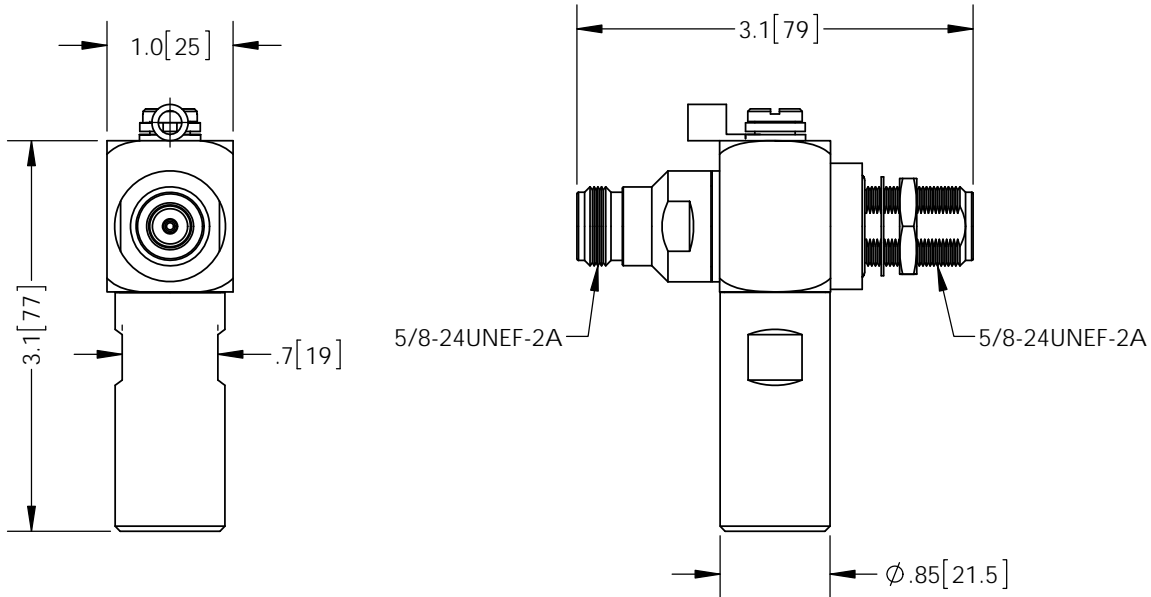

**NOTES:**  
**ELECTRICAL:**  
 IMPEDANCE: 50 OHM  
 FREQUENCY RANGE: 800 ~ 2,250 MHz  
 VSWR: ≤ 1.2  
 PASSIVE INTERMODULATION(PIM): ≤ -150dBc  
 DIELECTRIC WITHSTANDING VOLTAGE: 2500V (RMS)  
 INSULATION RESISTANCE: ≥ 5000M OHM  
**CONTACT RESISTANCE:**  
 CENTER CONTACT: ≤ 1.0m OHM  
 OUTER CONTACT: ≤ 1.0m OHM  
 INSERTION LOSS: ≤ 0.2dB

**MECHANICAL:**  
 DURABILITY: ≥ 500  
 TEMPERATURE RANGE: -40°C TO +85°C

**PACKAGING:**  
 COMPONENT SHALL BE INDIVIDUALLY PACKAGED IN ACCORDANCE WITH L-COM SPECIFICATION PKG-00012

**REGULATORY COMPLIANCE:**  
 CE2011/65/EU(RoHS DIRECTIVE)

|  |  |                  |                             |  |                  |
|--|--|------------------|-----------------------------|--|------------------|
| UNLESS OTHERWISE SPECIFIED, DIMENSIONS ARE IN INCHES [mm]<br><br>DIMENSIONAL TOLERANCES:<br>.X = ±.1 [2.54]<br>.XX = ±.01 [25]<br>.XXX = ±.005 [13]<br><br>ANGULAR TOLERANCES:<br>ALL = ± 1°<br><br>PROJECTION<br> | APPROVALS  | DATE             |                             | 45 BEECHWOOD DRIVE<br>NORTH ANDOVER, MA<br>01845               |                  |
|  | DRAWN BY<br>B.PUCHASKI                                   | 09/30/15         |                             |  |                  |
|  | CHECKED BY<br>K.BURGNER                                  | 09/30/15         | CATEGORY                    | LIGHTNING PROTECTOR  |                  |
|  | APPROVED BY<br>P.PESA                                    | 09/30/15         | PRODUCT DESCRIPTION         | N-FEMALE TO N-FEMALE BULKHEAD<br>PIM RATED LIGHTNING PROTECTOR |                  |
|  | CONFIGURATION DETAILS OF UNDIMENSIONED FEATURES MAY VARY | SIZE<br><b>A</b> | FSCM NO.<br><b>43321</b>    | DWG. NO.<br><b>ALQP-NFNFB</b>                                  | REV.<br><b>A</b> |
|  | COLOR VARIATIONS MAY OCCUR                               | SCALE: NONE      | CAD FILE: ALOP-NFNFB.SLDDRW | SHEET 1 OF 1   |                  |